



TemBreak

The Ultimate Safety Breaker

OUR CUSTOMER CARE COMMITMENTS

Quality is Guaranteed

All products supplied from this catalogue carry a guarantee against defects in materials and workmanship for a period of 12 months from date of purchase as standard.

Quality is Accredited

Terasaki has ISO 9001 accreditation for the manufacture, sale and distribution of all products featured in this catalogue.

Ordering is Easy

We have made ordering easy for you by colour coding the sections of this catalogue and including order codes. If you need help with ordering or selection, please call one of the telephone numbers shown below.

Technical Support is Free

We offer free technical support and application software to all customers. This could range from selecting a product for an unusual application through to carrying out a protection study. Please call one of the telephone numbers shown below.



CUSTOMER SERVICE CONTACT DETAILS

Italy:	+39 02 92278300	Australia and New Zealand:	+61 3 9429 2999
Spain & Latin America:	+34 93 8796050	Brazil:	+55 21 33019898
Sweden:	+46 8 55628230	Malaysia:	+60 3 55493820
Denmark:	+45 70 260057	Singapore:	+65 6425 4915
UK and all other countries in Europe, Middle East and Africa:	+44 141 9411940	China:	+86 20 8270 8556
		Japan and all other countries in Asia:	+81 6 67919323

Safety and protection are the prime purposes of Terasaki products. You care about safety and protection. The users of products you specify care about safety and protection.

We call TemBreak 2 the Ultimate Safety Breaker. Throughout this catalogue you will see our Safety+ mark. This is designed to draw your attention to safety features which exceed international standards.

Please read further to discover the benefits of TemBreak 2.



THE TEMBREAK 2 PRODUCT LINES

TEMBREAK 2

MOULDED CASE CIRCUIT BREAKERS

Rated current (I_n) from 20A to 1600A. Breaking Capacity (I_{cu}) from 25kA to 200kA at 415V AC.

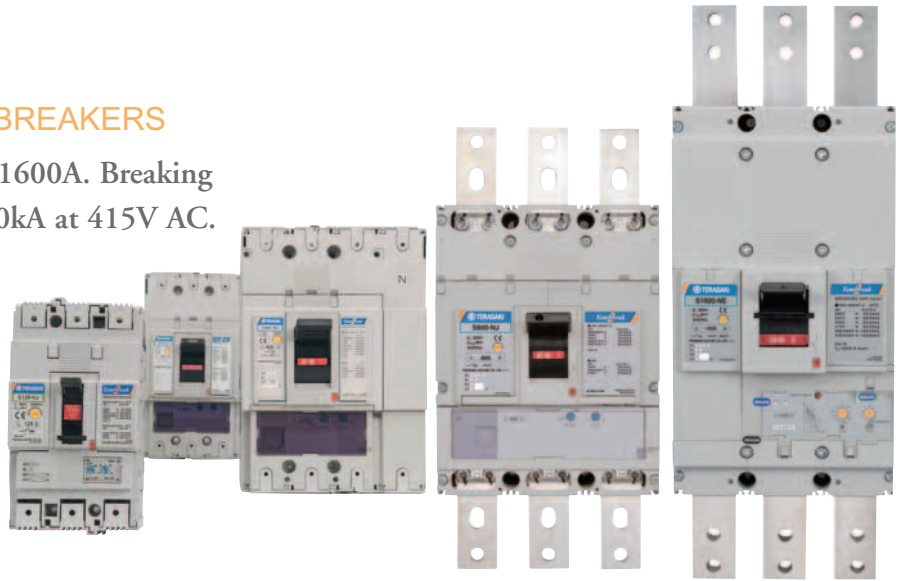

TEMBREAK 2 MOULDED CASE CIRCUIT BREAKERS 16A TO 1600A

1. Welcome to TemBreak 2	
• Easy Selection Guide	5
• 10 Reasons to use TemBreak 2	7
• Safety Plus	9
• Exceeding Standards	11
• Reducing Environmental Impact	12
2. Ratings and Specifications	
3. Operating Characteristics	
4. Application Data	
5. Accessories	
6. Installation	
7. Dimensions	

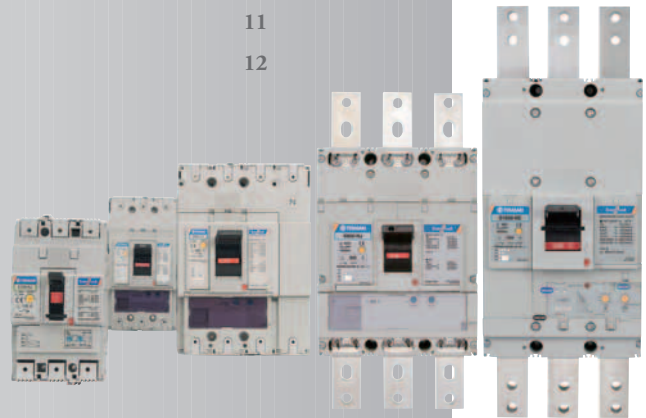

WELCOME TO TEMBREAK 2

EASY SELECTION GUIDE

The TemBreak 2 range of products includes:

- Moulded Case Circuit Breakers (MCCBs)
- Switch-Disconnectors in the same compact moulded case frame sizes as MCCBs
- A comprehensive range of accessories which are common to MCCBs and Switch-Disconnectors. All internal accessories are common to all frame sizes.



Key to Model and Type Designations

Model Denoted by

Type Denoted by

E	Economical
S	Standard
H	High
L	Limiting*

C,S	Low breaking capacity
N	Medium breaking capacity
G,R	High breaking capacity
P	Extra High breaking capacity

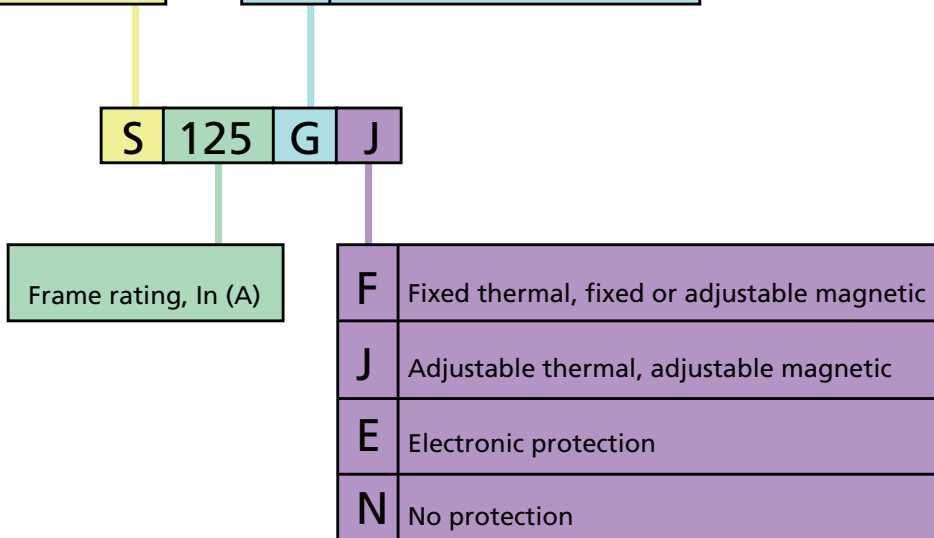

EASY SELECTION GUIDE

 <p>Frame Rating (A)</p> <p>125</p>	 <p>160/250</p>	 <p>400/630</p>	 <p>800/1000</p>	 <p>1250/1600</p>
--	---	---	--	---

MCCBs

	Model	Type	I_{cu} (kA)	Model	Type	I_{cu} (kA)	Model	Type	I_{cu} (kA)	Model	Type	I_{cu} (kA)	Model	Type	I_{cu} (kA)
E	E125	NJ	25	E250	NJ	25	E400	NJ	25						
							E630	NE	36						
S	S125	NF	25	S160	NF	25	S400	CJ	36	S800	CJ	36	S1250	SE	50
	S125	NJ	36	S160	NJ	36	S400	NJ	50	S800	NJ	50	S1250	NE	70
	S125	GJ	65	S160	GJ	65	S400	NE	50	S800	NE	50	S1250	GE	85
				S250	NJ	36	S400	GJ	70	S800	RJ	70	S1600	SE	50
				S250	NE	36	S400	GE	70	S800	RE	70	S1600	NE	85
				S250	GJ	65	S400	PJ	85	S1000	SE	50			
				S250	GE	65	S400	PE	85	S1000	NE	70			
				S250	PE	70	S630	CE	50						
							S630	GE	70						
H	H125*	NJ	125	H160	NJ	125	H400	NE	125	H800	NE	125			
				H250	NJ	125									
				H250	NE	125									
L	L125*	NJ	200	L160	NJ	200	L400	NE	200	L800	NE	200			
				L250	NJ	200									

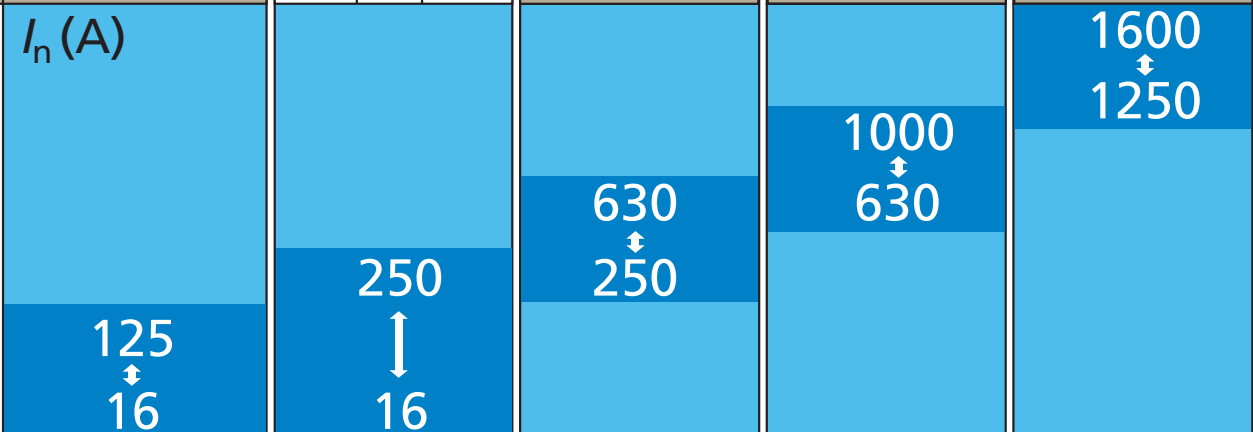

Switch-Disconnectors

Model	Type	Model	Type	Model	Type	Model	Type	Model	Type
S125	NN	S160	NN	S400	NN	S800	NN	S1250	NN
		S250	NN	S630	NN	S1000	NN	S1600	NN

Note: All breaking capacities are r.m.s. symmetrical at 415V AC

*250A Frame

10 REASONS TO USE TEMBREAK 2

1. FIELD-INSTALLABLE ACCESSORIES

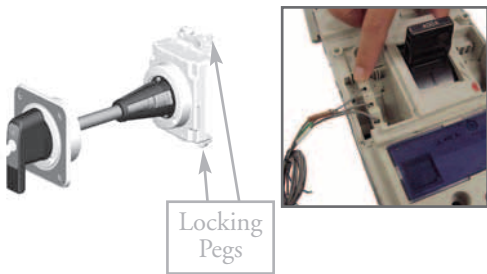

- Accessories can be fitted by the switchboard builder or added by the end-user.
- Handles and motor operators can be rapidly fitted using the locking pegs. It takes **less than 10 seconds to secure a handle or motor to the MCCB** – a great time saving compared to alternative products.
- All accessories are endurance tested to the same level as the host MCCB.

2. SAFETY LOCK FOR PLUG-IN VERSIONS

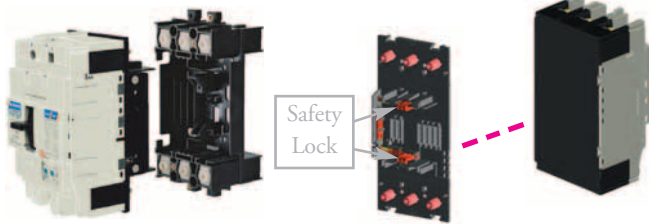

Plug-in MCCB and base

Plug-in connection kit, including safety lock

The plug-in MCCB is locked to the base when the toggle is ON. It cannot be removed unless the toggle is OFF or TRIPPED. The safety lock prevents a trip occurring as the MCCB is being removed from the base.

3. SYMMETRICAL DOOR CUTOUT PATTERNS

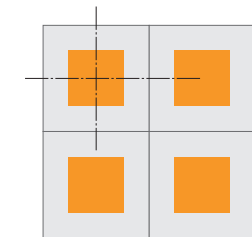

Using TemBreak 2 Operating Handles

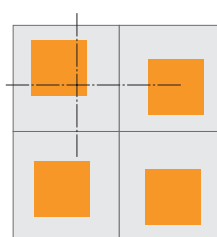

Using other MCCB Operating Handles

Door cutout patterns for handles are symmetrical, even when breakers are mounted in opposite directions.

4. MODULAR SIZES



All current ratings up to 630A can be supplied in 2 sizes: the 250A and 630A sizes.



The compact 125A size offers the same features and performance but with reduced dimensions and cost.

5. ADVANCED L.C.D. DISPLAY, OCR



The XOW-1S OCR comes standard with the backlit LCD display. It can monitor and indicate phase currents, voltages, power, energy, power factor, harmonic currents, and more. Data communications via Modbus, an open network, are supported.

10 REASONS TO USE TEMBREAK 2

6. COMPACT CHANGEOVERS



Changeover Pair with Link Interlock and Motor Operators

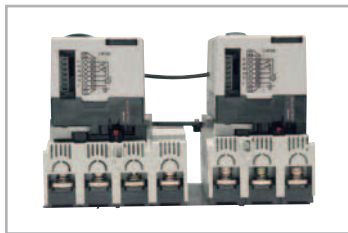

Viewed from Below (250A frame)

The mechanical interlock is installed on the front of the MCCB, and is compatible with motor operators and handles. An automatic changeover system can be assembled very easily by a switchboard builder or end-user.

7. DIRECT OPENING



Under the heading “Measures to minimise the risk in the event of failure”, IEC 60204-1 Safety of Machinery-Electrical Equipment of Machinery includes the following recommendation:

“-the use of switching devices having positive (or direct) opening operation.”

8. UNSURPASSED FLEXIBILITY

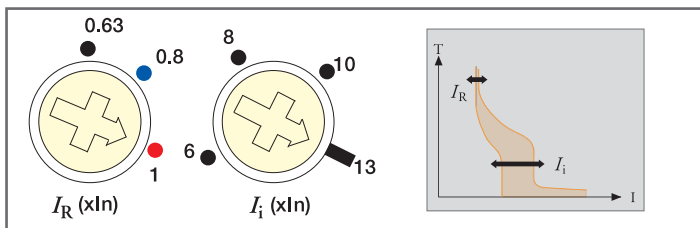

Overload protection is adjustable between 63% and 100% of the rating.

Short-circuit protection is adjustable on all thermal magnetic models.

Short-circuit protection settings are suitable for motor starting on all models, including the compact 125A frame.

9. CUSTOMISED TRIPPING TIMES

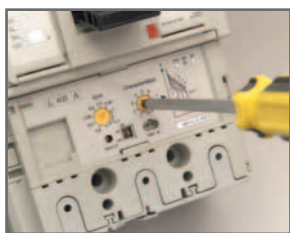

If you require a characteristic which is not available as a preset on our electronic protection unit, send us the details and we will program a customised characteristic to suit your application. (Within certain limits - contact us for details).

10. VISUAL SAFETY

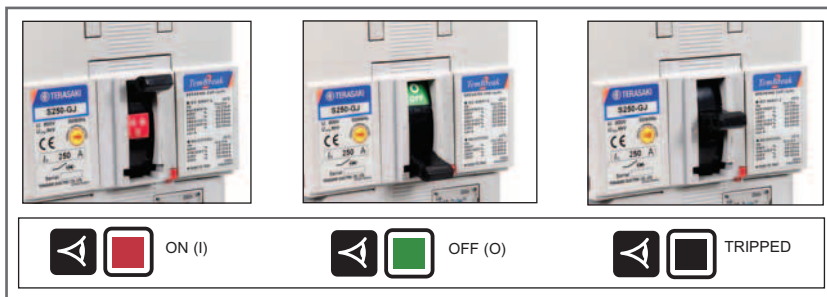

Coloured indicators display the ON or OFF status. The indicators are fully covered if the breaker trips, and black is the only visible colour.



WELCOME TO TEMBREAK 2

SAFETY PLUS

Terasaki have an innovative approach to product design. Our goal is to develop products which not only meet, but exceed recognised standards.

We use our knowledge of related applications to improve circuit breaker designs. For instance, when developing the Direct Opening Action, we applied ideas from a machinery safety standard to the design of the TemBreak 2 switching mechanism.

This proactive development policy confirms our reputation as Innovators in Protection Technology.



Machine Safety

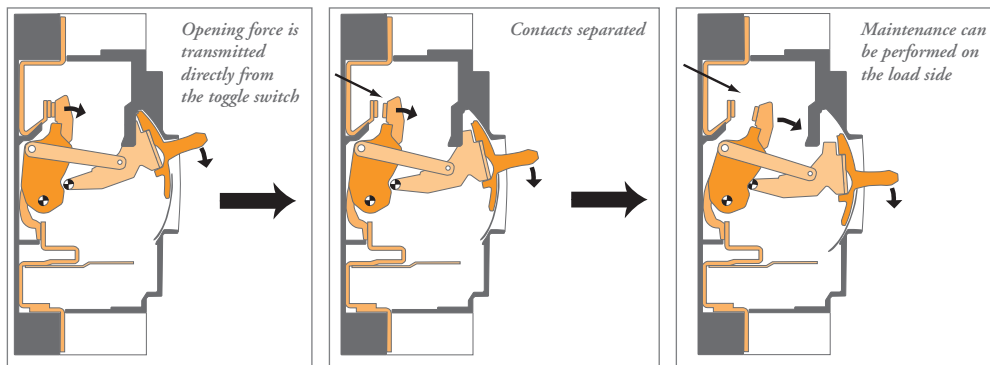

TemBreak 2 MCCBs are marked with IEC symbol indicating Direct Opening Action. (→)

The robust mechanism ensures that the force you apply to the toggle is transmitted directly to the contacts.

Under the heading “Measures to minimise risk in the event of failure”, IEC 60204-1 Safety of Machinery - Electrical Equipment of Machines includes the following recommendation:

“ - the use of switching devices having positive (or direct) opening operation.”

TemBreak 2 MCCBs help you to comply with the world’s most stringent safety standards. It is one of the safest switching devices for machinery.

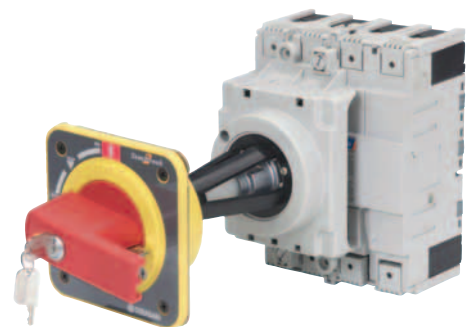

WELCOME TO TEMBREAK 2

SAFETY PLUS

Visual Safety

You can easily see if a breaker is open, closed or tripped. **SAFETY+** coloured indicators boldly display the ON or OFF status. The indicators are fully covered if a breaker trips, and black is the only visible colour.

This is a *unique* safety feature. You can identify faulty circuits at a glance.

The toggle position always matches the position of the main contacts.

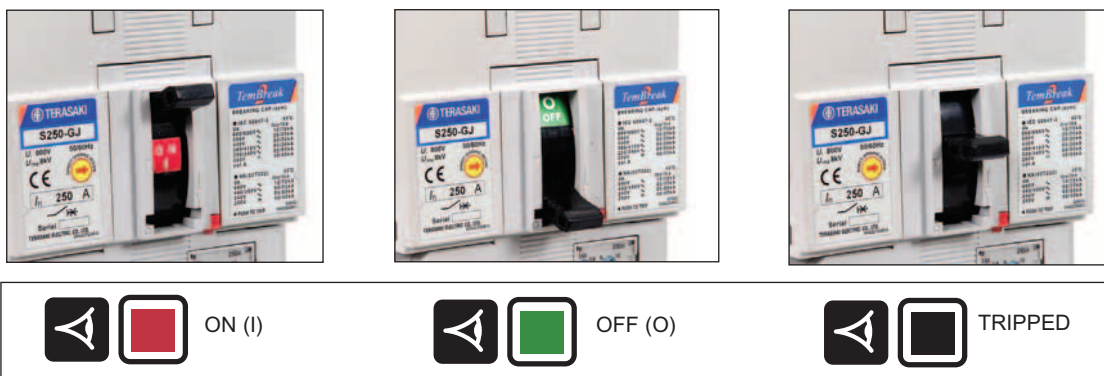

Touch Safety

The risk of touching live parts has been minimised by design. These features reduce the risk of touching live parts:

- There are no exposed metal screws on the front face
- IP20 protection at the terminals
- IP30 protection at the toggle
- If the toggle is broken by accident or misuse, no live part is exposed
- No live parts are exposed when fitting accessories
- Double Insulation

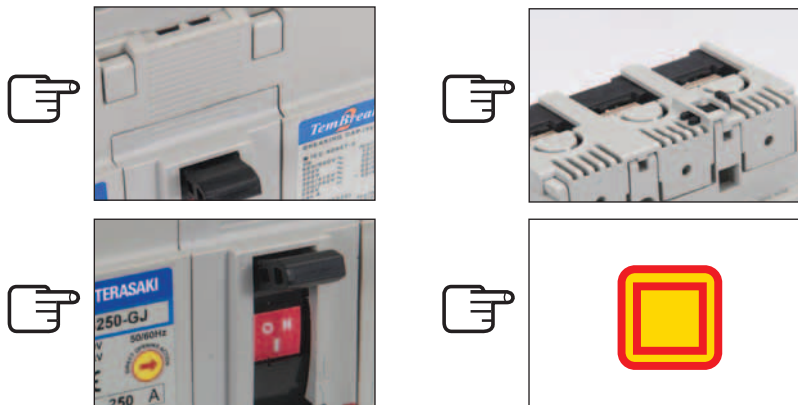

WELCOME TO TEMBREAK 2

EXCEEDING STANDARDS

Safety Plus

TemBreak 2 MCCBs exceed the requirements of recognised standards.

International Compliance

- The TemBreak 2 MCCB complies with the international standard IEC 60947-2
- TemBreak 2 Switch Disconnectors comply with IEC 60947-3
- Accessories comply with IEC 60947-5-1 or IEC 61058-1
- The entire range conforms to the IEC general rules for switchgear, IEC 60947-1
- TemBreak 2 MCCBs comply with JIS C 8201-2-1 Ann.1
- The TemBreak 2 range complies with the EC Low Voltage Directive and all models are CE marked
- TemBreak 2 MCCBs carry the IEC symbol indicating Direct Opening Action as defined by IEC 60947-5-1. IEC 60204-1, Safety of Machinery - Electrical Equipment of Machines recommends that switches used for machinery have Direct Opening Action to minimise risk in the event of failure



Independent Tests

TemBreak 2 circuit breakers have been tested at independent laboratories as well as in Terasaki's own laboratory in Osaka, Japan. Copies of independent test reports are available on request.

Marine Approvals

TemBreak 2 MCCBs are approved by the leading marine approval organisations.



WELCOME TO TEMBREAK 2

REDUCING ENVIRONMENTAL IMPACT

Longer Life Cycle

It makes good environmental sense to install a product with a long life expectancy. If you install a TemBreak 2 MCCB, you can expect it to stay in service for at least 30,000 mechanical operations (250A Frame). This is 22,000 more operations than recommended by IEC 60947-2, the international standard for circuit breakers.

If a system must be upgraded in future, we have made the following provisions for recycling:

- ① The modular design of TemBreak 2 allows component parts and accessories to be easily disassembled and separately disposed of. Moulded parts do not contain any embedded metal parts.
- ② Materials are clearly marked to allow future identification for easy recycling.

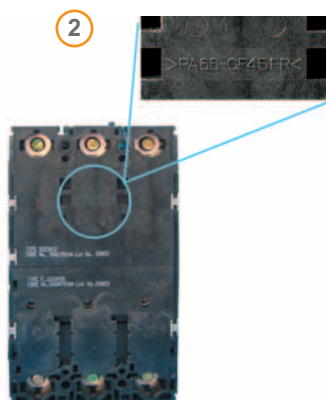
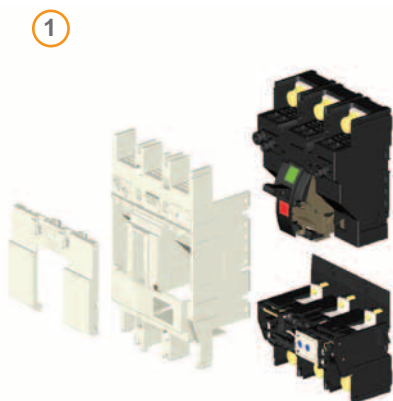

Uses Eco-friendly Materials

The following materials are used in most TemBreak 2 circuit breakers:

- Thermoplastic resin not containing PBBs or PBDEs
- Lead-free solder
- Cadmium-free contacts

Lighter and Smaller

Components with low weight and volume make life easy for users, but high performance from smaller products also means less material used and less waste produced.

ISO 14001

Terasaki operate an Environmental Management System accredited to ISO 14001:1999. This requires us to monitor and measure the environmental performance of our activities, products and services in order to continually improve such performance.

Further information about this standard can be found on the internet at: www.tc207.org

FIELD-INSTALLABLE ACCESSORIES

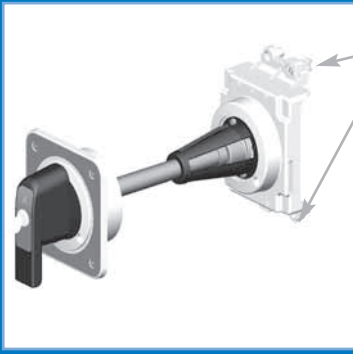

Locking
Pegs

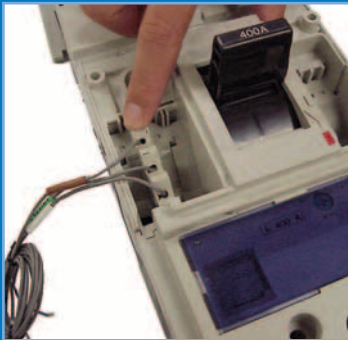

- Accessories can be fitted by the switchboard builder or added by the end-user. All internal accessories are common for TemBreak 2 MCCBs.
- Handles and motor operators can be rapidly fitted using the locking pegs. It takes less than 10 seconds to secure a handle or motor to the MCCB – a great time saving compared to alternative products.
- All accessories are endurance tested to the same level as the host MCCB.



RATINGS AND SPECIFICATIONS

TEMBREAK 2 MOULDED CASE CIRCUIT BREAKERS 16A TO 1600A

1. Welcome to TemBreak 2

2. Ratings and Specifications

- MCCBs 15
- Switch-Disconnectors 21

3. Operating Characteristics

4. Application Data

5. Accessories

6. Installation

7. Dimensions

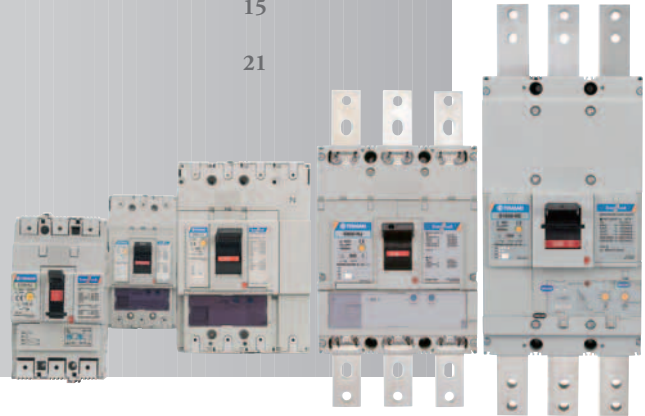

RATINGS AND SPECIFICATIONS

MCCB ELECTRICAL CHARACTERISTICS TO IEC 60947-2, EN 60947-2, JIS C 8201-2-1 ANN.1, AS/NZS 3947-2, NEMA AB-1

Frame	Quantity	Unit	Condition	125	
Model				E125	S125
Number of Poles				3, 4	1
Type				NJ	NF
Nominal current ratings					
	I_n	(A)	45°C	20,32,50, 63,100,125	16,20,25, 32,40,50, 63, 80, 100,125
Electrical characteristics					
Rated operational voltage	U_c	(V)	AC 50/60 Hz DC	525 250	240 -
Rated insulation voltage	U_i	(V)		800	800
Rated impulse withstand voltage	U_{imp}	(kV)		8	8
Ultimate breaking capacity (IEC, JIS, AS/NZS)	I_{cu}	(kA)	690V AC	-	-
			525V AC	8	-
			440V AC	15	-
			400/415V AC	25	-
			220/240V AC	35	25
			250V DC	25	-
Service breaking capacity (IEC, JIS, AS/NZS)	I_{cs}	(kA)	690V AC	-	-
			525V AC	6	-
			440V AC	12	-
			400/415V AC	19	-
			220/240V AC	27	13
			250V DC	19	-
Rated breaking capacity (NEMA)		(kA)	480V AC 240VAC	8 35	- 25
Protection					
Adjustable thermal, adjustable magnetic				■	
Fixed thermal, fixed magnetic					■
Microprocessor					
Utilisation category				A	A
Installation					
Front connection (FC)				■	■
Extension bar (FB)				•	•
Cable clamp (FW)				•	•
Rear connection (RC)				•	-
Plug-in (PM)				•	-
Draw- out (DR)				-	-
DIN rail mounting (DA)				•	•
Dimensions	h	(mm)		155	155
	w	(mm)	3 pole, (1 pole) 4 pole	90 120	(30)
	d	(mm)		68	68
Weight	W	(kg)	3 pole, (1 pole) 4 pole	1.1 1.4	(0.45)
Operation					
Direct Opening Action				■	■
Toggle operation				■	■
Door mounted (HS, HP) / Breaker mounted handle (HB)				•	-
Motor operation (MC)				•	-
Endurance	Electrical Mechanical	cycles cycles	440V AC	←	

RATINGS AND SPECIFICATIONS

					160				
	S125	S125	H125	L125	S160	S160	S160	H160	L160
	3, 4 NJ	3,4 GJ	3, 4 NJ	3, 4 NJ	1 NF	3, 4 NJ	3, 4 GJ	3, 4 NJ	3, 4 NJ
	20,32,50, 63,100,125	20,32,50, 63,100,125	20,32,50, 63,100,125	20,32,50, 63,100,125	16,20,25,32, 40,50,63,80, 100,125,160	20,32,50,63, 100,125,160	50,63,100, 125,160	160	160
	690 250 800 8	690 250 800 8	690 250 800 8	690 250 800 8	415 - 800 8	690 250 800 8	690 250 800 8	690 250 800 8	690 250 800 8
	6 22 25 36 50 25	6 25 50 65 85 40	20 45 120 125 150 40	25 65 180 200 200 40	- - - - 25 -	7.5 (5*) 25 (18*) 25 (18*) 36 (30*) 65 (42*) 40 (30*)	7.5 25 50 65 85 40	20 45 120 125 150 40	25 65 180 200 200 40
	6 22 25 36/30 50 19	6 22 25 36/33 85 40	15 45 80 85 150 40	20 65 135 150 150 40	- - - - 19 -	7.5 (5*) 25 (18*) 25 (18*) 36 (25*) 65 (35*) 40 (25*)	7.5 25 25 36 85 40	15 45 80 85 150 40	20 65 135 150 150 40
	22 50	25 85	45 150	65 200	- 25	22 (18*) 65 (42*)	25 85	45 150	65 200
	■ A	■ A	■ A	■ A	■ A	■ A	■ A	■ A	■ A
	■ • • • • • - • 155 90 120 68 1.1 1.4	■ • • • • • - • 155 90 120 68 1.1 1.4	■ • • • • • - - 165 105 140 103 2.4 3.2	■ • • • • • - - 165 105 140 103 2.4 3.2	■ • • - - - - 165 (35) - 68 (0.5)	■ • • • • • - - 165 105 140 68 1.5 1.9	■ • • • • • - - 165 105 140 68 1.5 1.9	■ • • • • • - - 165 105 140 103 2.5 3.3	■ • • • • • - - 165 105 140 103 2.5 3.3
	■ ■ • •	■ ■ • •	■ ■ • •	■ ■ • •	■ ■ - -	■ ■ • •	■ ■ • •	■ ■ • •	■ ■ • •
	30,000 30,000				20,000 30,000			20,000 30,000	

*Applies only to 20A and 32A models

RATINGS AND SPECIFICATIONS

MCCB ELECTRICAL CHARACTERISTICS TO IEC 60947-2, EN 60947-2, JIS C 8201-2-1 ANN.1, AS/NZS 3947-2, NEMA AB-1

Frame	Quantity	Unit	Condition	250				
				E250	S250	S250	S250	S250
Model				E250	S250	S250	S250	S250
Number of Poles				3, 4	3, 4	3, 4	3, 4	3, 4
Type				NJ	NJ	GJ	NE	GE
Nominal current ratings								
	I_n	(A)	45°C	20,32 50,63 100,125 160,200 250	160 200 250	160 200 250	40, 125, 160 250	40, 125, 160 250
Electrical characteristics								
Rated operational voltage	U_c	(V)	AC 50/60 Hz DC	525 250	690 250	690 250	690 -	690 -
Rated insulation voltage	U_i	(V)		800	800	800	800	800
Rated impulse withstand voltage	U_{imp}	(kV)		8	8	8	8	8
Ultimate breaking capacity (IEC, JIS, AS/NZS)	I_{cu}	(kA)	690V AC 525V AC 440V AC 400/415V AC 220/240V AC 250V DC	- 10 15 25 35 25	7.5 25 25 36 65 40	7.5 25 50 65 85 40	7.5 25 25 36 65 -	7.5 25 50 65 85 -
Service breaking capacity (IEC, JIS, AS/NZS)	I_{cs}	(kA)	690V AC 525V AC 440V AC 400/415V AC 220/240V AC 250V DC	- 7.5 12 19 27 19	7.5 25 25 36 65 40	7.5 25 25 36 85 40	7.5 25 25 36 65 -	7.5 25 25 36 85 -
Rated breaking capacity (NEMA)		(kA)	480V AC 240VAC	10 35	22 65	25 85	25 65	25 85
Rated short-time withstand current	I_{cw}	(kA)	0.3 Seconds	-	-	-	-	-
Protection								
Adjustable thermal, adjustable magnetic				■	■	■		
Fixed thermal, fixed magnetic							■	■
Microprocessor								
Utilisation category				A	A	A	A	A
Installation								
Front connection (FC)				■	■	■	■	■
Extension bar (FB)				•	•	•	•	•
Cable clamp (FW)				•	•	•	•	•
Rear connection (RC)				•	•	•	•	•
Plug-in (PM)				•	•	•	•	•
Draw-out (DR)				-	-	-	-	-
DIN rail mounting (DA)				-	-	-	-	-
Dimensions	h	(mm)		165	165	165	165	165
	w	(mm)	3 pole	105	105	105	105	105
	d	(mm)	4 pole	140	140	140	140	140
	W	(kg)	3 pole	1.5	1.5	1.5	2.3	2.3
Weight			4 pole	1.9	1.9	1.9	3.1	3.1
Operation								
Direct Opening Action				■	■	■	■	■
Toggle operation				■	■	■	■	■
Door mounted (HS, HP) / Breaker mounted handle (HB)				•	•	•	•	•
Motor operation (MC)				•	•	•	•	•
Endurance	Electrical Mechanical	cycles cycles	415V AC	←				

RATINGS AND SPECIFICATIONS

					400										630		
S250	H250	H250	L250	E400	S400	S400	S400	S400	S400	S400	S400	S400	H400	L400	E630	S630	S630
3, 4 PE	3, 4 NJ	3, 4 NE	3, 4 NJ	3, 4 NJ	3, 4 CJ	3, 4 NJ	3, 4 NE	3, 4 GJ	3, 4 GE	3, 4 PJ	3, 4 PE	3, 4 NE	3, 4 NE	3, 4 NE	3, 4 NE	3, 4 CE	3, 4 GE
40, 125, 160, 250	160, 250**	40, 125, 160, 250	160, 250**	250, 400	250, 400	250, 400	250, 400	250, 400	250, 400	250, 400	250, 400	250, 400	250, 400	250, 400	630	630	630
690 - 800 8	690 250 800 8	690 - 800 8	690 250 800 8	525 250 800 8	690 250 800 8	690 250 800 8	690 - 800 8	690 250 800 8	690 - 800 8	690 250 800 8	690 - 800 8	690 - 800 8	690 - 800 8	690 800 8	690* 800 8	690* 800 8	690* 800 8
20 35 50 70 125 -	20 45 120 125 150 40	20 45 120 125 150 -	25 65 180 200 200 40	- 15 22 25 35 25	15 22 30 36 50 40	20 30 45 50 85 40	20 30 45 50 85 -	20 30 45 50 85 40	20 30 65 70 100 40	20 30 65 70 100 -	20 30 80 85 100 40	20 30 80 85 100 -	35 45 120 125 150 -	50 65 180 200 200 -	10* 15 25 36 50 -	20* 30 45 50 85 -	20* 30 65 70 100 -
15 35 50 70 125 -	15 45 80 85 150 40	15 45 80 85 150 -	20 65 135 150 150 40	- 15 22 25 35 19	15 22 30 36 50 40	15 30 45 50 85 40	15 30 45 50 85 -	15 30 45 50 85 40	15 30 50 50 85 40	15 30 80 85 100 40	15 30 80 85 100 -	15 30 80 85 150 -	35 45 80 135 150 150 -	50 65 135 150 150 -	10* 15 25 36 50 -	15* 30 45 50 85 -	15* 30 65 70 100 -
35 125	45 150	45 150	65 200	15 35	22 50	25 85	25 85	30 100	30 100	30 100	30 100	30 100	45 150	65 200	15 50	25 85	30 100
-	-	-	-	-	-	-	5	-	5	-	5	5	5	5	-	-	-
■ A	■ A	■ A	■ A	■ A	■ A	■ A	■ B	■ A	■ B	■ A	■ B	■ B	■ B	■ B	■ A	■ A	■ A
● ● ● - - - 165 105 140 103 2.5 3.3	● ● ● † - - 165 105 140 103 2.4 3.2	● ● ● - - - 165 105 140 103 2.5 3.3	● ● ● † - - 165 105 140 103 2.4 3.2	● ● ● ● ● - 260 140 185 103 4.2 5.6	● ● ● ● ● - 260 140 185 103 4.2 5.6	● ● ● ● ● - 260 140 185 103 4.2 5.6	● ● ● ● ● - 260 140 185 103 4.3 5.7	● ● ● ● ● - 260 140 185 103 4.2 5.6	● ● ● ● ● - 260 140 185 103 4.3 5.7	● ● ● ● ● - 260 140 185 103 4.2 5.6	● ● ● ● ● - 260 140 185 103 4.3 5.7	● ● ● ● ● - 260 140 185 103 4.2 5.7	● ● ● ● ● - 260 140 185 140 103 7.1 9.4	● ● ● ● ● - 260 140 185 140 103 7.1 9.4	● ● ● ● ● - 260 140 185 103 5.0 6.5	● ● ● ● ● - 260 140 185 103 5.0 6.5	● ● ● ● ● - 260 140 185 103 5.0 6.5
■ ■ ● ●	■ ■ ● ●	■ ■ ● ●	■ ■ ● ●	■ ■ ● ●	■ ■ ● ●	■ ■ ● ●	■ ■ ● ●	■ ■ ● ●	■ ■ ● ●	■ ■ ● ●	■ ■ ● ●	■ ■ ● ●	■ ■ ● ●	■ ■ ● ●	■ ■ ● ●	■ ■ ● ●	■ ■ ● ●
10,000 30,000				4,500 15,000											4,500 15,000		

*MCCB cannot be used in IT systems at this voltage.

**Max. rating 225A for Plug-in.

† Refer to Temperature Ratings, Section 6.

‡ Contact us for details.

RATINGS AND SPECIFICATIONS

MCCB ELECTRICAL CHARACTERISTICS TO IEC 60947-2, EN 60947-2, JIS C 8201-2-1 ANN.1, AS/NZS 60947-2, NEMA AB-1

Frame	Quantity	Unit	Condition	800	
Model				S800	S800
Number of Poles				3, 4	3, 4
Type				CJ	NJ
Nominal current ratings					
	I_n	(A)	45°C	630 800	630 800
Electrical characteristics					
Rated operational voltage	U_e	(V)	AC 50/60 Hz DC	690 250	690 250
Rated insulation voltage	U_i	(V)		800	800
Rated impulse withstand voltage	U_{imp}	(kV)		8	8
Ultimate breaking capacity (IEC, JIS, AS/NZS)	I_{cu}	(kA)	690V AC	10*	20*
			525V AC	15*	30
			440V AC	30	50
			400/415V AC	36	50
			220/240V AC	50	85
			250V DC	50	50
Service breaking capacity (IEC, JIS, AS/NZS)	I_{cs}	(kA)	690V AC	10*	20*
			525V AC	15*	30
			440V AC	30	50
			400/415V AC	36	50
			220/240V AC	50	85
			250V DC	50	50
Rated breaking capacity (NEMA)		(kA)	480V AC 240VAC	15 50	30 85
Rated short-time withstand current	I_{cw}	(kA)	0.3 Seconds	-	-
Protection					
Adjustable thermal, adjustable magnetic (TMD)				■	■
Fixed thermal, fixed magnetic (TMF)					
Microprocessor (LSI/LSIG)					
Utilisation category				A	A
Installation					
Front connection (FC)				-	-
Extension bar (FB)				■	■
Cable clamp (FW)				• (3)	• (3)
Rear connection (RC)				•	•
Plug-in (PM)				•	•
Draw-out (DR)				•	•
DIN rail mounting (DA)				-	-
Dimensions	h	(mm)		273	273
	w	(mm)	3 pole 4 pole	210 280	210 280
	d	(mm)		103	103
	Weight	W	(kg)	3 pole 4 pole	8.5 11.5
Operation					
Direct Opening Action				■	■
Toggle operation				■	■
Door mounted (HS, HP) / Breaker mounted handle (HB)				•	•
Motor operation (MC)				•	•
Endurance	Electrical Mechanical	cycles cycles	415V AC	←	4,000 10,000

*MCCB cannot be used in IT systems at this voltage.

■ Standard • Optional - Not Available

RATINGS AND SPECIFICATIONS

						1000		1250			1600	
S800	S800	S800	H800	L800	S1000	S1000	S1250	S1250	S1250	S1600	S1600	
3, 4 RJ	3, 4 NE	3, 4 RE	3, 4 NE	3, 4 NE	3, 4 SE	3, 4 NE	3, 4 SE	3, 4 NE	3, 4 GE	3, 4 SE	3, 4 NE	
630 800	630 800	630 800	630 800	630 800	1000	1000	800 1250	800 1250	800 1250	1600	1600	
690 250 800 8	690 - 800 8	690 - 800 8	690 - 800 8	690 - 800 8	690 - 800 8	690 - 800 8	690 - 800 8	690 - 800 8	690 - 800 8	690 - 800 8	690 - 800 8	
25* 45 65 70 100 50	20* 30 50 50 85 -	25* 35 65 70 100 -	25* 40 125 125 150 -	25* 45 180 200 200 -	20* 30 45 50 85 -	25* 45 65 70 100 -	20* 30 45 50 85 -	25* 45 65 70 100 -	45* 65 85 85 (1) 125 -	20* 30 45 50 85 -	45* 65 85 85 (1) 125 -	
20* 34 50 50 75 50	20* 30 50 50 85 -	20* 30 50 50 75 -	20* 34 94 94 150 -	20* 34 135 150 150 -	15* 23 34 38 65 -	20* 34 50 50 75 -	15* 23 34 38 65 -	20* 34 50 50 75 -	34* 50 65 65 (2) 94 -	15* 23 34 38 65 -	34* 50 65 65 (2) 94 -	
45 100	30 85	35 100	40 150	45 200	30 85	45 100	30 85	45 100	65 125	30 85	65 125	
-	10	10	10	10	-	-	15	15	15	20	20	
■ A	■ B	■ B	■ B	■ B	■ A	■ A	■ B	■ B	■ B	■ B	■ B	
- ■ • (3) • • • -	- ■ • (3) • • • -	- ■ • (3) • • • -	- ■ • • • • -	- ■ • • • • -	- ■ • • • • -	- ■ • • • • -	- ■ • • • • -	- ■ • • • • -	- ■ • • • • -	- ■ • • • • -	- ■ • • • • -	
273 210 280 103 8.5 11.5	273 210 280 103 (4) (5)	273 210 280 103 (4) (5)	273 210 280 140 (6) (7)	273 210 280 140 (6) (7)	273 210 280 103 11.0 14.8	273 210 280 103 11.0 14.8	370 210 280 120 19.8 25.0	370 210 280 120 19.8 25.0	370 210 280 120 19.8 25.0	370 210 280 140 27.0 35.0	370 210 280 140 27.0 35.0	
■ ■ • •	■ ■ • •	■ ■ • •	■ ■ • •	■ ■ • •	■ ■ • •	■ ■ • •	■ ■ • •	■ ■ • •	■ ■ • •	■ ■ • •	■ ■ • •	
			4,000 10,000		4,000 10,000		4,000 5,000			2,000 5,000		

(1) 100kA at 400V
 (2) 75kA at 400V
 (3) 630A only
 (4) 8.7kg/630A, 9.1kg/800A
 (5) 11.9kg/630A, 12.3kg/800A
 (6) 13.3kg/630A, 14.8kg/800A
 (7) 16.8kg/630A, 18.8kg/800A

RATINGS AND SPECIFICATIONS

SWITCH-DISCONNECTOR ELECTRICAL CHARACTERISTICS TO IEC 60947-3, EN 60947-3, AS/NZS 60947-3

Frame	Quantity	Unit	Condition	125	160
Model				S125	S160
Number of Poles				3, 4	3, 4
Type				NN	NN
Nominal current ratings					
	I_e	(A)		125	160
Electrical characteristics					
Rated operational voltage	U_e	(V)	AC 50/60 Hz DC	690 250	690 250
Rated insulation voltage	U_i	(V)		800	800
Rated impulse withstand voltage	U_{imp}	(kV)		8	8
Rated short-circuit making capacity	I_{cm}	(kA peak)		3.6	6
Rated short-time withstand current	I_{cw}	(kA rms)	0.3 Seconds	2	3
Utilisation category to IEC 60947-3			AC DC	AC-23A DC-22A	AC-23A DC-22A
Installation					
Front connection (FC)				■	■
Extension bar (FB)				•	•
Cable clamp (FW)				•	•
Rear connection (RC)				•	•
Plug-in (PM)				•	•
Draw-out (DR)				-	-
DIN rail mounting (DA)				•	-
Dimensions	h	(mm)		155	165
	w	(mm)	3 pole	90	105
			4 pole	120	140
	d	(mm)		68	68
Weight	W	(kg)	3 pole	1.1	1.5
			4 pole	1.4	1.9
Operation					
Direct Opening Action				■	■
Toggle operation				■	■
Door mounted (HS, HP) / Breaker mounted handle (HB)				•	•
Motor operation (MC)				•	•
Endurance	Electrical	cycles	415V AC	30,000	10,000
	Mechanical	cycles		30,000	30,000

RATINGS AND SPECIFICATIONS

	250	400	630	800	1000	1250	1600
	S250	S400	S630	S800	S1000	S1250	S1600
	3, 4 NN	3, 4 NN	3, 4 NN	3, 4 NN	3, 4 NN	3, 4 NN	3, 4 NN
	250	400	630	630 800	1000	1250	1600
	690 250 800 8	690 250 800 8	690 250 800 8	690 250 800 8	690 250 800 8	690 250 800 8	690 250 800 8
	6 3 AC-23A DC-22A	9 5 AC-23A DC-22A	9 5 (3) AC-23A DC-22A	17 10 AC-23A DC-22A	17 10 AC-23A DC-22A	32 15 AC-23A DC-22A	45 20 AC-23A DC-22A
	■ • • • • - - 165 105 140 68 1.5 1.9	■ • • • • - - 260 140 185 103 4.2 5.6	■ • • • ‡ - - 260 140 185 103 4.4 5.8	- ■ - • • - - 273 210 280 103 (1) (2)	- ■ - • - - - 273 210 280 103 10.4 14.0	- ■ - • • • - - 370 210 280 120 18.2 23.4	- • - ■ - • - - 370 210 280 140 24.9 32.9
	■ ■ • •	■ ■ • •	■ ■ • •	■ ■ • •	■ ■ • •	■ ■ • •	■ ■ • •
	10,000 30,000	4,500 15,000	4,500 15,000	← 4,000 10,000 →	4,000 5,000	4,000 5,000	2,000 5,000

(1) 8.0kg/630A, 8.5kg/800A
 (2) 11.0kg/630A, 11.5kg/800A

(3) 7.6kA/0.1sec.

SAFETY LOCK FOR PLUG-IN VERSIONS



The plug-in MCCB is locked to the base when the toggle is ON. It cannot be removed unless the toggle is OFF or TRIPPED. The safety lock prevents a trip occurring as the MCCB is being removed from the base.

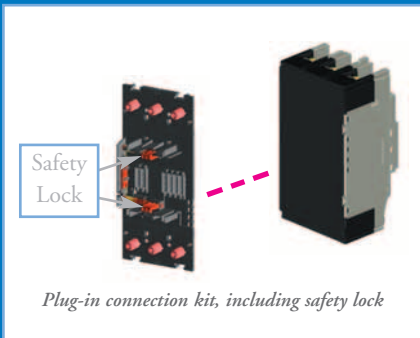

OPERATING CHARACTERISTICS

TEMBREAK 2

MOULDED CASE CIRCUIT BREAKERS 16A TO 1600A

1. Welcome to TemBreak 2	
2. Ratings and Specifications	
3. Operating Characteristics	
• Thermal Magnetic Protection	25
• Thermal Magnetic Time / Current Characteristics	28
• Electronic Protection	
Standard type	36
With LCD	47
• Electronic Time / Current Characteristics	
Standard type	40
With LCD	51
• Let-through Peak Current Characteristics	53
• Let-through Energy Characteristics	60
4. Application Data	
5. Accessories	
6. Installation	
7. Dimensions	



OPERATING CHARACTERISTICS

THERMAL MAGNETIC PROTECTION

TemBreak 2 MCCBs from 125A frame to 800A frame are available with thermal magnetic protection units.

Thermal Magnetic trip units are especially suited to the following applications:

- Installations where harmonic distortion of current waveforms is likely. They operate inherently on the root mean square (rms) heating effect of current.
- DC circuits. Refer to Section 4, “The Application of MCCBs in DC Systems” for more information.

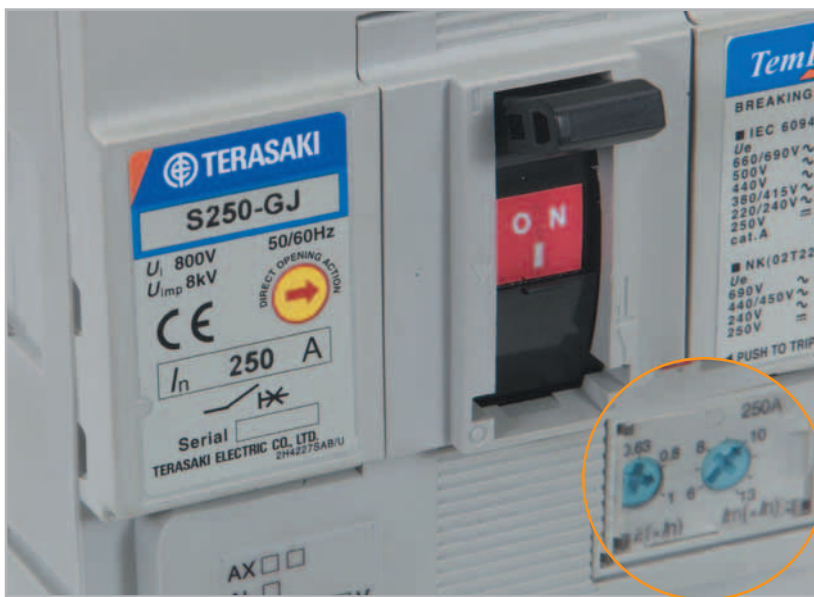

3 Pole MCCB with Adjustable Thermal and Adjustable Magnetic Characteristics



Single Pole MCCB with Fixed Characteristics

Models with Adjustable Thermal and Adjustable Magnetic Characteristics

All standard 3 pole and 4 pole TemBreak 2 thermal magnetic models have adjustable thermal and adjustable magnetic characteristics.

Traditionally, thermal magnetic MCCBs have had adjustable thermal with fixed magnetic characteristics. The fixed magnetic element can limit the application of the MCCB.

An adjustable magnetic characteristic allows short-circuit protection to be matched to the load and supply characteristics, for example motor inrush currents or generator short-circuit currents. Lowering the short-circuit tripping threshold can allow a higher earth-loop impedance in an installation and provide end-of-cable protection with the correct disconnection times.

OPERATING CHARACTERISTICS

THERMAL MAGNETIC PROTECTION

Adjustment Dials

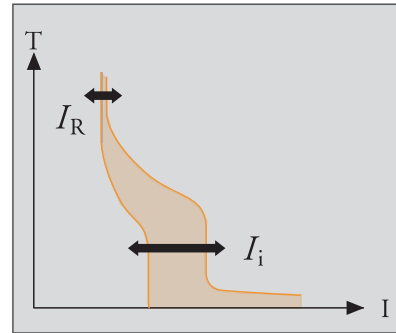
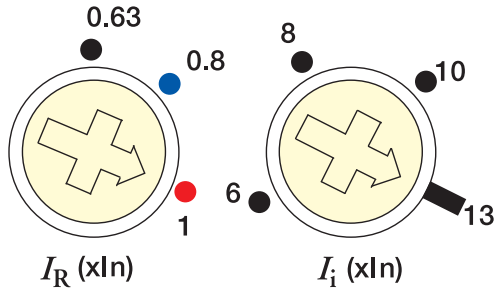

1. I_R is the thermal element adjustment dial and is used to set the rated current to match the conductor rating.
 I_R can be set between 0.63 and 1.0 times I_n .
2. I_i is the magnetic element adjustment dial and is used to set the short circuit tripping threshold to suit the application.

Models, Types, Rated Currents and Magnetic trip currents of Thermal Elements

Model	Type	Rated current I_n (A)	Magnetic trip current I_i (A)
S125	-NF	16, 20, 25, 32, 40, 50, 63, 80, 100	$13 \times I_n$
		125	$12.4 \times I_n$
E125	-NJ	20, 32, 50, 63, 100	$6 - 12 \times I_n$
		125	$6 - 10 \times I_n$
S125	-NJ	20, 32, 50, 63, 100	$6 - 12 \times I_n$
		125	$6 - 10 \times I_n$
S125	-GJ	20, 32, 50, 63, 100	$6 - 12 \times I_n$
		125	$6 - 10 \times I_n$
H125	-NJ	20, 32, 50, 63, 100, 125	$6 - 12 \times I_n$
L125	-NJ	20, 32, 50, 63, 100, 125	$6 - 12 \times I_n$
S160	-NF	16, 20, 25, 32, 40, 50, 63, 80, 100, 125, 160	$10 \times I_n$
		20, 32, 50, 63, 100, 125	$6 - 12 \times I_n$
S160	-NJ	160	$6 - 13 \times I_n$
		50, 63, 100, 125	$6 - 12 \times I_n$
S160	-GJ	160	$6 - 13 \times I_n$
H160	-NJ	160	$6 - 13 \times I_n$
L160	-NJ	160	$6 - 13 \times I_n$
		20, 32, 50, 63, 100, 125	$6 - 12 \times I_n$
E250	-NJ	160, 200	$6 - 13 \times I_n$
		250	$6 - 10 \times I_n$
S250	-NJ	160, 200	$6 - 13 \times I_n$
		250	$6 - 10 \times I_n$
S250	-GJ	160, 200	$6 - 13 \times I_n$
		250	$6 - 10 \times I_n$
H250	-NJ	160	$6 - 13 \times I_n$
		250 (225A for Plug-in)	$6 - 10 \times I_n$
L250	-NJ	160	$6 - 13 \times I_n$
		250 (225A for Plug-in)	$6 - 10 \times I_n$
E400	-NJ	250, 400	$6 - 12 \times I_n$
S400	-CJ	250, 400	$6 - 12 \times I_n$
S400	-NJ	250, 400	$6 - 12 \times I_n$
S400	-GJ	250, 400	$6 - 12 \times I_n$
S800	-CJ	630, 800	$5 - 10 \times I_n$
		630, 800	$5 - 10 \times I_n$
S800	-RJ	630, 800	$5 - 10 \times I_n$

OPERATING CHARACTERISTICS

THERMAL MAGNETIC PROTECTION

Single Pole MCCBs

Single pole models have fixed thermal and fixed magnetic characteristics.

Generator Protection

Generators may need specially modified protection characteristics, based on their short-circuit capability.

If a generator is capable of delivering short-circuit current greater than six times its full load current, a standard TemBreak 2 thermal magnetic MCCB may be used, with I_i set at less than the available short-circuit current. (Note that MCCBs, with fixed magnetic characteristics may not be suitable for this application.)

A thermal magnetic MCCB with low instantaneous protection may be used where the generator short-circuit current is less than six times its full load current. These are modified versions of the standard MCCB.

Four pole MCCBs with low instantaneous protection have protection on the neutral pole as standard. The magnetic characteristic of MCCBs with low instantaneous protection is fixed at the following values:

Model	Magnetic Trip Current
E125	$3xI_n$
S125	$3xI_n$
S160	$3xI_n$
E250	$3xI_n$
S250	$3xI_n$
E400	$3.5xI_n$
S400	$3.5xI_n$

Neutral Pole Protection

Neutral pole protection is available as an optional extra on four pole thermal magnetic MCCBs.

The thermal and magnetic elements in the neutral pole are related to those in the phase poles as follows:

	Phase Trip Threshold	Neutral Trip Threshold
Thermal	I_t (adjustable)	I_N (adjustable) = I_n
Magnetic	I_i (adjustable)	I_i (adjustable)

Motor Protection

MCCBs feeding motors are often only required to provide protection from short-circuits. Overload protection is provided by a dedicated thermal or electronic overload relay. Tembreak 2 MCCBs without thermal protection elements are available for this application. Four pole MCCBs with magnetic trip only have protection on the neutral pole as standard.

OPERATING CHARACTERISTICS

THERMAL MAGNETIC CHARACTERISTICS

Single Pole MCCBs

Time/current characteristic curves

S125-NF

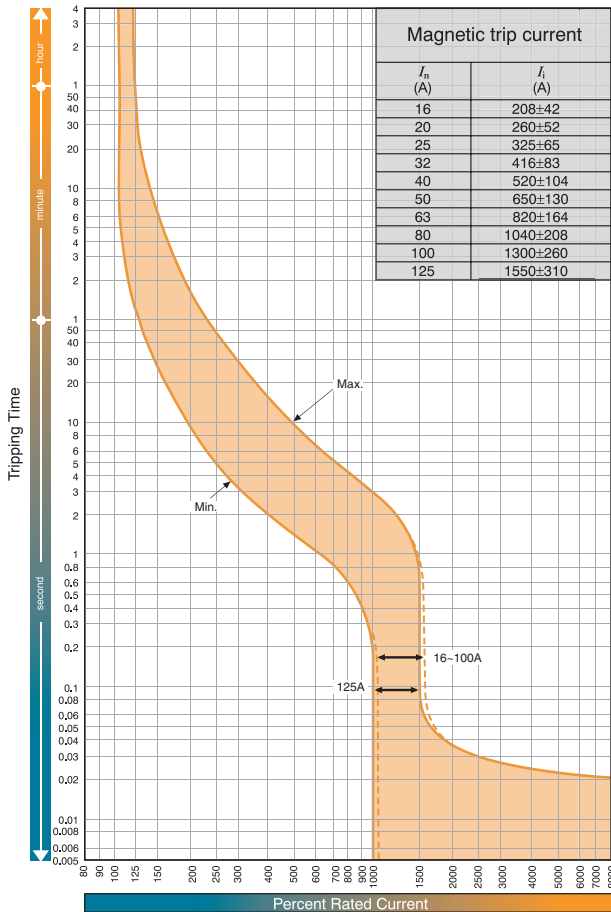

Time/current characteristic curves

S160-NF

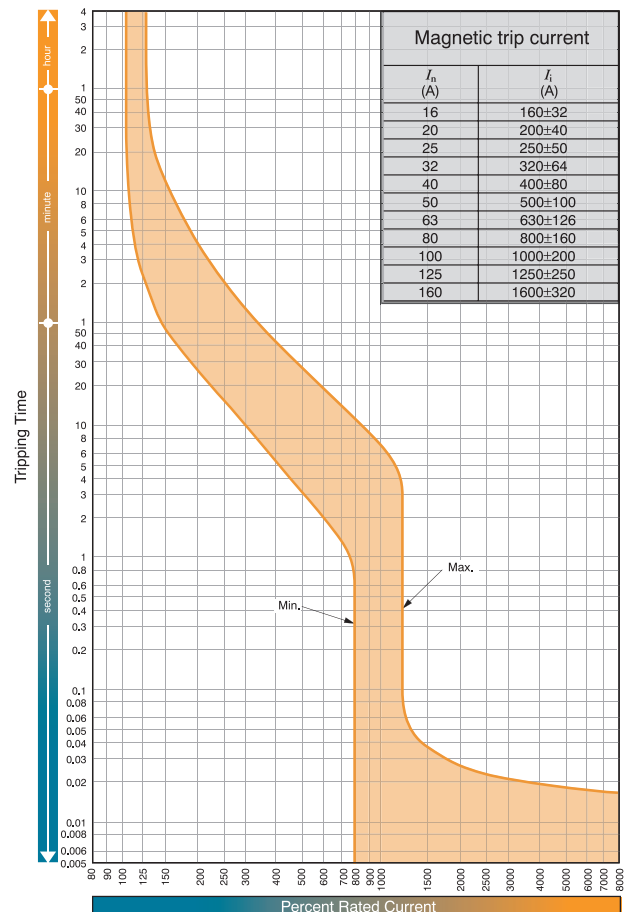

OPERATING CHARACTERISTICS

THERMAL MAGNETIC CHARACTERISTICS

125A Frame

Time/current characteristic curves

E125-NJ, S125-NJ, S125-GJ

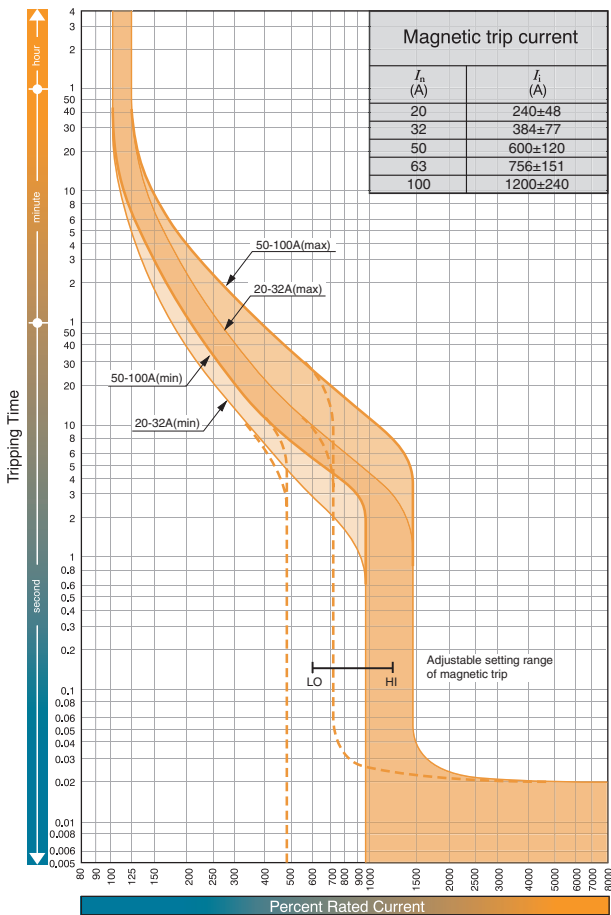

Time/current characteristic curves

E125-NJ, S125-NJ, S125-GJ

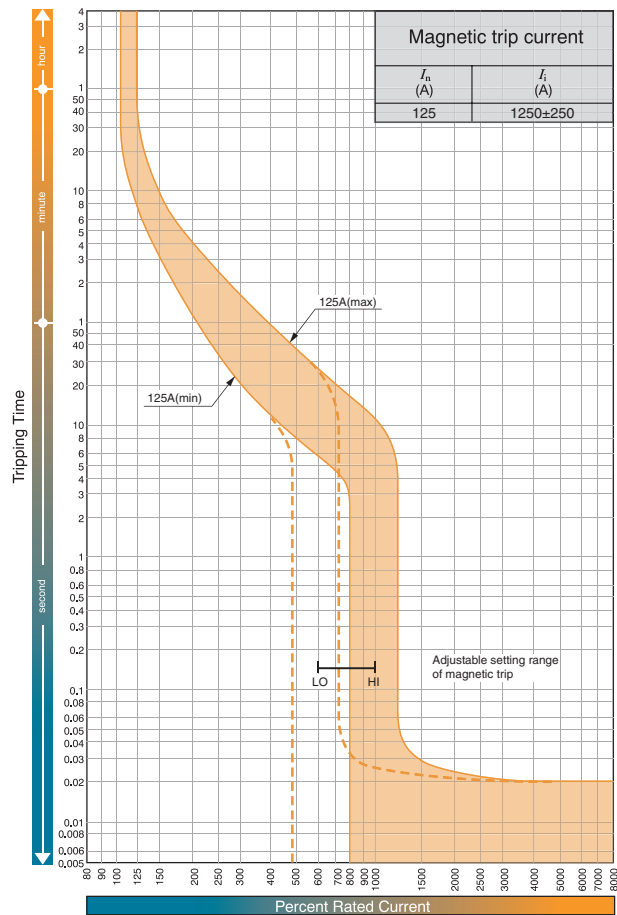

OPERATING CHARACTERISTICS

THERMAL MAGNETIC CHARACTERISTICS

125A Frame

Time/current characteristic curves

H125-NJ, L125-NJ

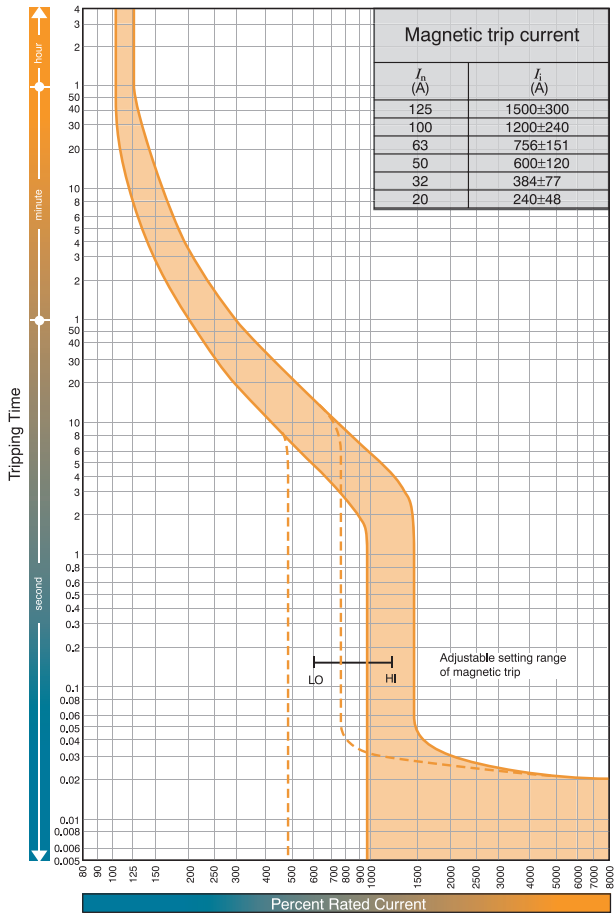

OPERATING CHARACTERISTICS

THERMAL MAGNETIC CHARACTERISTICS

160A and 250A Frames

Time/current characteristic curves

S160-NJ, S160-GJ, E250-NJ, S250-NJ, S250-GJ

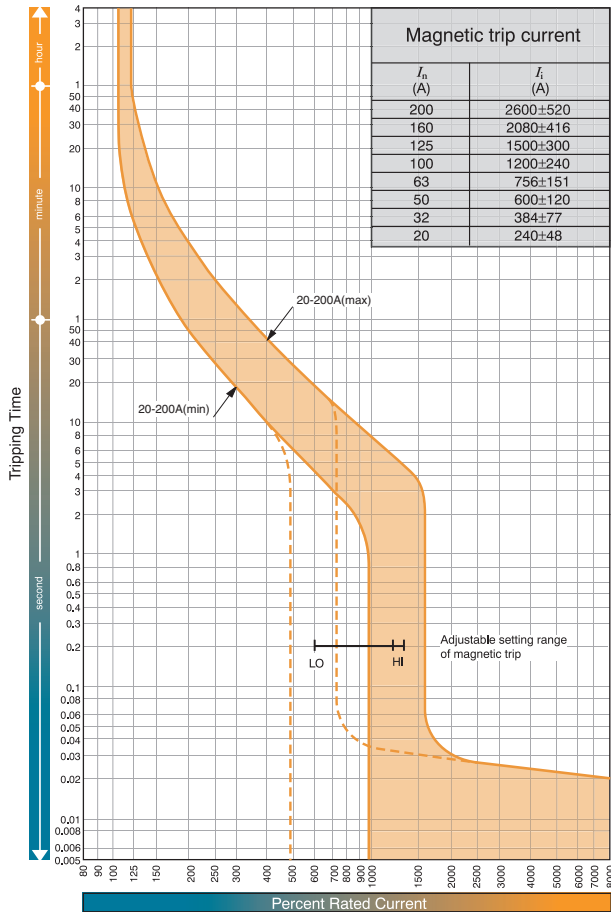

Time/current characteristic curves

E250-NJ, S250-NJ, S250-GJ

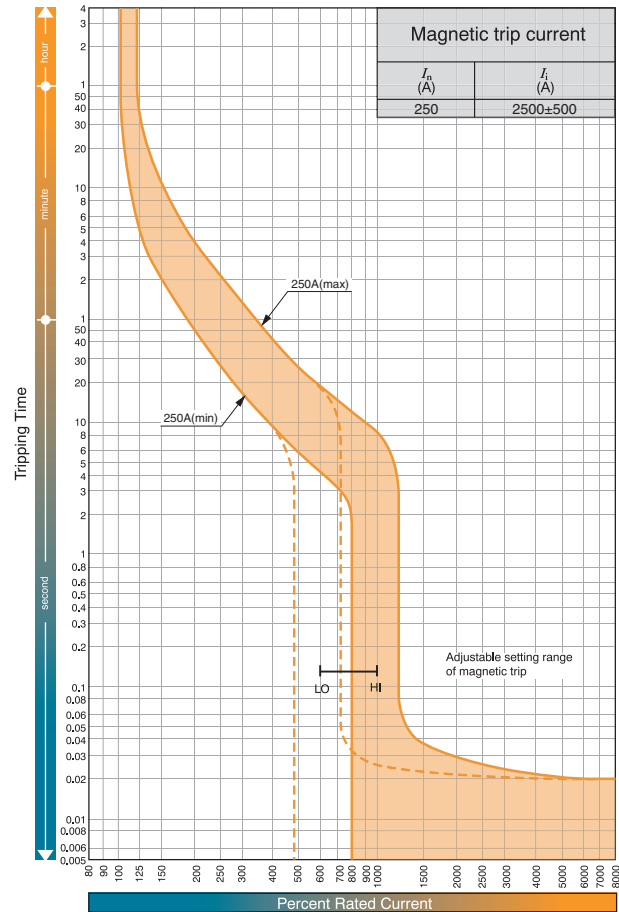

OPERATING CHARACTERISTICS

THERMAL MAGNETIC CHARACTERISTICS

160A and 250A Frames

Time/current characteristic curves

H160-NJ, H250-NJ, L160-NJ, L250-NJ

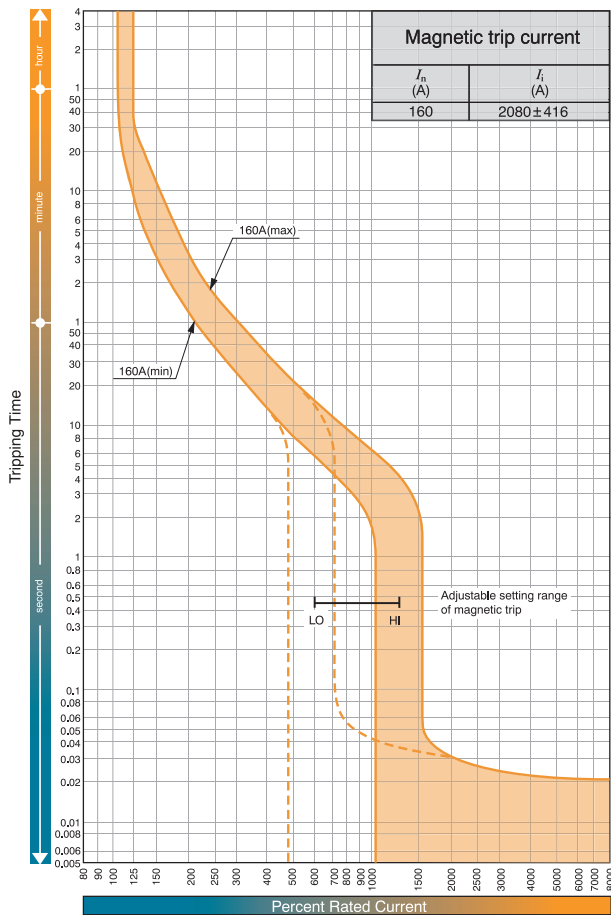

Time/current characteristic curves

H250-NJ, L250-NJ

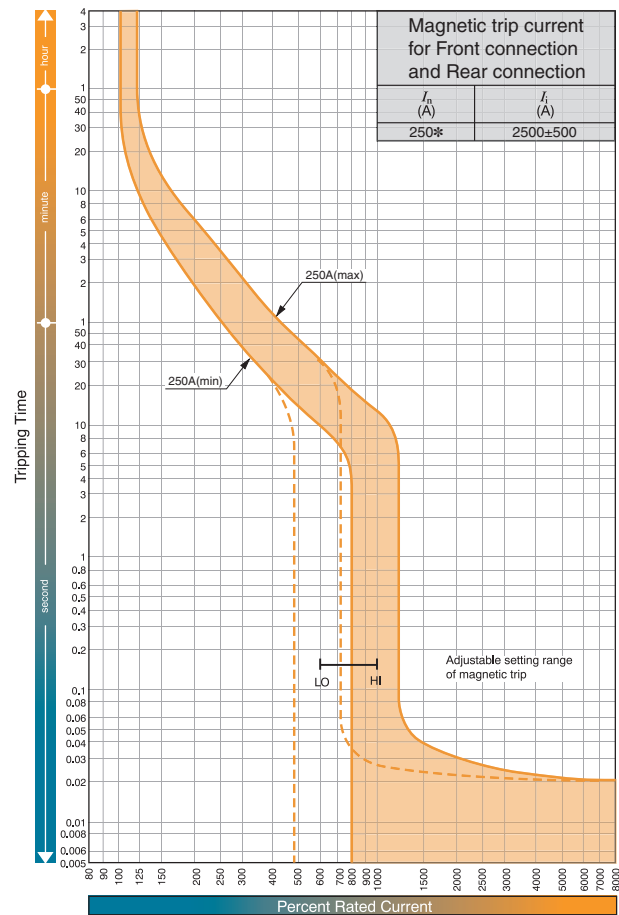

* For Plug-in connection,
Max. rating 225A
 $I_t=2925A\pm585A$

OPERATING CHARACTERISTICS

THERMAL MAGNETIC CHARACTERISTICS

400A Frame

Time/current characteristic curves

E400-NJ, S400-CJ, S400-NJ, S400-GJ, S400-PJ

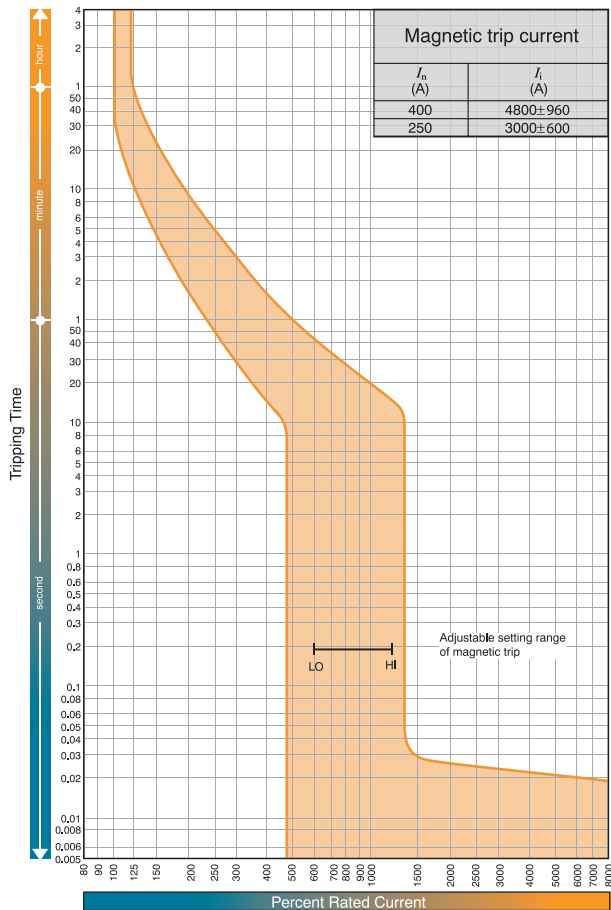

OPERATING CHARACTERISTICS

THERMAL MAGNETIC CHARACTERISTICS

800A Frame

Time/current characteristic curves

S800-CJ, S800-NJ, S800-RJ

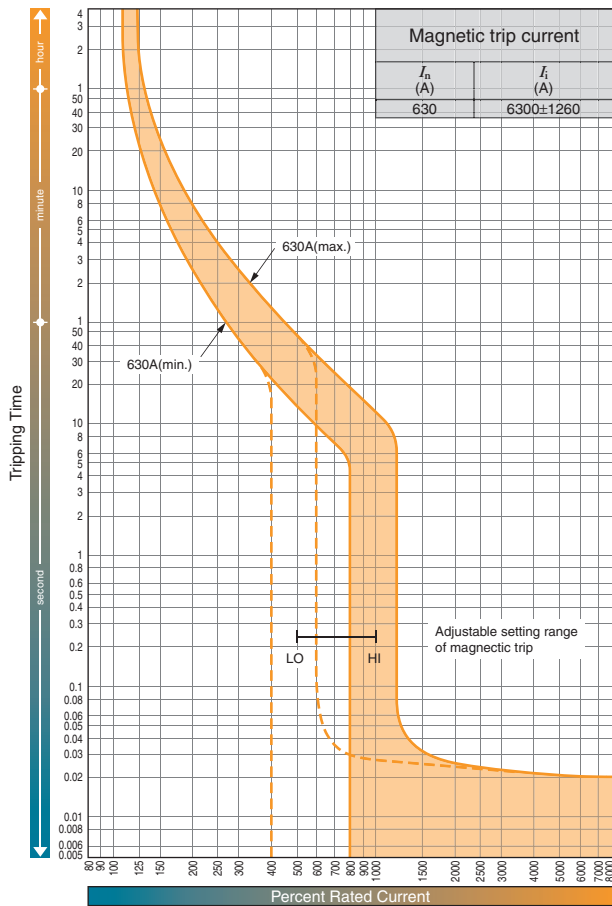

Time/current characteristic curves

S800-CJ, S800-NJ, S800-RJ

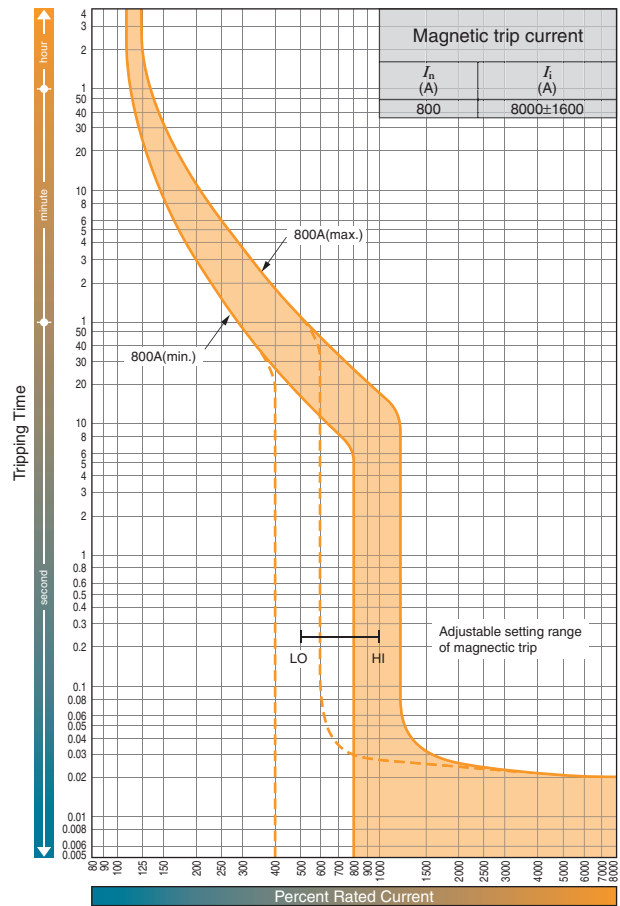

MEMO

A series of horizontal dotted lines for writing.

OPERATING CHARACTERISTICS

ELECTRONIC PROTECTION (STANDARD TYPE)

TemBreak 2 MCCBs from 250A frame to 1600A frame are available with electronic protection units. Current ratings, I_n , of 40A, 125A, 160A, 250A, 400A, 630A, 800A, 1000A, 1250A and 1600A are available. These offer great flexibility as their characteristics can be set to suit a wide range of application conditions. Overload protection can be set between 0.4 and 1.0 times I_n .

Terasaki offer one of the most adaptable protection units on the market:

If you require a characteristic which is not available as a preset on our standard electronic protection unit, send us the details and we will program a customised characteristic to your specification.*

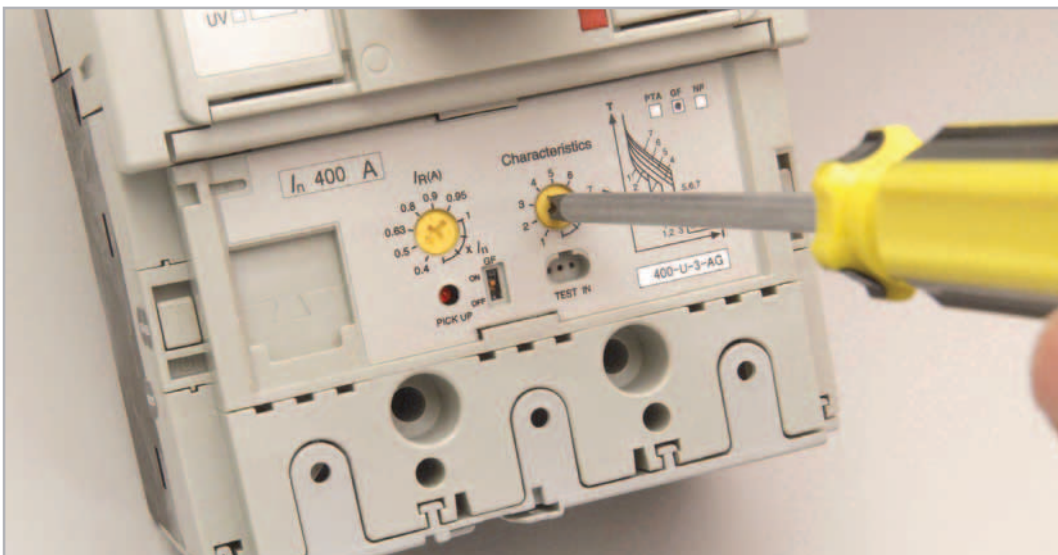

Selecting a Preset Characteristic for a 400A TemBreak 2 MCCB with Electronic Protection

Every TemBreak 2 electronic protection unit includes overload protection (L), delayed short-circuit protection (S) and instantaneous protection (I) as standard.

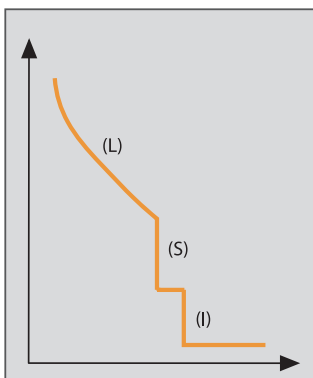

Electronic Protection Characteristic

*Characteristic is programmable within certain limits. Contact us for details.

OPERATING CHARACTERISTICS

ELECTRONIC PROTECTION (STANDARD TYPE)

Optional Functions

Three optional functions are available:

Ground Fault Trip (G)

This function trips the MCCB after time delay, t_g , if the ground fault current exceeds the preset threshold, I_g . Ground fault protection can be enabled and disabled by operating a DIP switch on the electronic protection unit. An external current transformer is available if the ground fault trip function is required on a 3 pole MCCB, in a 3 phase, 4 wire system. The ground fault trip function is available from 400A to 1600A for I_n .

Neutral Protection (N)

Neutral protection trips the MCCB after time delay, t_N , if current in the neutral conductor exceeds the rated current, I_n , of the MCCB. The time delay characteristic is identical to that of the overload characteristic (L).

Preferential Trip Alarm (P)

An LED and volt-free output contact are activated after a time delay, t_p , if the load current exceeds the preset threshold, I_p .

An OCR power supply is required for operation of the preferential trip alarm. This is mounted as shown below, either on the side of the breaker (250A and 400 to 1600A – standard), or remotely (400 to 1600A only – on request). Ratings, specifications and wiring arrangements are shown below. Dimensions of the OCR power supply for preferential trip alarm can be found in Section 7. Note that the breaker mounted terminal block is not compatible with the OCR power supply for Front-Connected and Rear-Connected MCCBs described in Section 5, if the OCR power supply is mounted on the right side of the breaker.

OCR Power Supply Specifications	
Voltage	200-240V AC
Rated Power	2VA

Rated Current of Output Contact		
	resistive load	inductive load
250V AC	2A	2A
220V DC	2A	2A

OPERATING CHARACTERISTICS

ELECTRONIC PROTECTION (STANDARD TYPE)

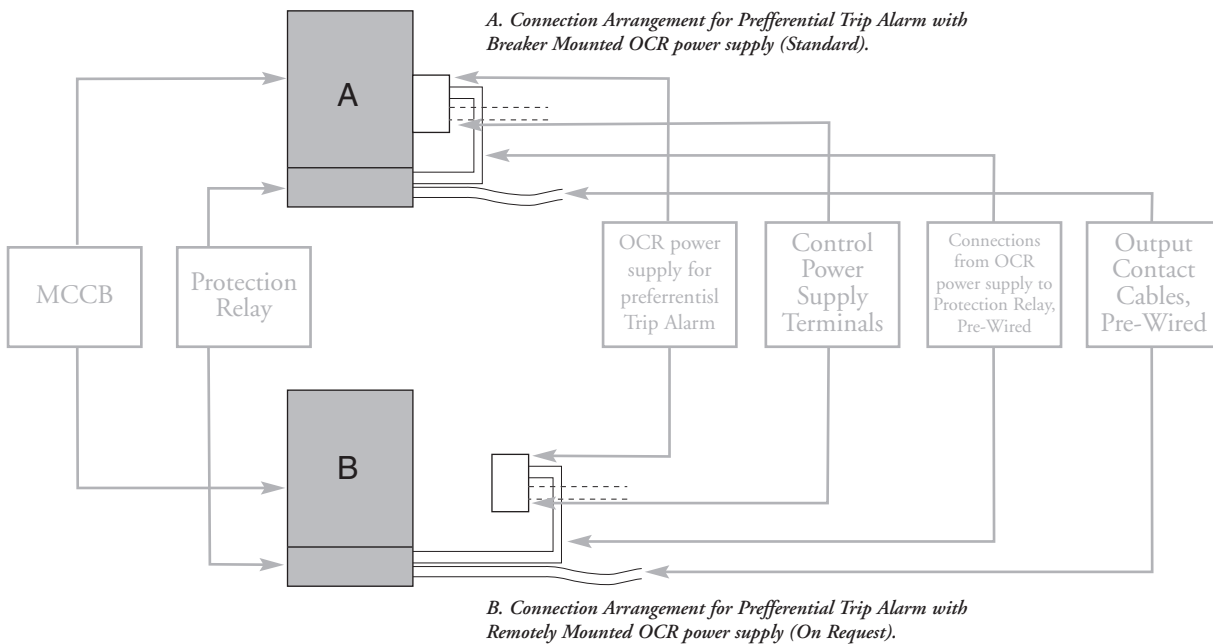

How to Specify Optional Functions

Optional functions must be specified at the time of order. Descriptions for electronic MCCBs include a 1-4 digit alphabetic code after the type designation which details the combination of optional functions. For example:

S400-GE **APG** 3P 400A FC - includes preferential trip and ground fault trip.

The table below lists codes for all the optional functions currently available:

Optional Function					
I_n	Poles	Code	Ground Fault (G)	Neutral Protection (N)	Preferential Trip Alarm (P)
250	3	AP	-	-	■
		AN	-	■	-
	4	APN	-	■	■
		AGN	■	■	-
400	3	AP	-	-	■
		AG	■	-	-
		APG	■	-	■
1000	4	AP	-	-	■
		AN	-	■	-
		APN	-	■	■
		APGN	■	■	■

■ Available - Not Available

OPERATING CHARACTERISTICS

ELECTRONIC PROTECTION (STANDARD TYPE)

Adjustment Dials

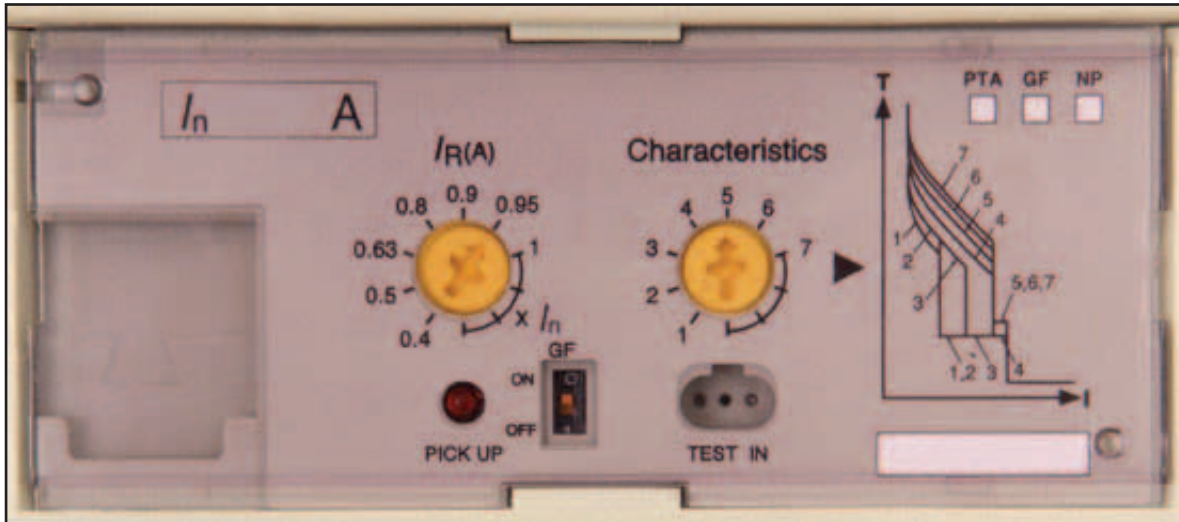

The left adjustment dial sets the rated current to match the conductor rating. The right adjustment dial selects one of seven preset characteristics on 400A, 800A, 1250A and 1600A models, and one of six preset characteristics on 630A and 1000A models, and one of 5 preset characteristics on 250A model. The effects of the left adjustment dial (labelled $I_R(A)$), and the right adjustment dial (labelled Characteristics) are detailed in the tables shown underneath each time / current graph.

Tolerances of Characteristics

Characteristics		Tolerance
Long Time Delay	I_R	Tripping when $(I_R \times 1.05) < \text{load current} \leq (I_R \times 1.25)$
	t_R	$\pm 20\%$
Short Time Delay	I_{sd}	$\pm 15\%$
	t_{sd}	Total clearing time +50ms, resettable time -20ms
Instantaneous	I_i	$\pm 20\%$
Preferential Trip Alarm	I_p	$\pm 10\%$
	t_p	$\pm 10\%$
Ground Fault Trip	I_g	$\pm 15\%$
	t_g	Total clearing time +50ms, resettable time -20ms
Neutral Protection	I_N	Tripping when $(I_N \times 1.05) < \text{load current} \leq (I_N \times 1.3)$

OPERATING CHARACTERISTICS

ELECTRONIC CHARACTERISTICS (STANDARD TYPE)

S250-NE, S250-GE, S250-PE, H250-NE

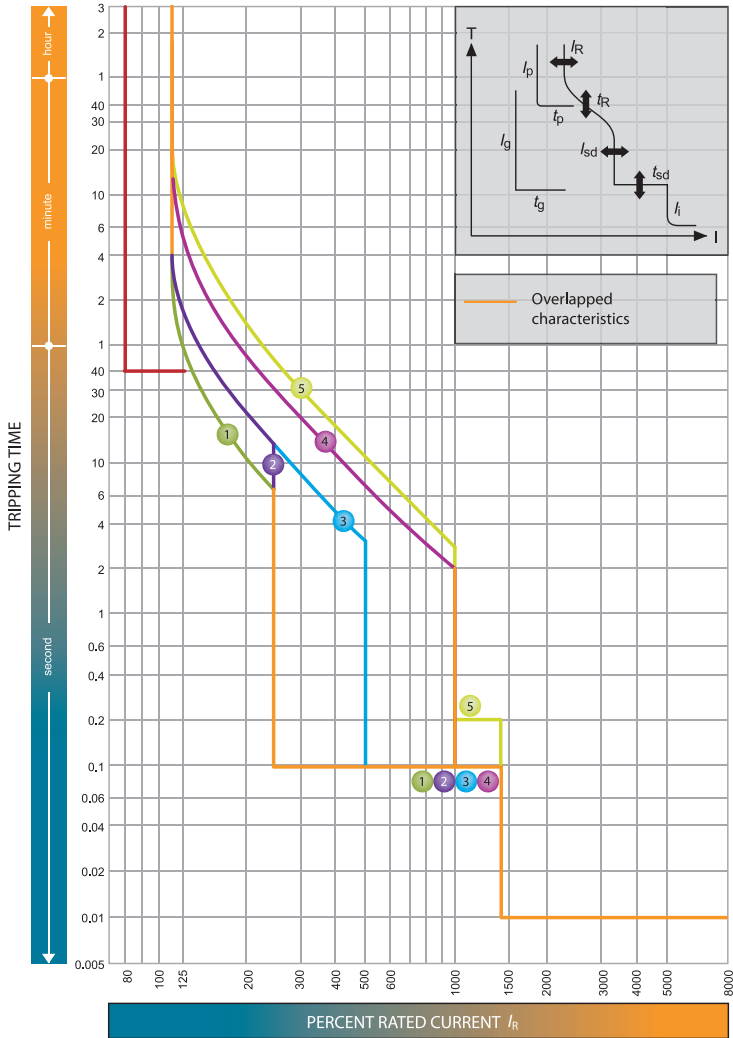

SECTION 3

$I_n = 250A; 160A; 125A; 40A$ Note(1)

		I_R (A)									
		LTD Pick-up current	I_R	x/n	0.4	0.5	0.63	0.8	0.9	0.95	1.0
Standard	Characteristics	No.	1	2	3	4	5				
	LT	t_R (s)	11	21	21	5	7.5				
	ST	I_{sd}	x/I_R	2.5		5	10				
		t_{sd} (s)		0.1				0.2			
INST	I_i	x/I_R	14(Max: $13 \times I_n$) Note (2)								
Option	PTA	I_p	x/I_R	0.8							
		t_p (s)		40							
	NP	I_N	x/I_R	1.0 Note (3)							
		t_N (s)		$t_N = t_R$							

Note

(1) For Plug-in (PM), max. setting for I_R should be less than 225A. When $I_n=250A$, I_R should be $I_n \times 0.9$ or less.

(2) I_i max. = $13 \times I_n$. (3) Characteristic of neutral protection (t_N vs. I_N) is identical to characteristic of phase protection (t_R vs. I_R).

OPERATING CHARACTERISTICS

ELECTRONIC CHARACTERISTICS (STANDARD TYPE)

S400-NE, S400-GE, S400-PE, H400-NE, L400-NE

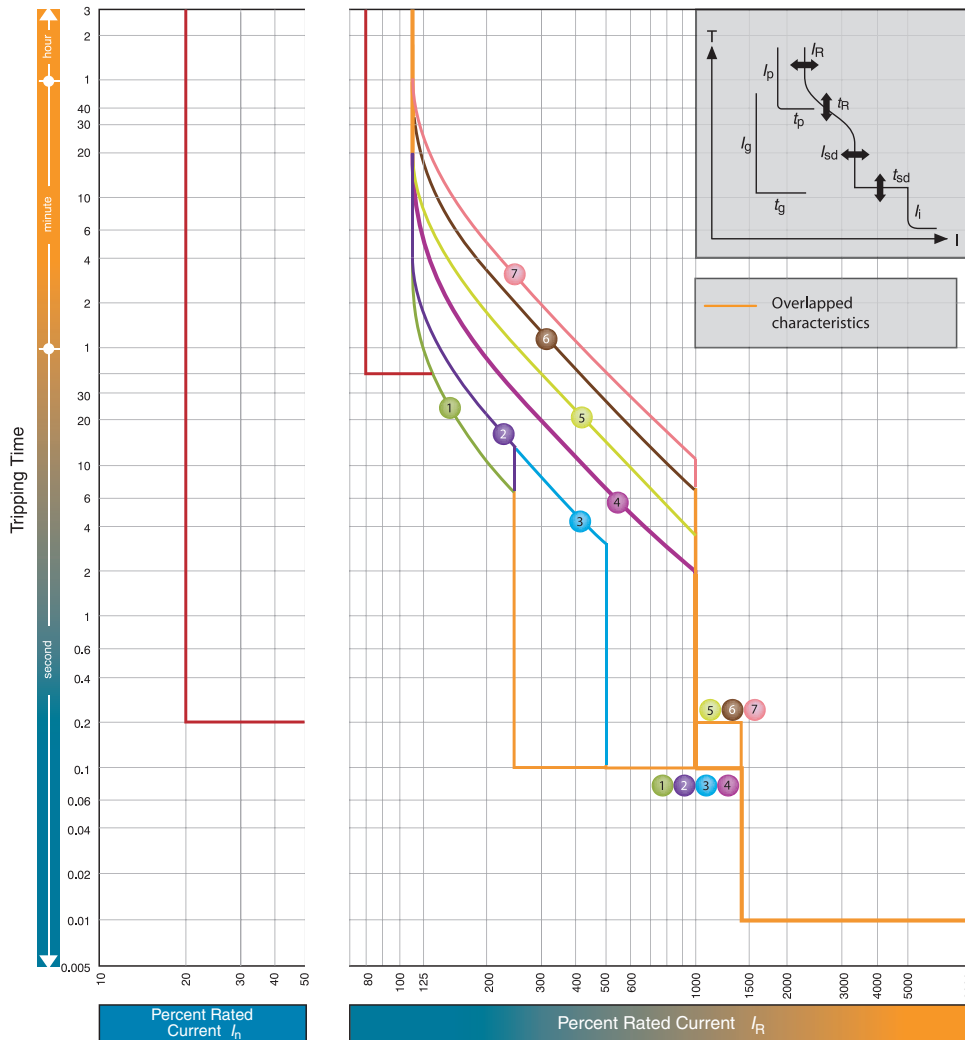

$I_N = 400A; 250A$ Note(1)

		I_R (A)									
		LTD Pick-up current	I_R	x/I_N	0.4	0.5	0.63	0.8	0.9	0.95	1.0
Standard	LT	t_R	(s)		11	21	21	5	10	19	29
	ST	I_{sd}	x/I_R		2.5			5	10		
		t_{sd}	(s)		0.1				0.2		
	INST	I_i	x/I_R		14(Max: $13 \times I_N$) Note (2)						
Option	PTA	I_p	x/I_R		0.8						
		t_p	(s)		40						
	GF Note(4)	I_g	x/I_N		0.2						
		t_g	(s)		0.2						
NP	I_N	x/I_R		1.0/0.5 Note(3)							
	t_N	(s)		$t_N = t_R$							

Note

(1) GF is not available when I_N is 250A. (2) I_i max. = $13 \times I_N$. (3) $1.0 \times I_R$ or $0.5 \times I_R$ can be selected. Characteristic of neutral protection (t_N vs. I_N) is identical to characteristic of phase protection (t_R vs. I_R). (4) When you specify GF on MCCBs with 3 poles the terminal block is automatically fitted to connect with the external neutral CT for 3 phases 4 wires system. See terminal blocks in section 7. GF is not available for 250A I_N .

OPERATING CHARACTERISTICS

ELECTRONIC CHARACTERISTICS (STANDARD TYPE)

E630-NE, S630-CE, S630-GE

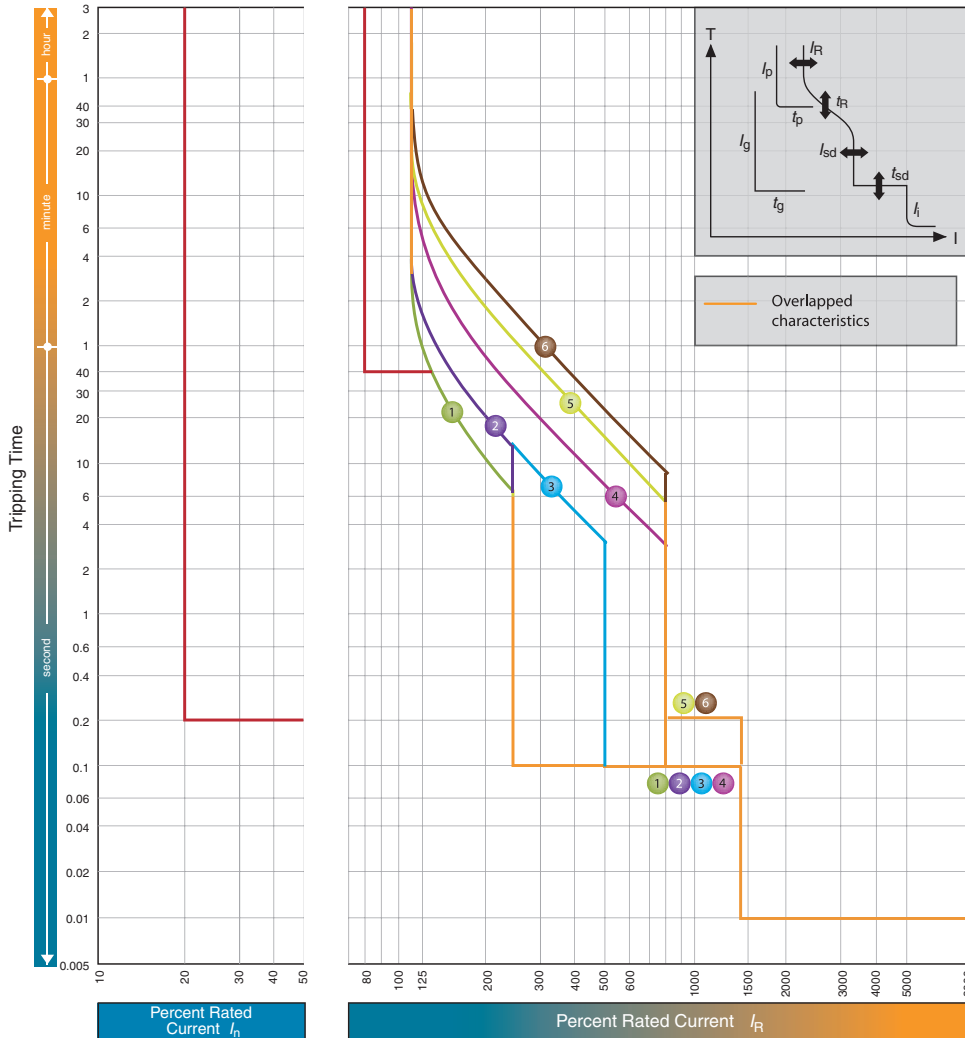

$I_n = 630A$

		I_R (A)									
		LTD Pick-up current I_R	x/I_n	0.4	0.5	0.63	0.8	0.85	0.9	0.95	1.0
Standard	LT	t_R	(s)	11	21	21	5	10	16		
	ST	I_{sd}	x/I_R	2.5			5		8		
		t_{sd}	(s)	0.1				0.2			
	INST	I_i	x/I_R	14(Max: 10 x I_n) Note (1)							
Option	PTA	I_p	x/I_R	0.8							
		t_p	(s)	40							
	GF Note(3)	I_g	x/I_n	0.2							
		t_g	(s)	0.2							
NP	I_N	x/I_R	1.0/0.5 Note(2)								
	t_N	(s)	$t_N = t_R$								

Note

(1) I_i max. = 10 x I_n . (2) 1.0 x I_R or 0.5 x I_R can be selected. Characteristic of neutral protection (t_N vs. I_N) is identical to characteristic of phase protection (t_R vs. I_R). (3) When you specify GF on MCCBs with 3 poles the terminal block is automatically fitted to connect with the external neutral CT for 3 phases 4 wires system. See terminal blocks in section 7.

OPERATING CHARACTERISTICS

ELECTRONIC CHARACTERISTICS (STANDARD TYPE)

S800-NE, S800-RE, H800-NE, L800-NE

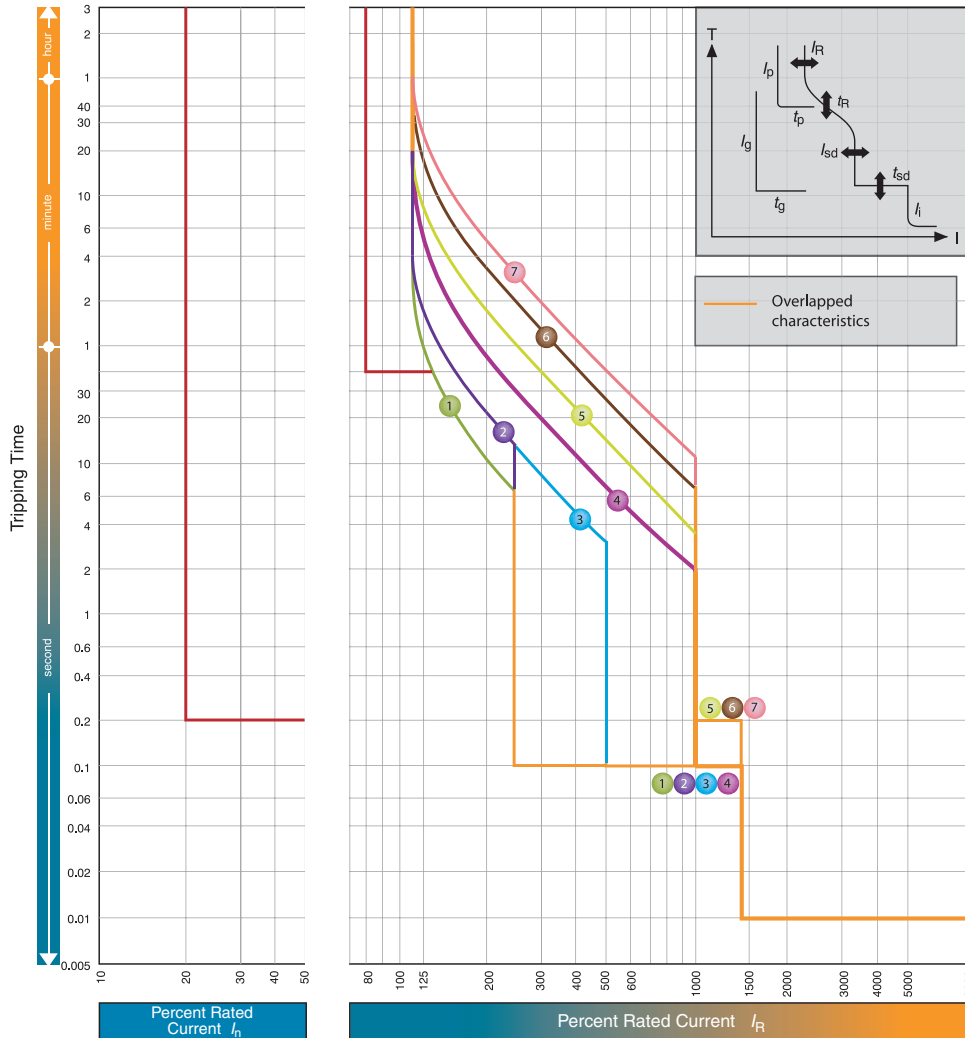

$I_N = 800A; 630A$

		I_R (A)										
		LTD Pick-up current	I_R	x/I_N	0.4	0.5	0.63	0.8	0.9	0.95	1.0	
Standard	LT	t_R	(s)		11	21	21	5	10	19	29	
	ST	I_{sd}	x/I_R		2.5			5	10			
		t_{sd}	(s)		0.1				0.2			
	INST	I_i	x/I_R		14(Max: 12 x I_N) Note (1)							
Option	PTA	I_p	x/I_R		0.8							
		t_p	(s)		40							
	GF Note(3)	I_g	x/I_N		0.2							
		t_g	(s)		0.2							
	NP	I_N	x/I_R		1.0/0.5 Note(2)							
	t_N	(s)		$t_N = t_R$								

Note

(1) I_i max. = 12 x I_N . (2) 1.0 x I_R or 0.5 x I_R can be selected. Characteristic of neutral protection (t_N vs. I_N) is identical to characteristic of phase protection (t_R vs. I_R). (3) When you specify GF on MCCBs with 3 poles the terminal block is automatically fitted to connect with the external neutral CT for 3 phases 4 wires system. See terminal blocks in section 7.

OPERATING CHARACTERISTICS

ELECTRONIC CHARACTERISTICS (STANDARD TYPE)

S1000-SE, S1000-NE

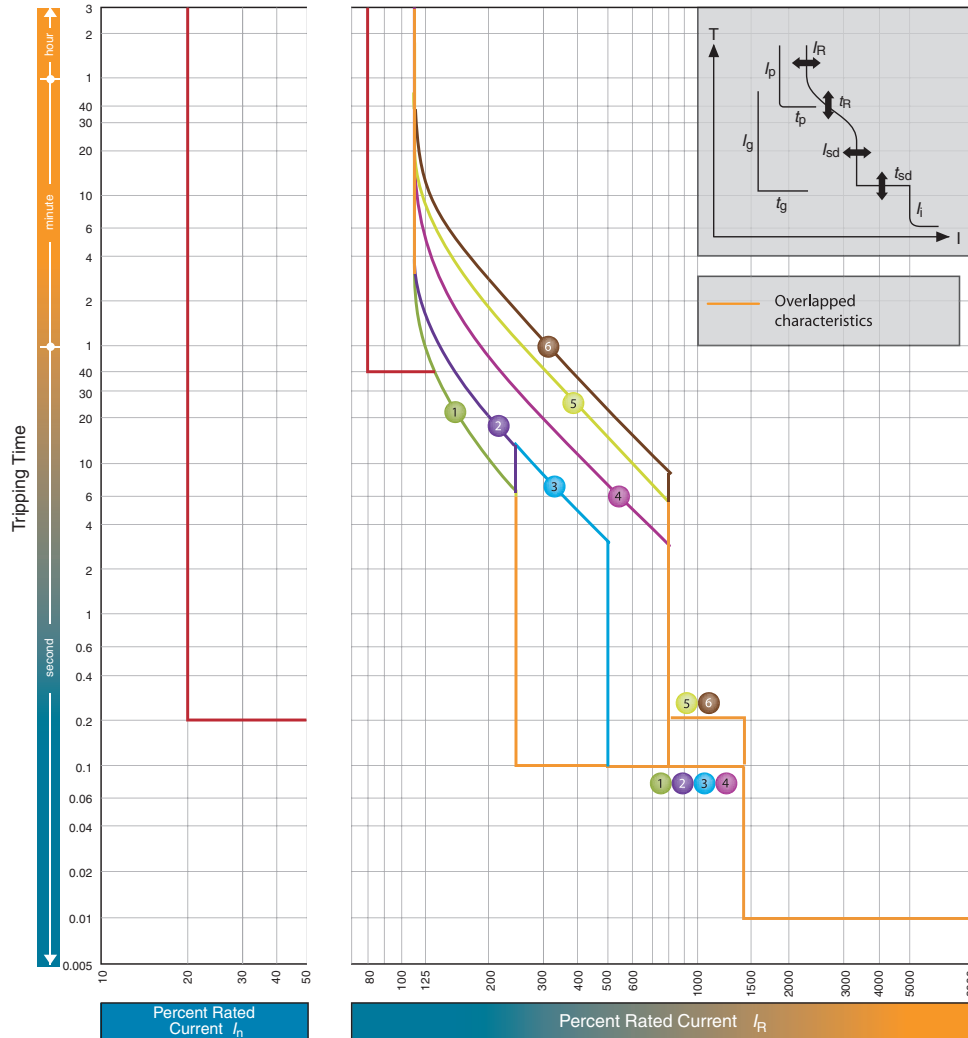

$I_n = 1000A$

		I_R (A)									
		LTD Pick-up current	I_R	x/I_n	0.4	0.5	0.63	0.8	0.9	0.95	1.0
Standard	LT	t_R	(s)		11	21	21	5	10	16	
	ST	I_{sd}	x/I_R		2.5			5			8
		t_{sd}	(s)		0.1			0.2			
	INST	I_i	x/I_R	14(Max: $10 \times I_n$) Note (1)							
Option	PTA	I_p	x/I_R	0.8							
		t_p	(s)	40							
	GF Note(3)	I_g	x/I_n	0.2							
		t_g	(s)	0.2							
NP	I_N	x/I_R	1.0/0.5 Note(2)								
	t_N	(s)	$t_N = t_R$								

Note

(1) I_i max. = $10 \times I_n$. (2) $1.0 \times I_R$ or $0.5 \times I_R$ can be selected. Characteristic of neutral protection (t_N vs. I_N) is identical to characteristic of phase protection (t_R vs. I_R). (3) When you specify GF on MCCBs with 3 poles the terminal block is automatically fitted to connect with the external neutral CT for 3 phases 4 wires system. See terminal blocks in section 7.

OPERATING CHARACTERISTICS

ELECTRONIC CHARACTERISTICS (STANDARD TYPE)

S1250-SE, S1250-NE, S1250-GE

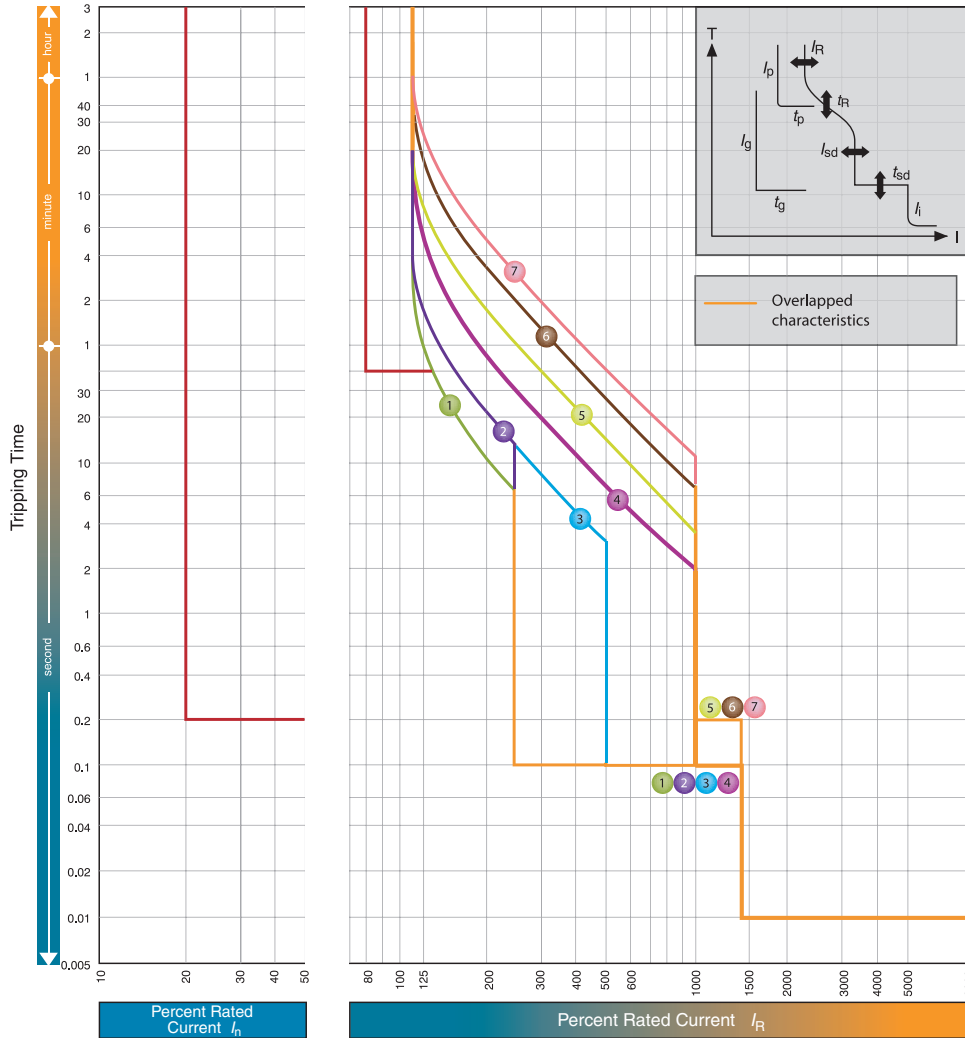

$I_N = 800A; 1250A$

		I_R (A)										
		LTD Pick-up current	I_R	x/I_N	0.4	0.5	0.63	0.8	0.9	0.95	1.0	
Standard	LT	t_R	(s)		11	21	21	5	10	19	29	
	ST	I_{sd}	x/I_R		2.5			5			10	
		t_{sd}	(s)		0.1				0.2			
	INST	I_i	x/I_R		14(Max: 12 x I_N) Note (1)							
Option	PTA	I_p	x/I_R		0.8							
		t_p	(s)		40							
	GF Note(3)	I_g	x/I_N		0.2							
		t_g	(s)		0.2							
NP	I_N	x/I_R		1.0/0.5 Note(2)								
	t_N	(s)		$t_N = t_R$								

Note

(1) I_i max. = 12 x I_N . (2) 1.0 x I_R or 0.5 x I_R can be selected. Characteristic of neutral protection (I_N vs. I_N) is identical to characteristic of phase protection (I_R vs. I_R). (3) When you specify GF on MCCBs with 3 poles the terminal block is automatically fitted to connect with the external neutral CT for 3 phases 4 wires system. See terminal blocks in section 7.

OPERATING CHARACTERISTICS

ELECTRONIC CHARACTERISTICS (STANDARD TYPE)

S1600-SE, S1600-NE

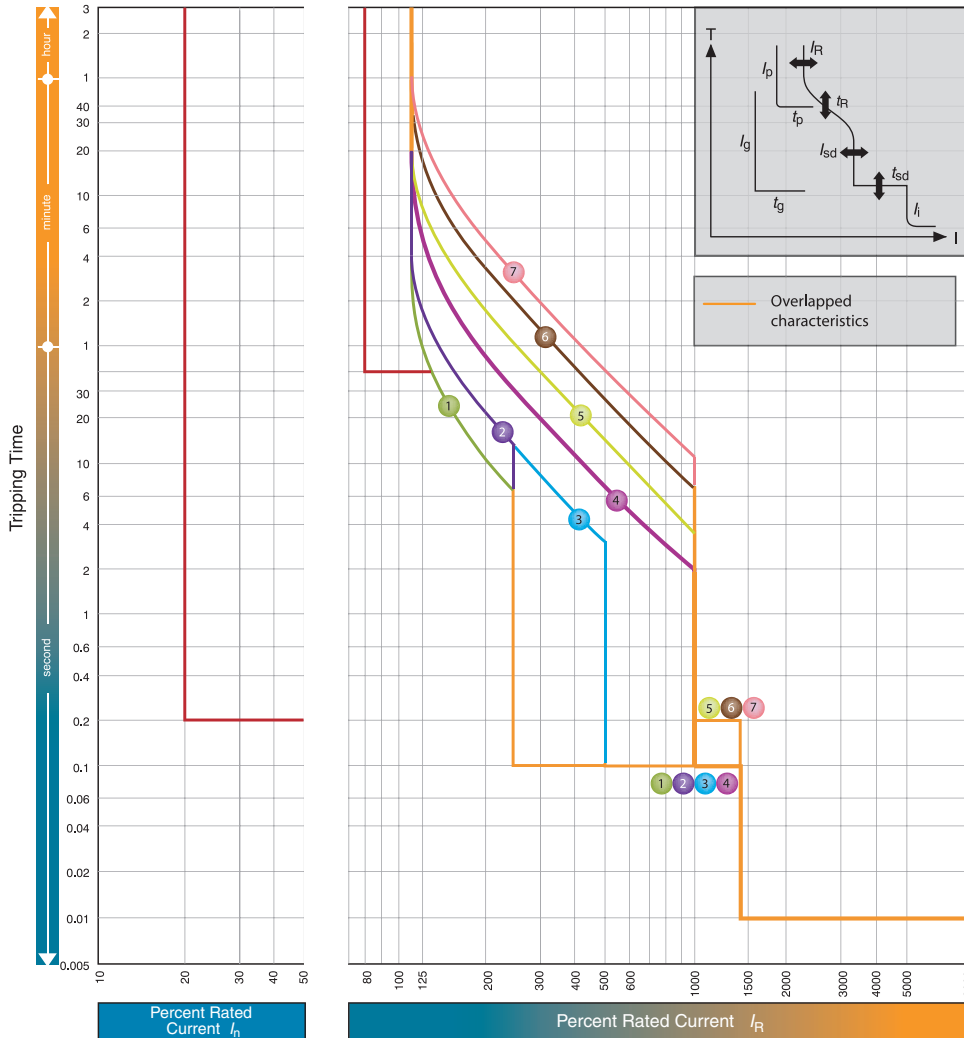

$I_n = 1600A$

		I_R (A)									
		LTD Pick-up current	I_R	x/I_n	0.4	0.5	0.63	0.8	0.9	0.95	1.0
Standard	LT	t_R	(s)		11	21	21	5	10	19	29
	ST	I_{sd}	x/I_R		2.5			5			
		t_{sd}	(s)		0.1				0.2		
	INST	I_i	x/I_n		14(Max: $12 \times I_n$) Note (1)						
Option	PTA	I_p	x/I_R		0.8						
		t_p	(s)		40						
	GF Note(3)	I_g	x/I_n		0.2						
		t_g	(s)		0.2						
	NP	I_N	x/I_R		1.0/0.5 Note(2)						
	t_N	(s)		$t_N = t_R$							

Note

(1) I_i max. = $12 \times I_n$. (2) $1.0 \times I_R$ or $0.5 \times I_R$ can be selected. Characteristic of neutral protection (t_N vs. I_N) is identical to characteristic of phase protection (t_R vs. I_R). (3) When you specify GF on MCCBs with 3 poles the terminal block is automatically fitted to connect with the external neutral CT for 3 phases 4 wires system. See terminal blocks in section 7.

OPERATING CHARACTERISTICS

ELECTRONIC PROTECTION (WITH LCD)

Appearance



The TemBreak2 enhanced electronic breaker with integrated VT and CT monitors the current, voltage, instantaneous electrical power, integrated electrical energy and power factor of a circuit and displays their values on the LCD on the front of the breaker. This breaker using the Modbus protocol allows data such as measured values and event/fault logs to be transmitted to an external device.

- The LCD window provides the phase currents, line voltages (and their maximum values), power factor, electrical power and electrical energy. It can also provide the 1st to 19th harmonic currents for each phase.
- When a fault occurs, the cause of the fault and the fault current are indicated on the LCD. Data in memory is stored even if the power is lost. You can view event or fault logs after the power is restored.

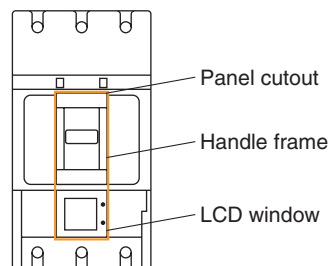

The LCD window is equal to the handle frame in width; the panel cutout can be made easily.

OPERATING CHARACTERISTICS

ELECTRONIC PROTECTION (WITH LCD)

- The breaker is available in three LCD orientations corresponding to the installation orientations of the breaker.

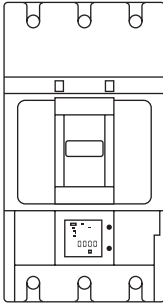
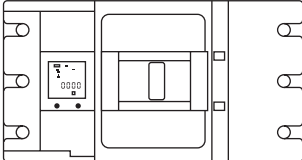
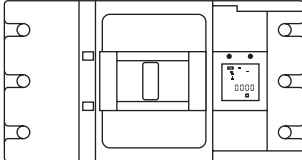
Vertical (move the handle up to ON) (Standard orientation)	Horizontal (move the handle right to ON)	Horizontal (move the handle left to ON)
		

If the breaker is installed in a horizontal orientation, please specify "Horizontal (move the handle right to ON)" or "Horizontal (move the handle left to ON)" when ordering. Otherwise the standard orientation "Vertical (move the handle up to ON)" will apply.

OCR Power Supply for Electronic Protection with LCD

The XOW OCR, protection relays, requires control power.

The OCR power supply is installed on the right side of the breaker as standard. This can also be installed separately to the breaker. Please specify when ordering.

Note ①: When the OCR power supply is installed on the right side of the breaker, the breaker cannot be equipped with a terminal block for connection to the shunt trip device and under voltage trip device.

• Specifications of OCR power supply

Control voltage Note ② (Rated voltage)	100 – 120 VAC or 200 – 240 VAC
Current consumption	2VA

Note ②: The permissible range of the control voltage is 85 to 110% of the rated voltage. Please specify the rated voltage when ordering.

Dimensions of the OCR power supply can be found in Section 7.

OPERATING CHARACTERISTICS

ELECTRONIC PROTECTION (WITH LCD)

Available types

Type of OCR	Protective function				Alarm function	Display		
	Long time-delay trip Short time-delay trip Instantaneous trip	Ground fault trip	N-phase protection	Phase rotation protection	Pre-trip alarm	LCD window	LCD backlight	
	A	GF	NP	NS	PTA			
XOW-1L-A	●	—	—	—	—	●	—	
XOW-1L-AGN	●	●	●	—	—	●	—	
XOW-1L-AP	●	—	—	—	●	●	—	
XOW-1L-APGNS	●	●	●	●	●	●	—	
XOW-1L-APC	●	—	—	—	●	●	—	
XOW-1L-APGNSC	●	●	●	●	●	●	—	
XOW-1S-A	●	—	—	—	—	●	●	
XOW-1S-AGN	●	●	●	—	—	●	●	
XOW-1S-AP	●	—	—	—	●	●	●	
XOW-1S-APGNS	●	●	●	●	●	●	●	
XOW-1S-APCWH	●	—	—	—	●	●	●	
XOW-1S-APGNSCWH	●	●	●	●	●	●	●	

- : Standard equipment
- : Optional
- : Not applicable

Measurement/event indication function specifications

Measurement/event (accuracy)		Modbus communication function ○ : Yes —: Non	Note
Load current (±1.5%)	Present value for each phase	○	Ground fault current and negative-phase current can be displayed depending on the specifications.
	Present max value	○	Among L1, L2, L3 phases, the phase having the highest current is subject to measurement and the value of the current is displayed.
Line voltage (±1.0%)	Present value of each line voltage	○	
	Present max value	○	
	Present phase voltage value for each phase	○	Applies to 4-pole breakers only.
Harmonic current (±2.5%)	Present value of 3rd, 5th, 7th, ...19th harmonic current for each phase	—	
Electrical power (±2.5%)	Present value	○	
	Demand value	○	
	Max demand value	○	
Electrical energy (±2.5%)	Electrical energy	○	
Power factor (±5%)	Present value	○	
Trip event log	Fault current (±1.5%)	○	
	Indication of cause	○	
Alarm event log	Cause of alarm, Indication of operated value	○	

Note: Electrical energy is stored every 2 hours and the fault current and cause of fault are stored every time a fault occurs in a flash memory.

OPERATING CHARACTERISTICS

Measurement/event indication							Communication function	External indicator	Test function	Indication via output contact	Control power supply
Current	Voltage, electrical power, electrical energy, power factor, demand electrical power	Electrical energy pulse	Harmonic current	Trip event log	Alarm event log						
		W	H			C	I		Y		
●	—	—	—	●	●	—	—	●	—	Required	
●	—	—	—	●	●	—	—	●	—	Required	
●	—	—	—	●	●	—	—	●	●	Required	
●	—	—	—	●	●	●	—	●	●	Required	
●	—	—	—	●	●	●	—	●	●	Required	
●	●	—	—	●	●	—	—	●	—	Required	
●	●	—	—	●	●	—	—	●	—	Required	
●	●	—	—	●	●	—	—	●	●	Required	
●	●	●	●	●	●	●	○	●	●	Required	
●	●	●	●	●	●	●	○	●	●	Required	

Network interface I/O specifications

Item	Modbus line
Communication protocol	RS-485
Communication mode	2-wire, half-duplex
Topology	Multi-drop bus
Transmission rate	19.2 kbps max
Transmission distance	1.2 km max (at 19.2 kbps)
Data format	Modbus-RTU
Max number of nodes	1–31

OPERATING CHARACTERISTICS

ELECTRONIC CHARACTERISTICS (WITH LCD)

Specifications of over-current release

Applicable MCCB type	CT rated primary current I_{CT}
S400-NE, S400-GE, S400-PE, H400-NE, L400-NE	250A 400A
E630-NE, S630-CE, S630-GE	630A
S800-NE, S800-RE, H800NE, L800-NE	630A 800A
S1000-SE, S1000-NE	1000A

Protective function		Symbol	Setting range
Rated current (A)		I_n	$[I_{CT}] \times (0.5-0.63-0.8-1.0)$
Long time-delay trip LT	Pick-up current (A)	I_R	$[I_n] \times (0.8-0.85-0.9-0.95-1.0)$ • Non tripping at not more than $[I_R] \times 1.05$ • Tripping at more than $[I_R] \times 1.05$ and not more than $[I_R] \times 1.2$
	Time-delay (s)	t_R	$(0.5-1.25-2.5-5-10-15-20-25-30)$ (sec) at 600% of $[I_R]$ ① Time-delay setting tolerance: $\pm 20\%$, +0.13s –0s
	COLD/HOT	—	COLD/HOT
Short time-delay trip ST	Pick-up current (A)	I_{sd}	$[I_n] \times (1-1.5-2-2.5-3-4-6-8-10-NON)$ ② Current setting tolerance: $\pm 15\%$
	Time-delay (s)	t_{sd}	I^2t OFF: 0.05- <u>0.1</u> -0.2-0.3s (Definite time characteristic), Time-delay setting tolerance: +50ms –20ms I^2t ON: 0.05- <u>0.1</u> -0.2-0.3s (Ramp characteristic at less than 1000% of $[I_n]$, Definite time characteristic at 1000% or more of $[I_n]$) ③
	I^2t ramp characteristic	—	OFF/ON
Instantaneous trip INST	Pick-up current (A)	I_I	$[I_n] \times (2-3-4-6-8-10-12-13-14-NON)$ ④⑤ Current setting tolerance: $\pm 20\%$
Ground fault trip GF	Pick-up current (A)	I_g	$[I_{CT}] \times (0.2-0.3-0.4-NON)$ Current setting tolerance: $\pm 20\%$
	Time-delay (s)	t_g	I^2t OFF: 0.1-0.2- <u>0.3</u> -0.4-0.8s (Definite time characteristic) Time-delay setting tolerance: +50ms –20ms I^2t ON: 0.1-0.2- <u>0.3</u> -0.4-0.8s (Ramp characteristic at less than 40% of $[I_{CT}]$, Definite time characteristic at 40% or more of $[I_{CT}]$)
	I^2t ramp characteristic	—	OFF/ON
	Mode	—	TRIP/OFF ⑥
N-phase protection NP	Pick-up current (A)	I_N	$[I_{CT}] \times (0.4-0.5-0.63-0.8-1.0-NON)$ • Non tripping at not more than $[I_N] \times 1.05$ • Tripping at more than $[I_N] \times 1.05$ and not more than $[I_N] \times 1.2$
	Time-delay (s)	t_N	Tripping at 600% of $[I_N]$ with LT time-delay $[t_R]$.
	COLD/HOT	—	COLD/HOT
Phase rotation protection NS	Pick-up current (A)	I_{NS}	$[I_n] \times (0.2-0.3-0.4-0.5-0.6-0.7-0.8-0.9-1.0)$ Current setting tolerance: $\pm 10\%$
	Time-delay (s)	t_{NS}	$(0.4-0.8-1.2-1.6-2.0-2.4-2.8-3.2-3.6-4.0)$ (sec) at 150% of $[I_{NS}]$ Time-delay setting tolerance: $\pm 20\%$, +0.13s –0s
	Mode	—	TRIP/OFF ⑥
Pre-trip alarm PTA	Pick-up current (A)	I_P	$[I_n] \times (0.7-0.8-0.9-1.0)$ Current setting tolerance: $\pm 10\%$
	Time-delay (s)	t_P	5-10-15-20- <u>40</u> -60-80-120-160-200s more than $[I_P]$ Time-delay setting tolerance: $\pm 10\%$, +0.1s –0s
	Mode	—	AL/OFF ⑥

Note ①: For E630, S630, S1000, (0.5-1.25-2.5-5-10-15-16)sec.

②: For E630, S630, S1000, $[I_n] \times (1-1.5-2-2.5-3-4-6-8-NON)$.

③: For E630, S630, S1000, 800% or more of $[I_n]$.

④: The max. pick-up current is set to 1300% $\times [I_{CT}]$ for S400, H400 and L400, 1000% $\times [I_{CT}]$ for E630, S630 and S1000, 1200% $\times [I_{CT}]$ for S800, H800 and L800.

⑤: When the short time delay trip function has been set to NON, the instantaneous trip function cannot be set to NON. When the instantaneous trip function has been set to NON, the short time delay trip function cannot be set to NON.

⑥: Selecting "OFF" disables protective functions.

Unless otherwise specified when ordering, the settings will default to those underlined in the table above.

OPERATING CHARACTERISTICS

ELECTRONIC CHARACTERISTICS (WITH LCD)

Long time-delay and instantaneous trip

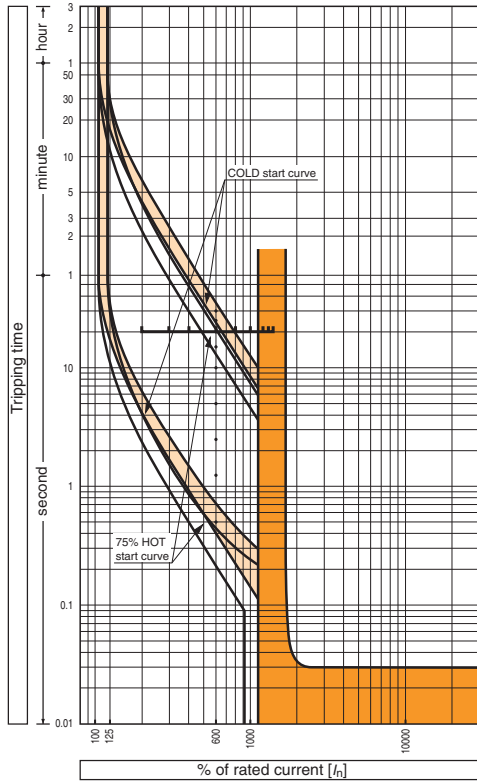

Short time-delay trip

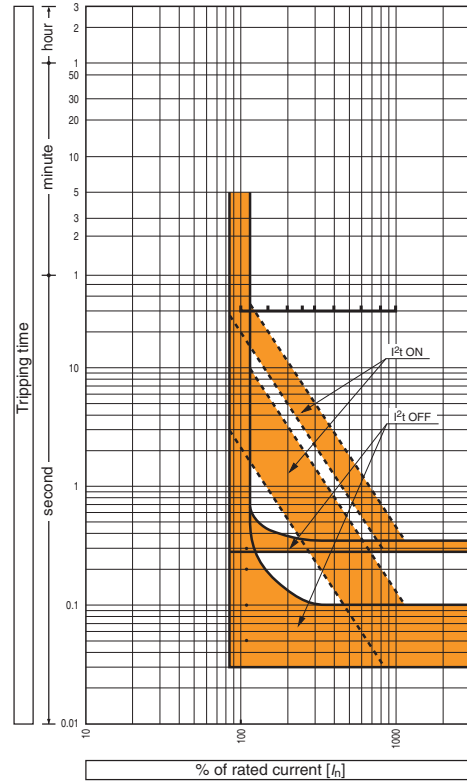

N-phase protection and ground fault trip

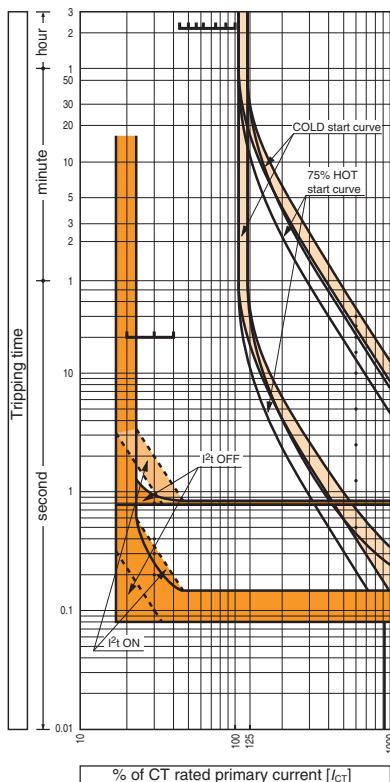

Phase rotation protection and pre-trip alarm

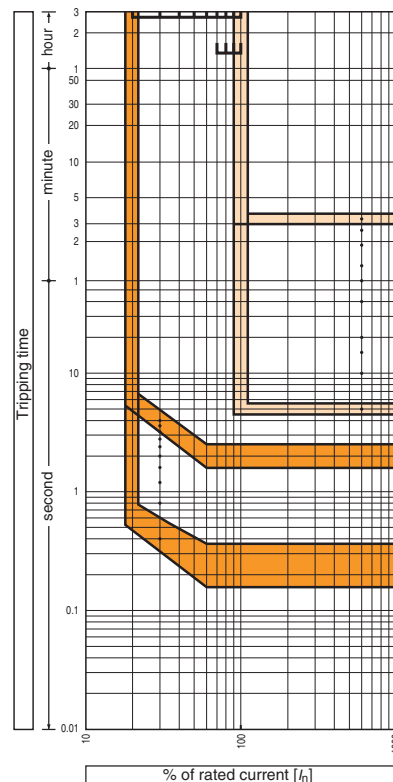

OPERATING CHARACTERISTICS

LET-THROUGH PEAK CURRENT CHARACTERISTICS

S125-NF, 240V AC.

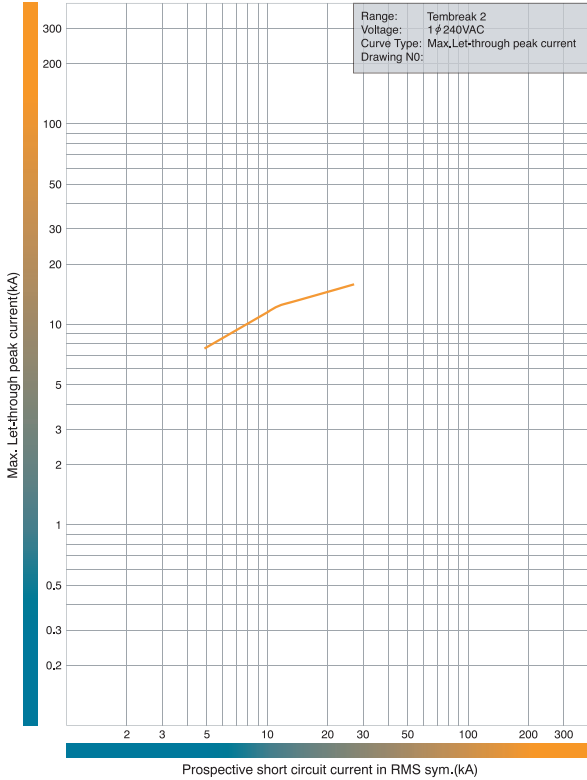

S160-NF, 240V AC.

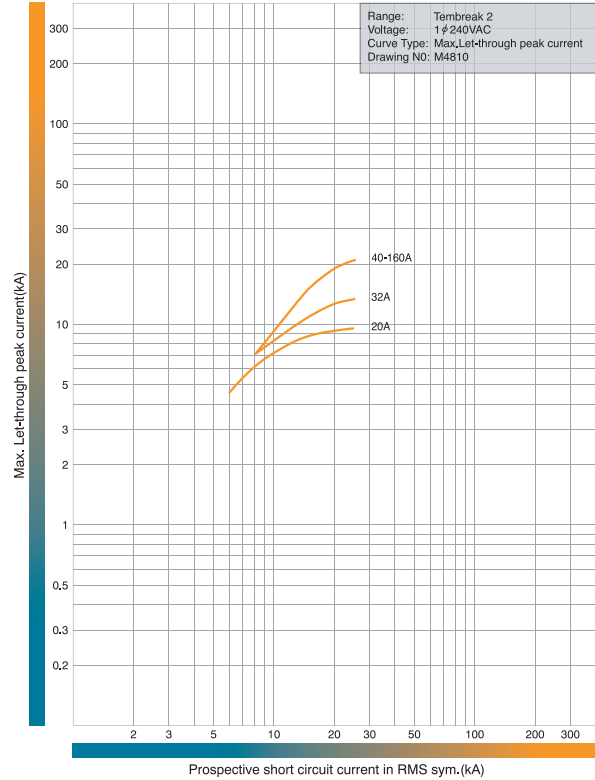

E125-NJ, S125-NJ, S125-GJ. 440V AC.

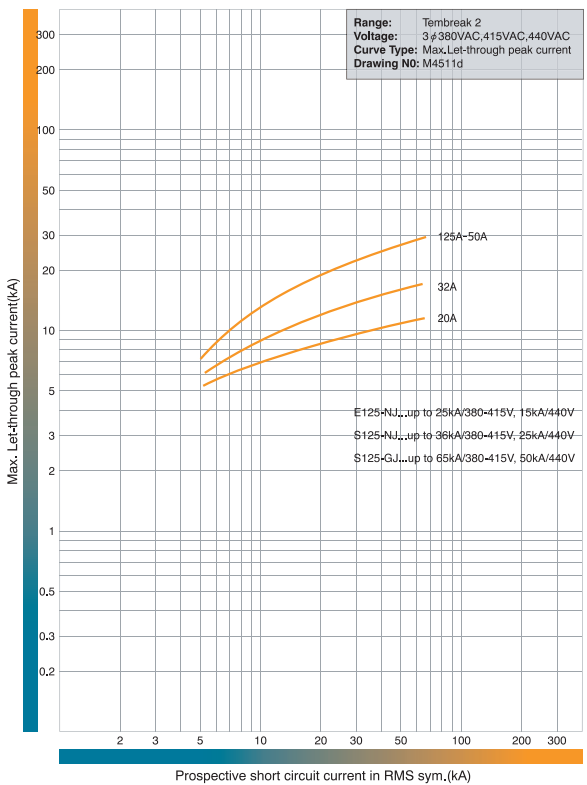

S125-NJ, S125-GJ. 690V AC.

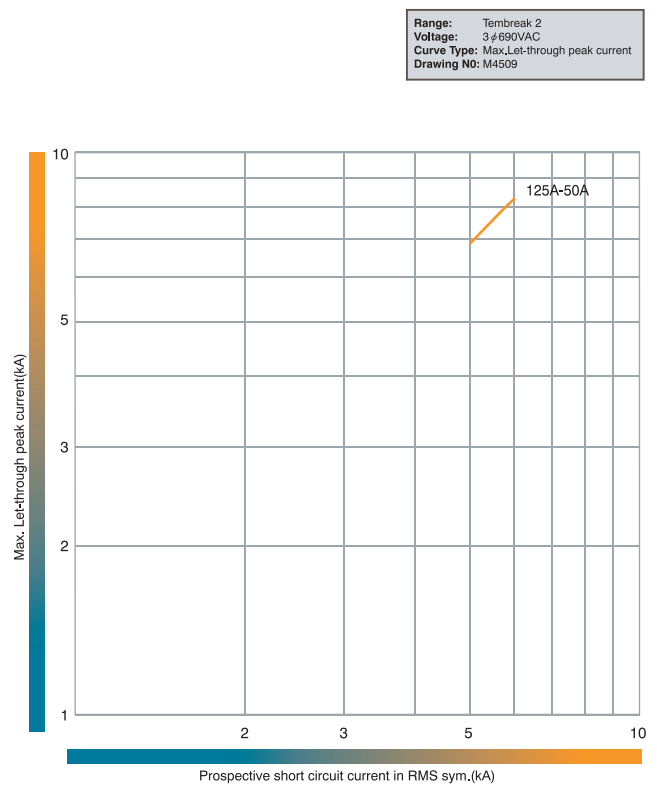

OPERATING CHARACTERISTICS

LET-THROUGH PEAK CURRENT CHARACTERISTICS

H125-NJ, L125-NJ. 440V AC.

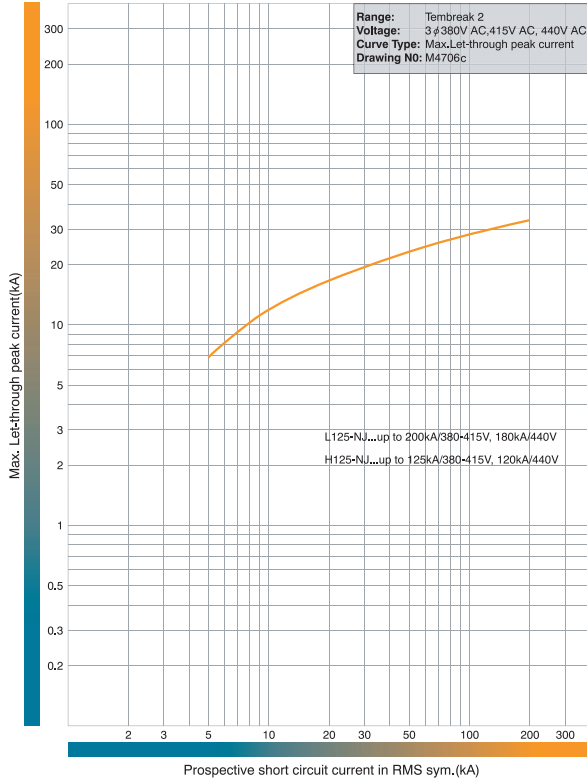

H125-NJ, L125-NJ. 690V AC.

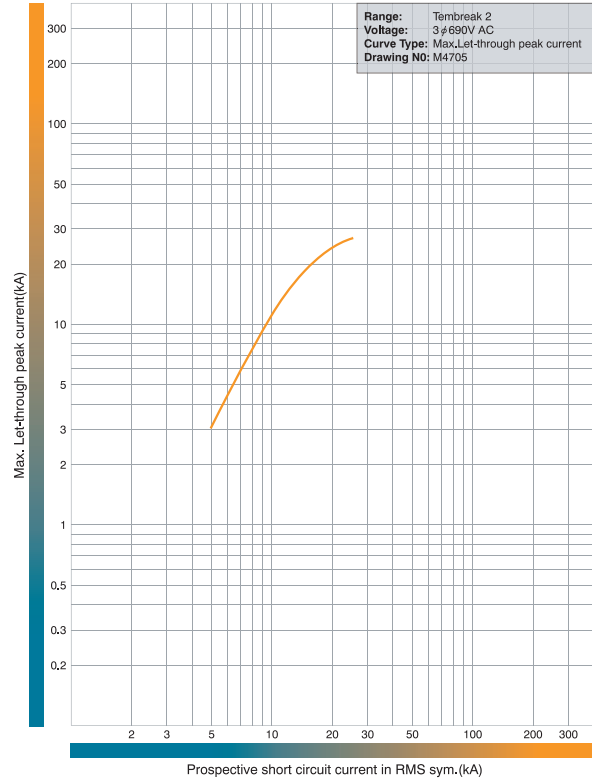

SECTION 3

S160-NJ, S160-GJ, E250-NJ, S250-NJ, S250-GJ. 440V AC.

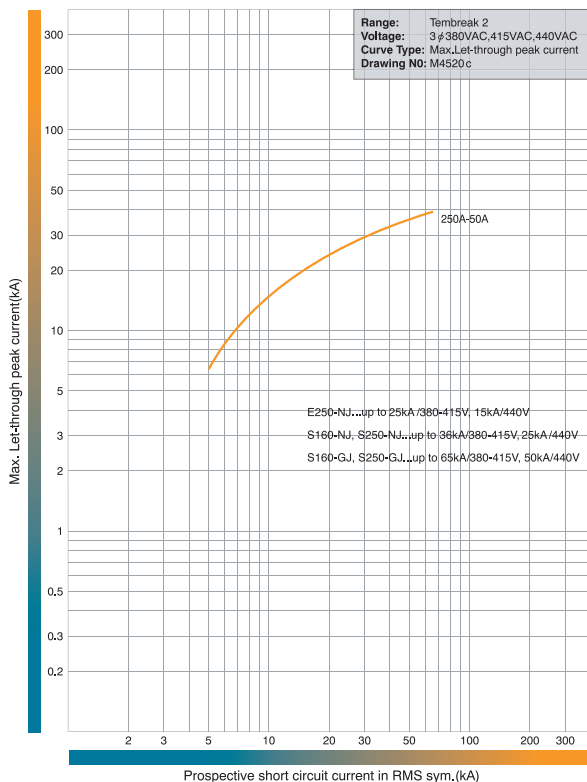

S160-NJ, S160-GJ, S250-NJ, S250-GJ. 690V AC.

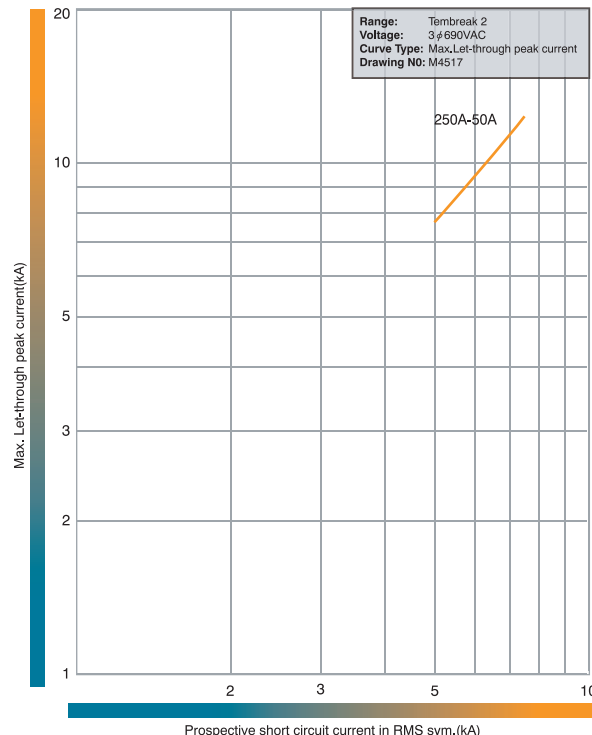

OPERATING CHARACTERISTICS

LET-THROUGH PEAK CURRENT CHARACTERISTICS

H160-NJ, L160-NJ, S250-NE, S250-GE, S250-PE,
H250-NJ, H250-NE, L250-NJ. 440V AC.

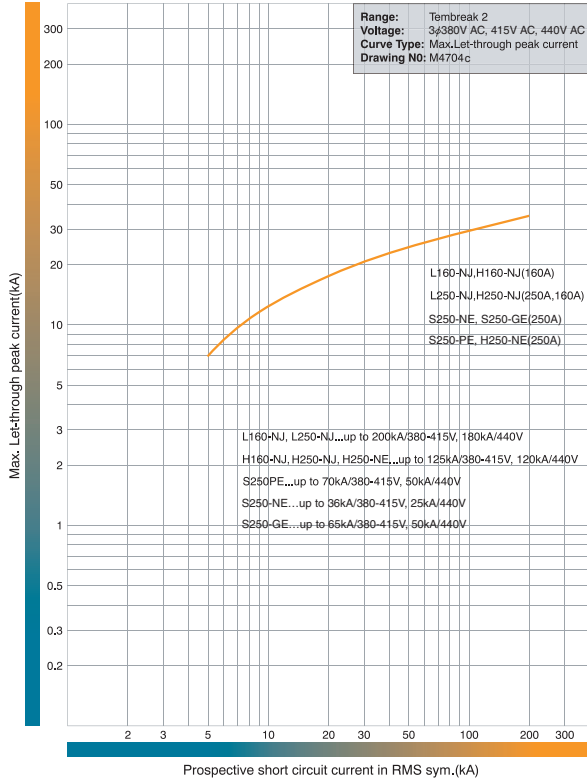

H160-NJ, L160-NJ, S250-NE, S250-GE, S250-PE,
H250-NJ, H250-NE, L250-NJ. 690V AC.

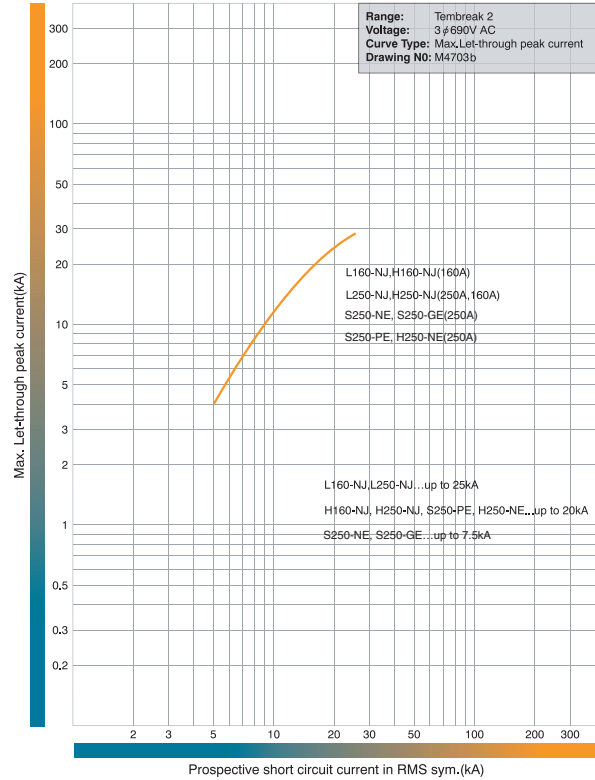

E400-NJ, S400-CJ, S400-NJ, S400-NE, S400-GJ,
S400-GE, S400-PJ, S400-PE. 415V AC.

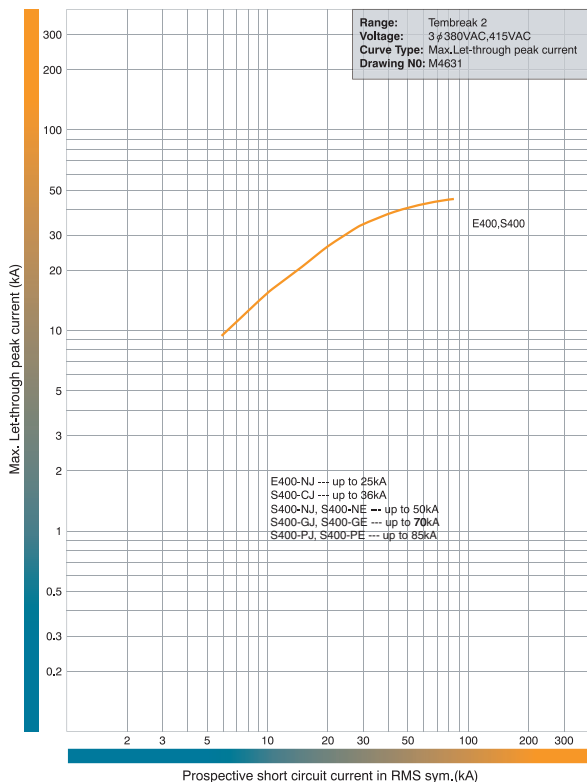

S400-CJ, S400-NJ, S400-NE, S400-GJ,
S400-GE, S400-PJ, S400-PE. 690V AC.

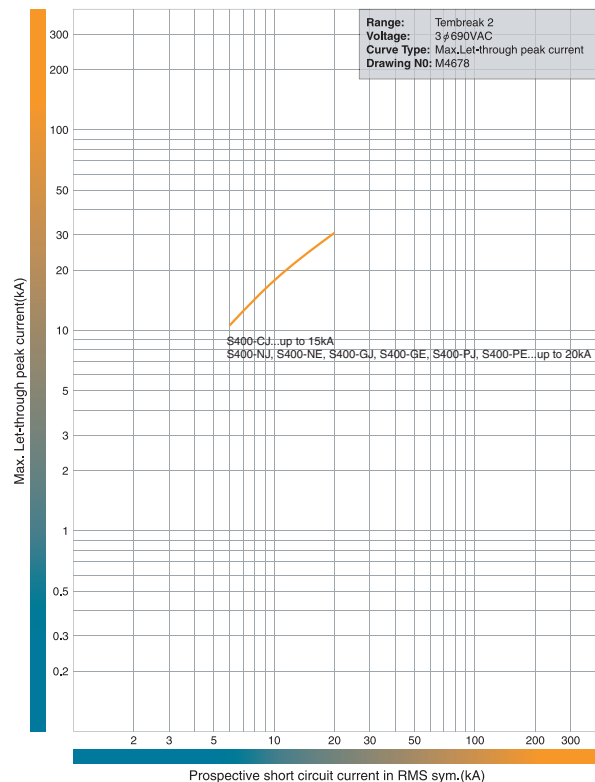

OPERATING CHARACTERISTICS

LET-THROUGH PEAK CURRENT CHARACTERISTICS

H400-NE, L400-NE. 415V AC.

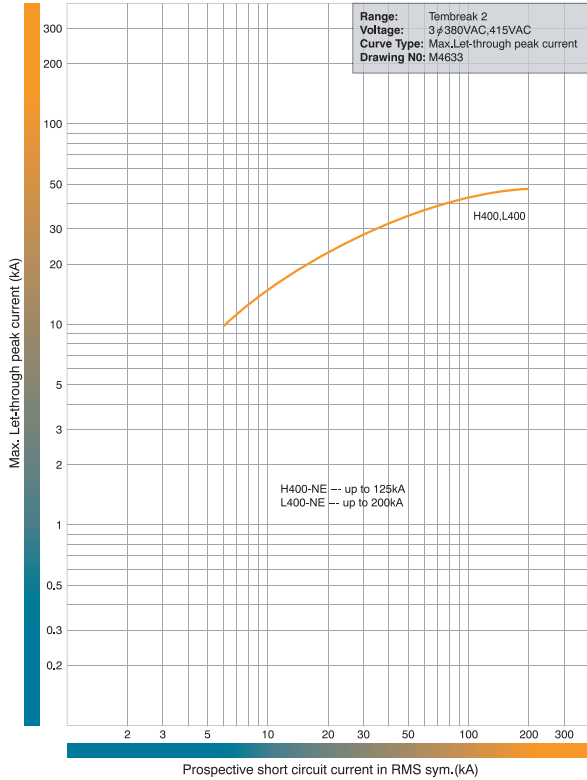

E630-NE, S630-CE, S630-GE. 415V AC.

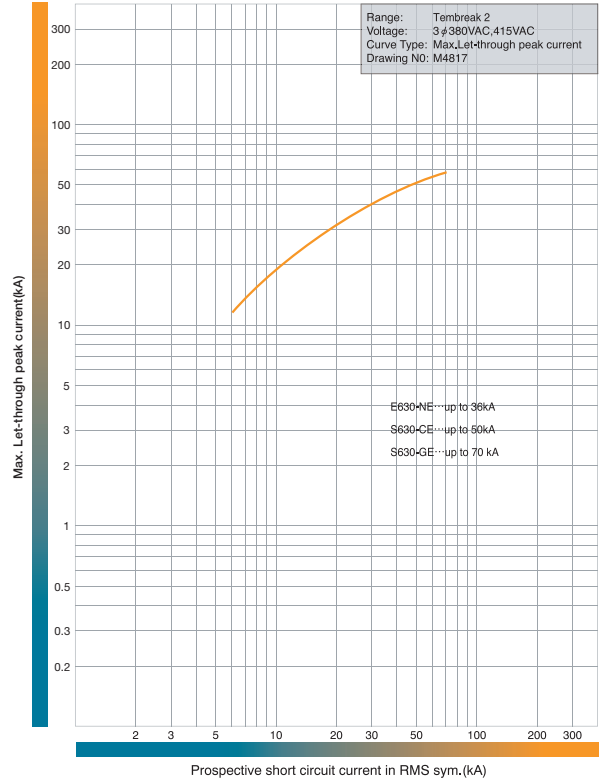

E630-NE, S630-CE, S630-GE. 690V AC.

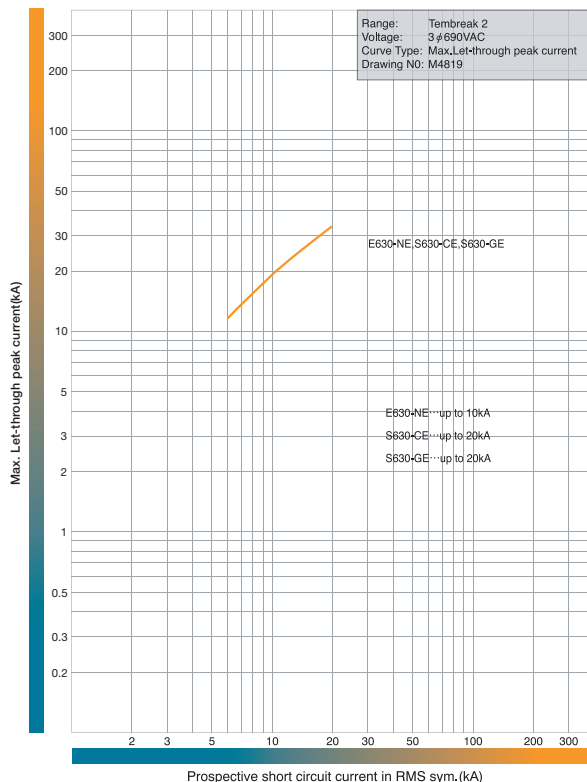

S800-CJ, S800-NJ, S800-RJ. 415V AC.

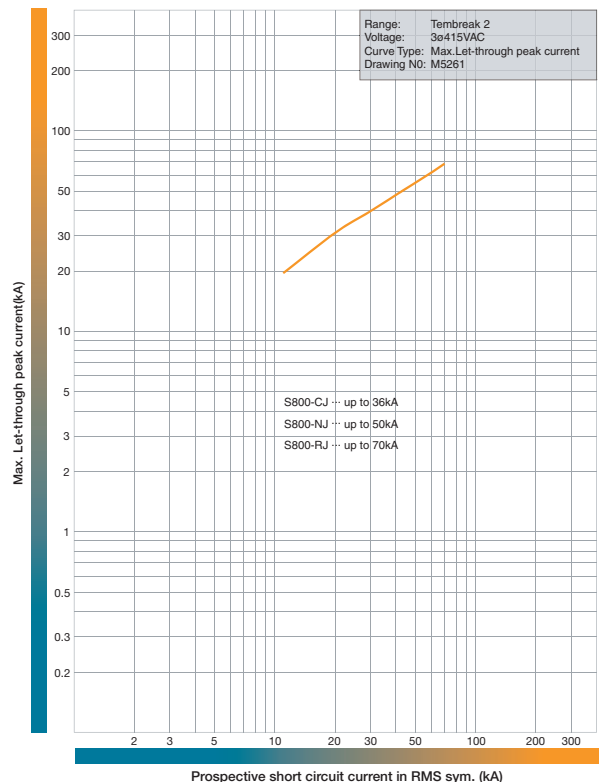

OPERATING CHARACTERISTICS

LET-THROUGH PEAK CURRENT CHARACTERISTICS

S800-NJ, S800-RJ. 690V AC.

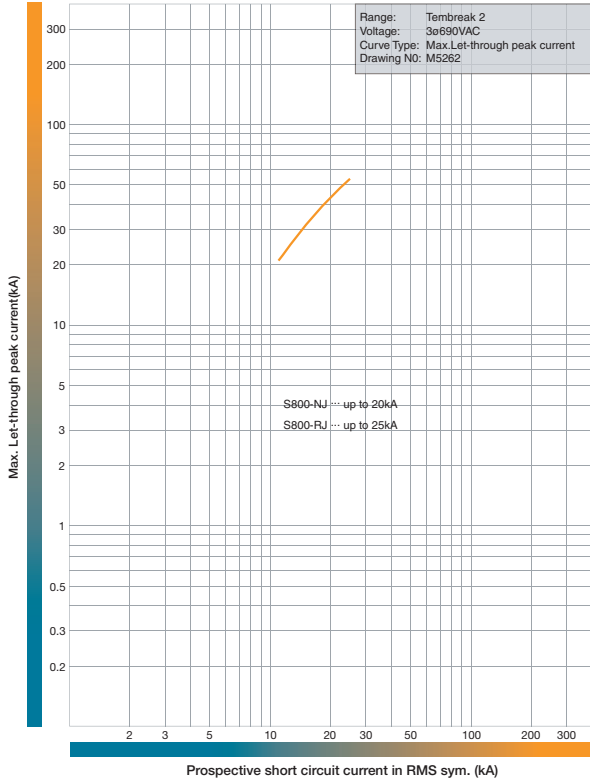

S800-NE, S800-RE. 415V AC.

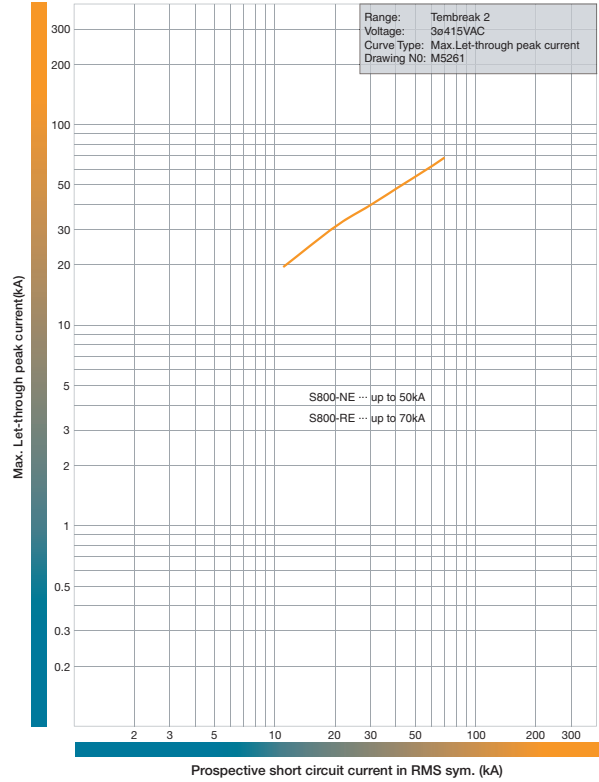

S800-NE, S800-RE. 690V AC.

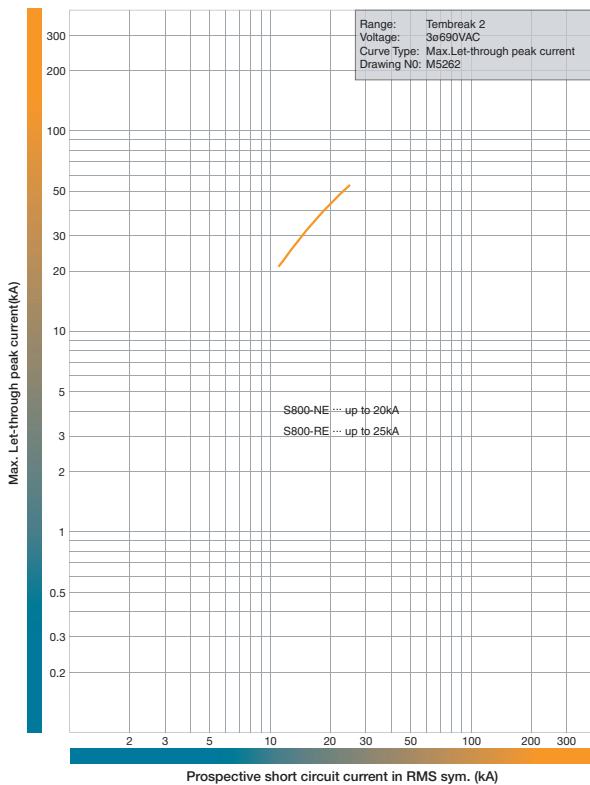

H800-NE, L800-NE. 415V AC.

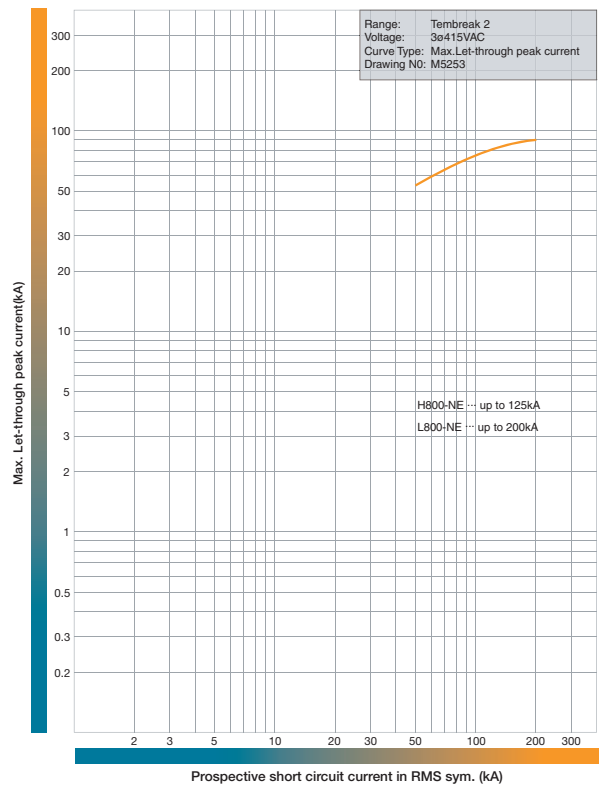

OPERATING CHARACTERISTICS

LET-THROUGH PEAK CURRENT CHARACTERISTICS

H800-NE, L800-NE. 690V AC.

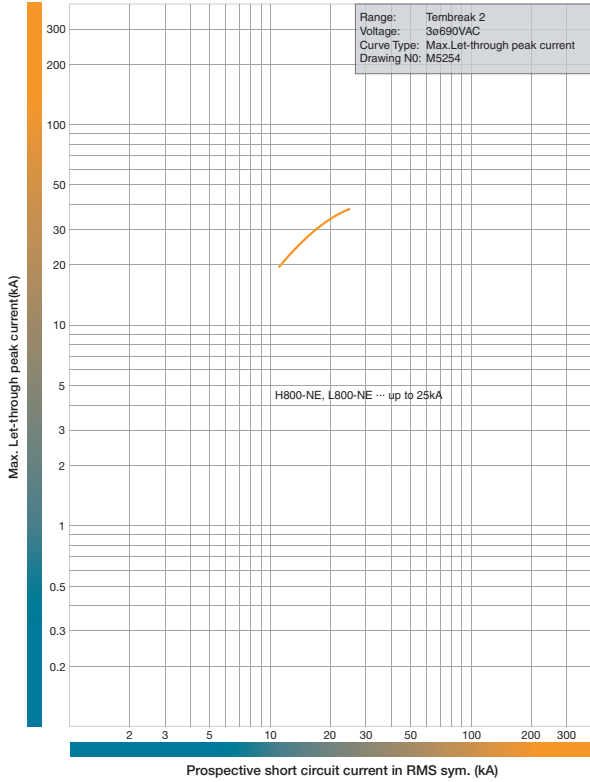

S1000-SE, S1000-NE. 415V AC.

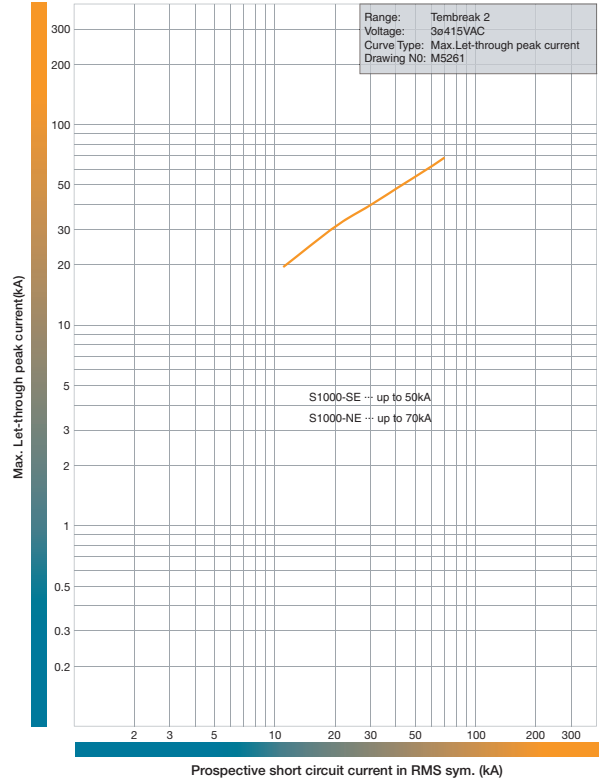

S1000-SE, S1000-NE. 690V AC.

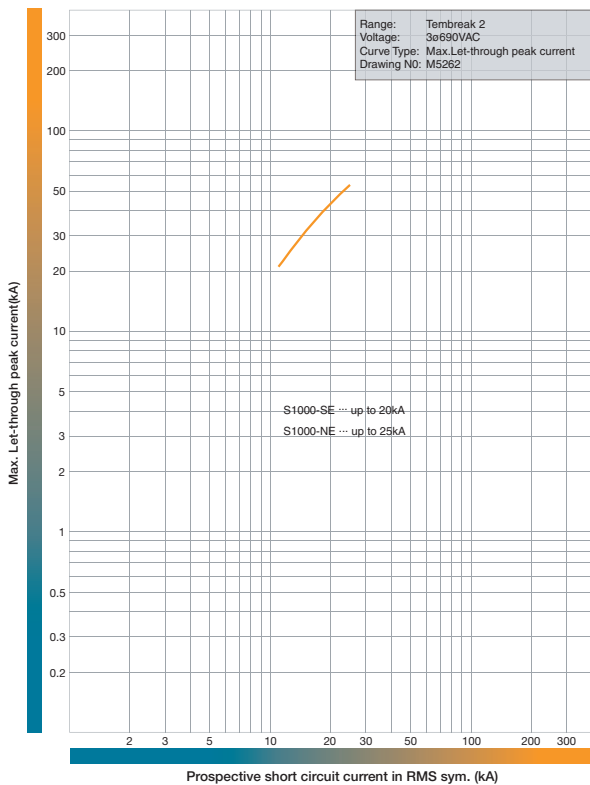

S1250-SE, S1250-NE, S1250-GE. 415V AC.

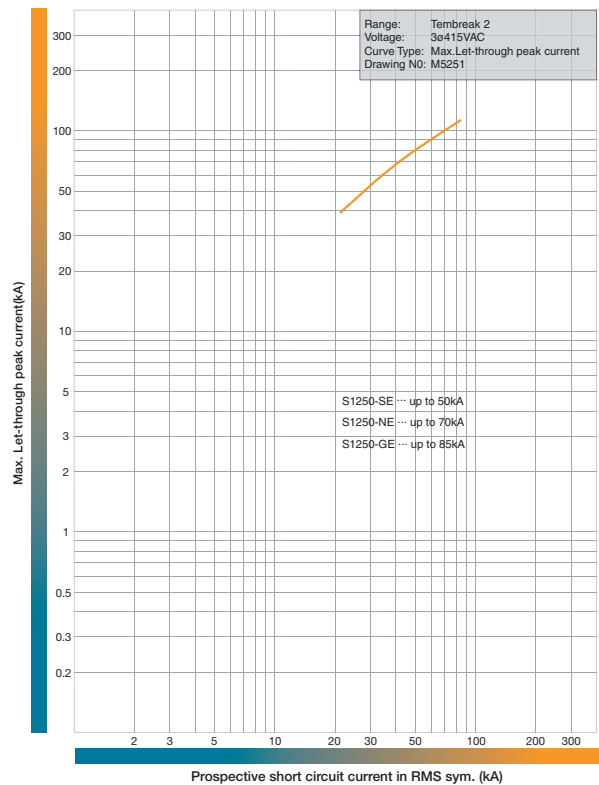

OPERATING CHARACTERISTICS

LET-THROUGH PEAK CURRENT CHARACTERISTICS

S1250-SE, S1250-NE, S1250-GE. 690V AC.

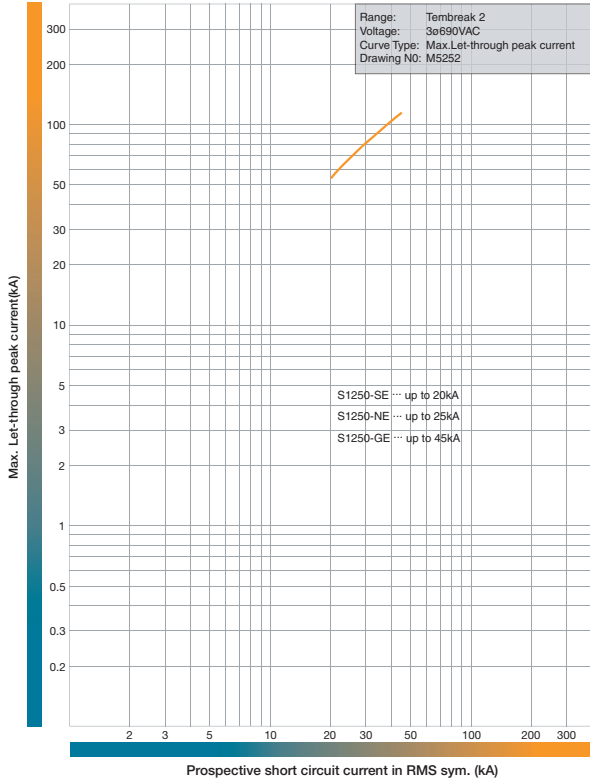

S1600-SE, S1600-NE. 415V AC.

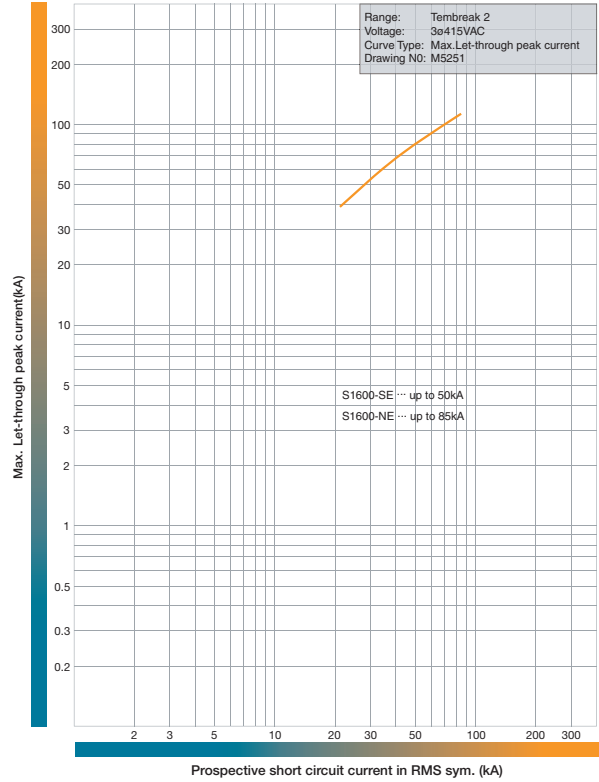

S1600-SE, S1600-NE. 690V AC.

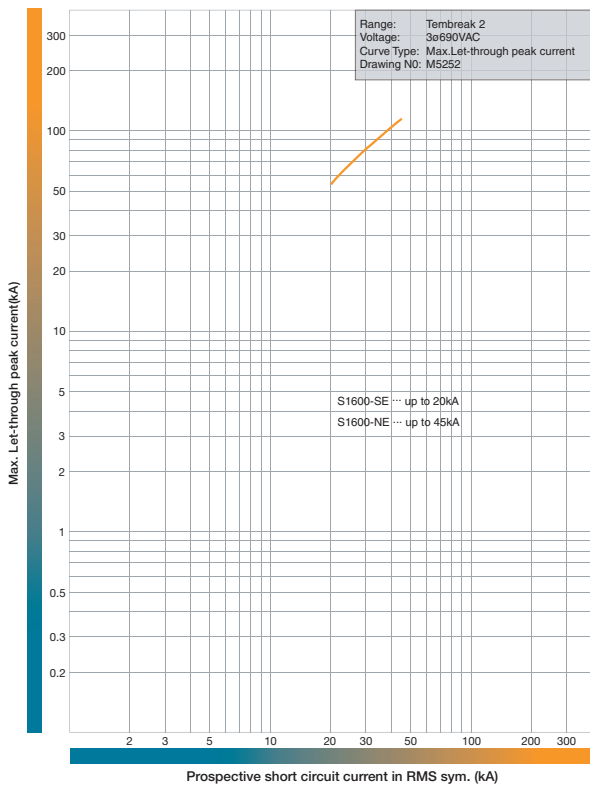

OPERATING CHARACTERISTICS

LET-THROUGH ENERGY CHARACTERISTICS

S125-NF, 240V AC.

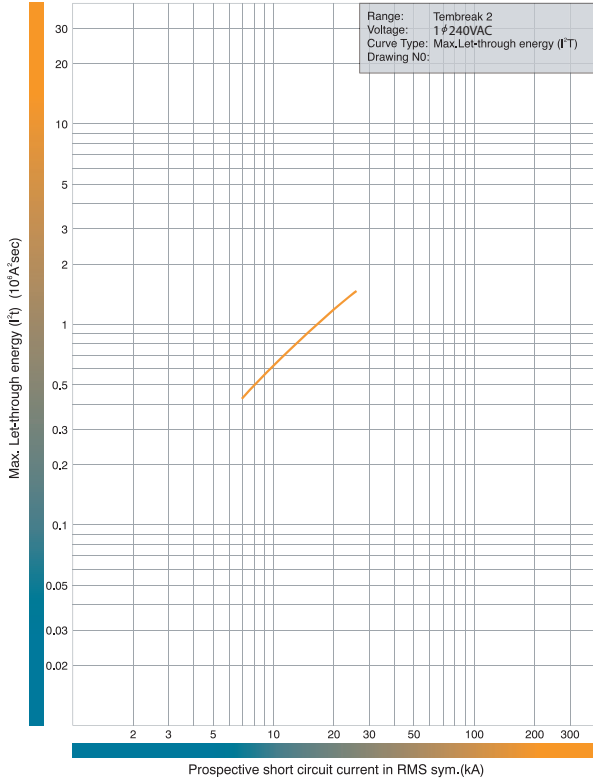

S160-NF, 240V AC.

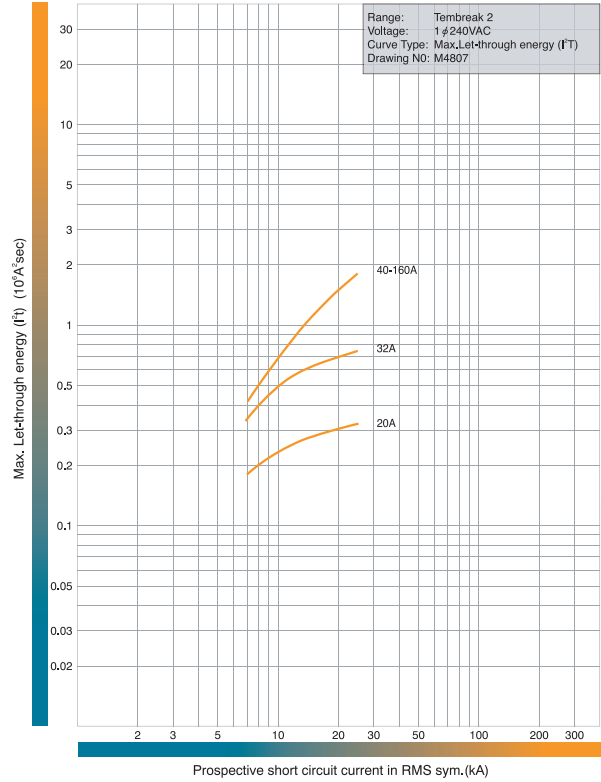

E125-NJ, S125-NJ, S125-GJ. 440V AC.

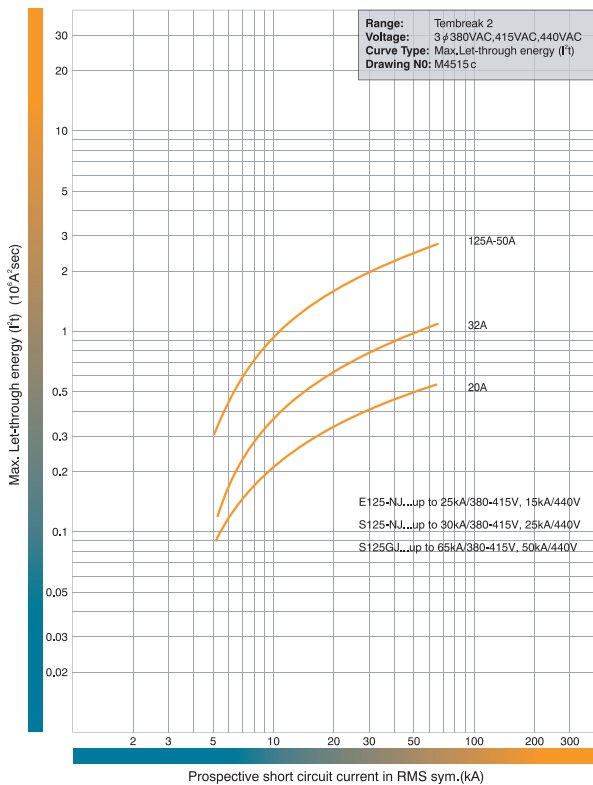

S125-NJ, S125-GJ. 690V AC.

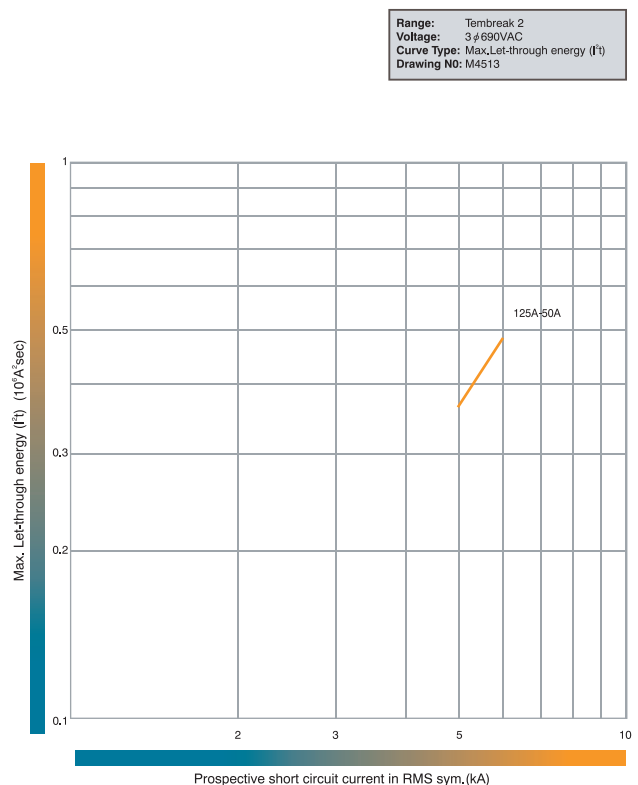

OPERATING CHARACTERISTICS

LET-THROUGH ENERGY CHARACTERISTICS

H125-NJ, L125-NJ. 440V AC.

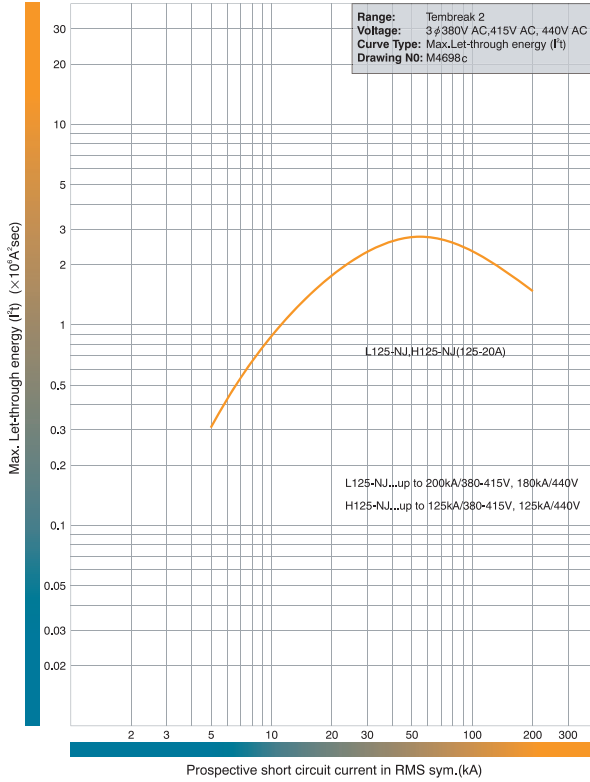

H125-NJ, L125-NJ. 690V AC.

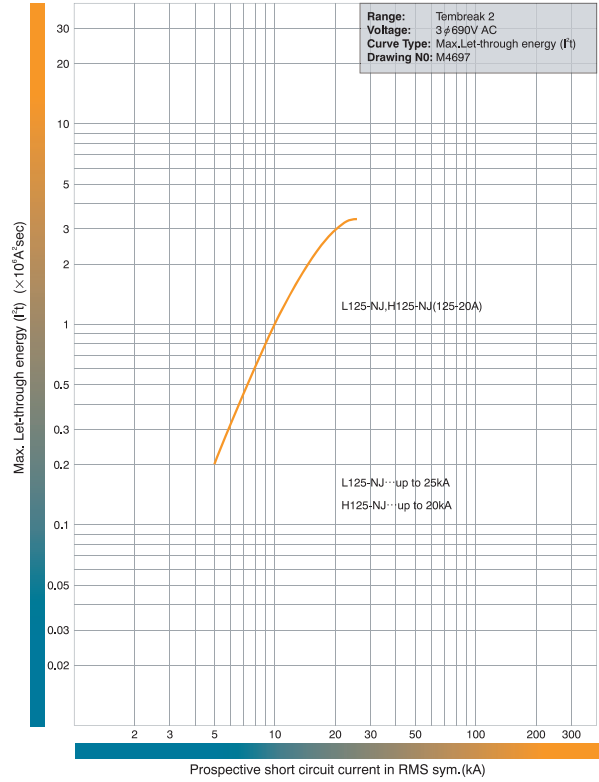

S160-NJ, S160-GJ, E250-NJ, S250-NJ, S250-GJ. 440V AC.

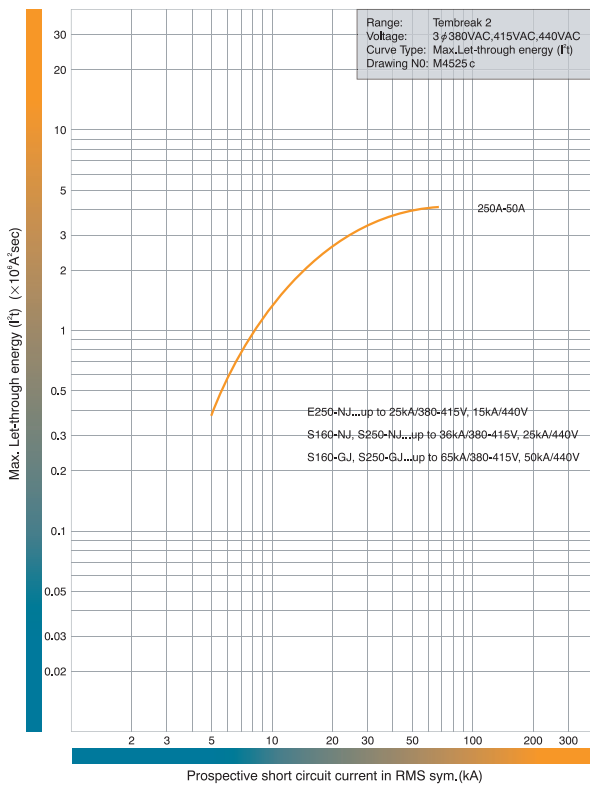

S160-NJ, S160-GJ, S250-NJ, S250-GJ. 690V AC.

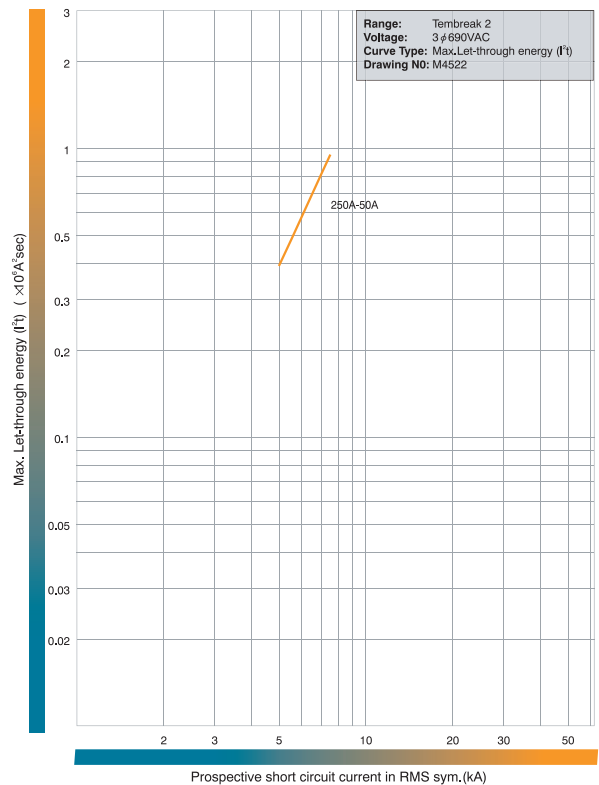

OPERATING CHARACTERISTICS

LET-THROUGH ENERGY CHARACTERISTICS

H160-NJ, L160-NJ, S250-NE, S250-GE, S250-PE, H250-NE, H250-NJ, L250-NJ. 440V AC.

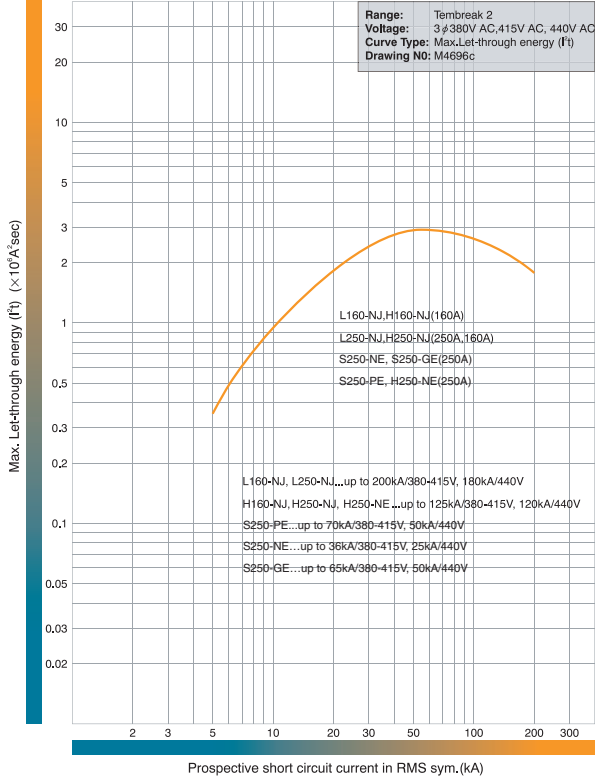

H160-NJ, L160-NJ, S250-NE, S250-GE, S250-PE, H250-NE, H250-NJ, L250-NJ. 690V AC.

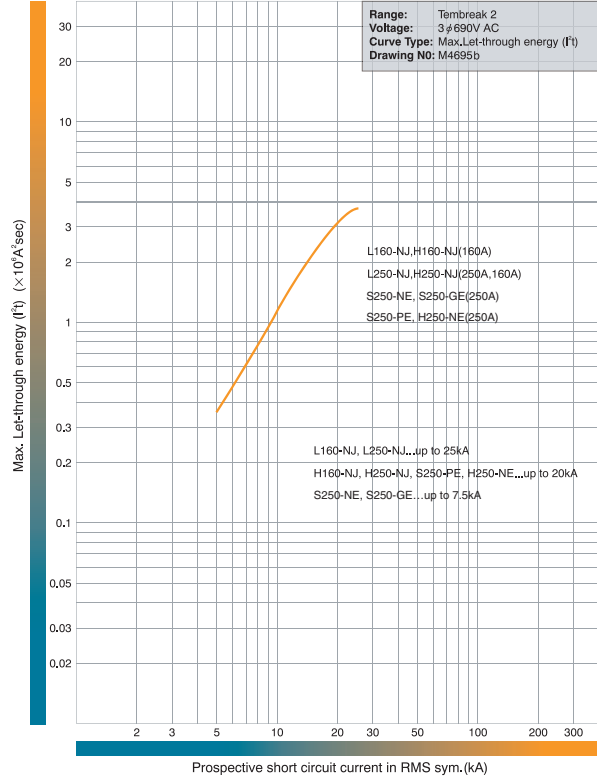

E400-NJ, S400-CJ, S400-NJ, S400-NE, S400-GJ, S400-GE, S400-PJ, S400-PE. 415V AC.

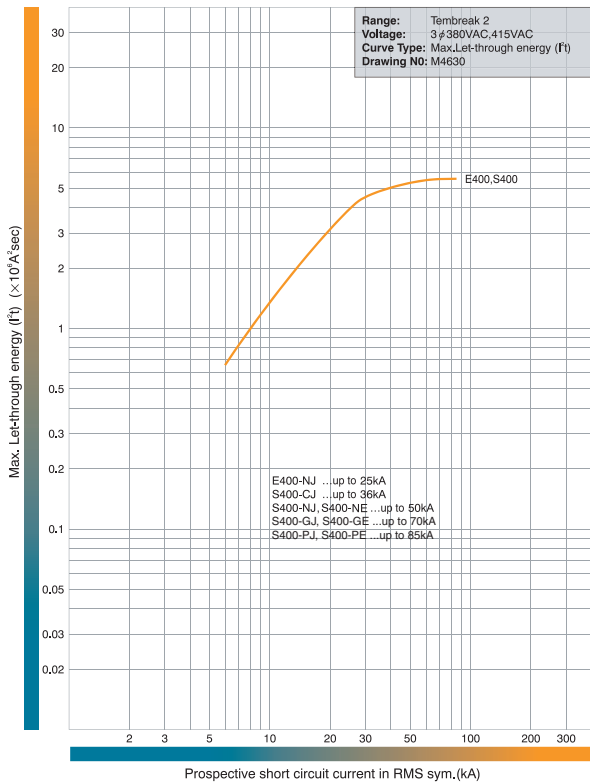

S400-CJ, S400-NJ, S400-NE, S400-GJ, S400-GE, S400-PJ, S400-PE. 690V AC.

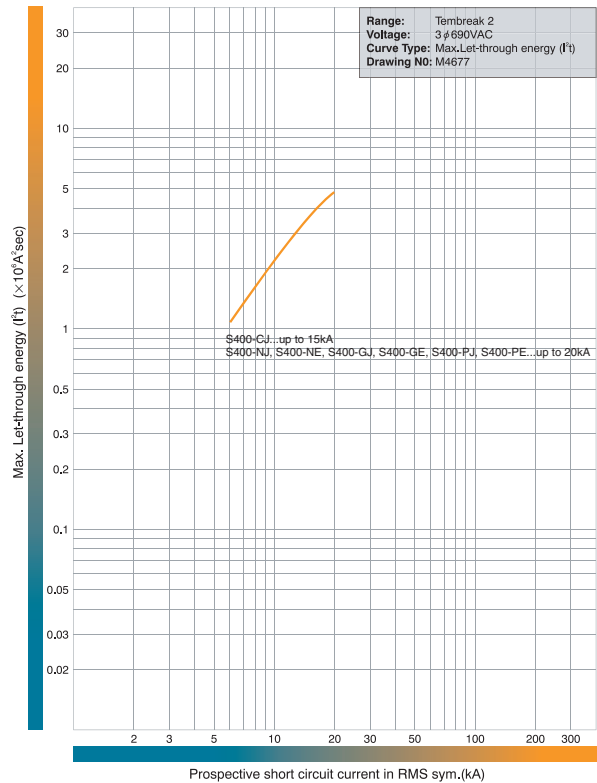

OPERATING CHARACTERISTICS

LET-THROUGH ENERGY CHARACTERISTICS

H400-NE, L400-NE. 415V AC.

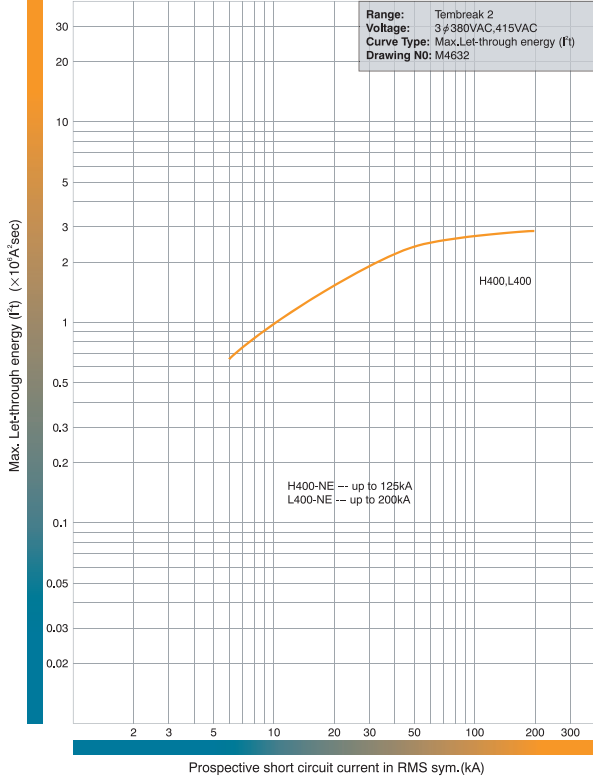

E630-NE, S630-CE, S630-GE. 415V AC.

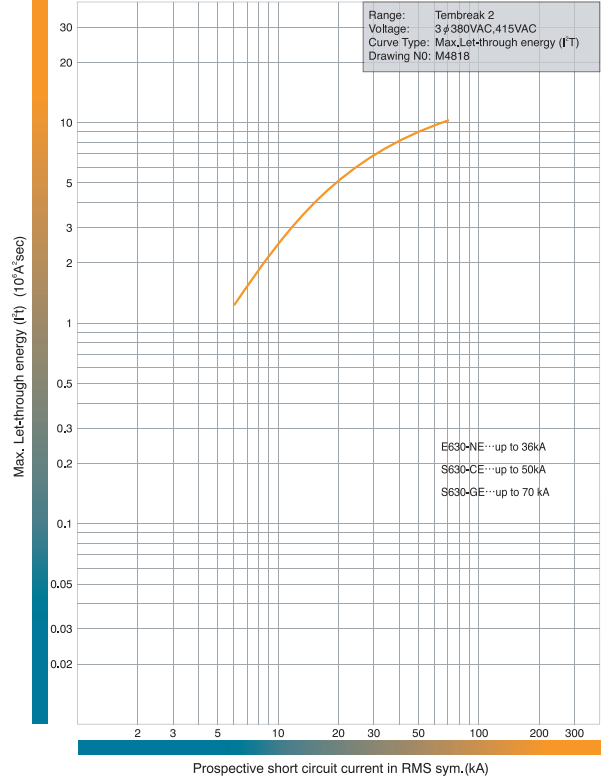

E630-NE, S630-CE, S630-GE. 690V AC.

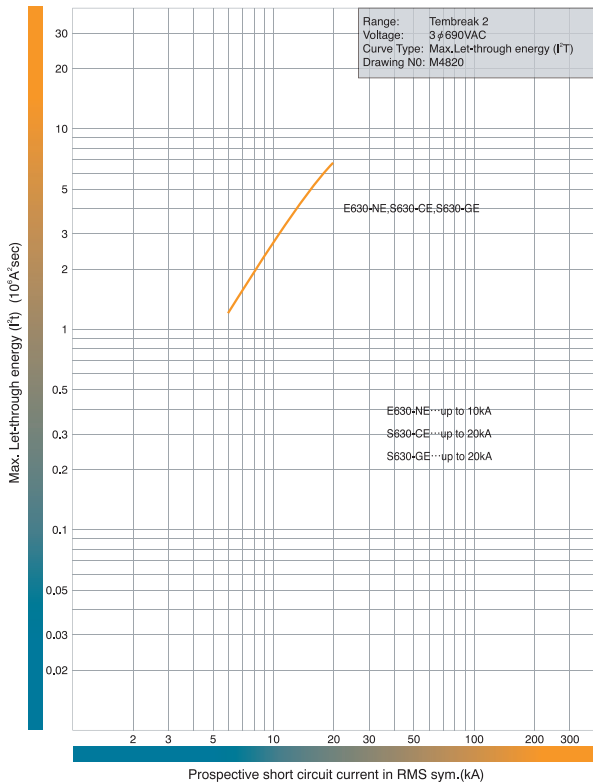

S800-CJ, S800-NJ, S800-RJ. 415V AC.

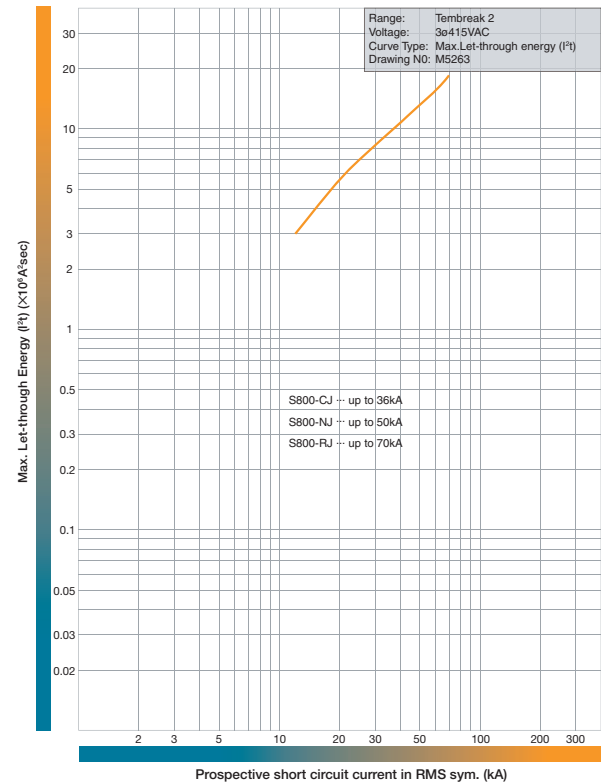

OPERATING CHARACTERISTICS

LET-THROUGH ENERGY CHARACTERISTICS

S800-NJ, S800-RJ. 690V AC.

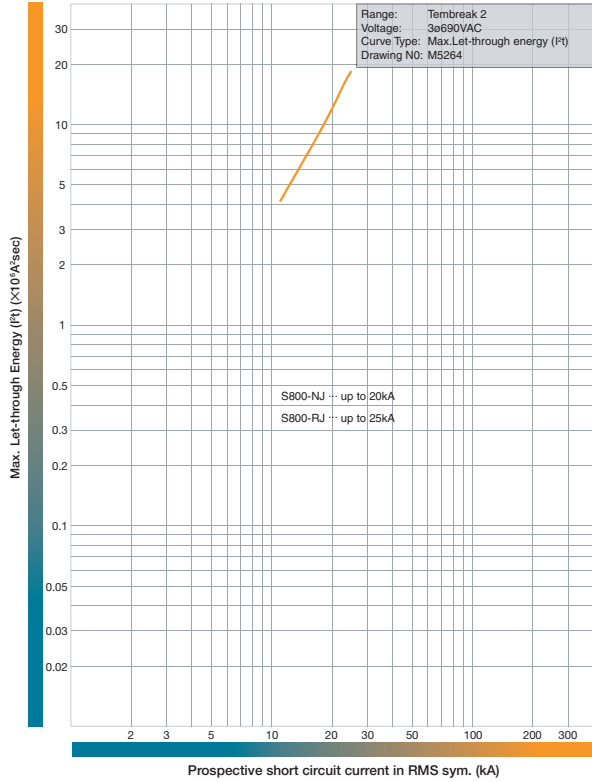

S800-NE, S800-RE. 415V AC.

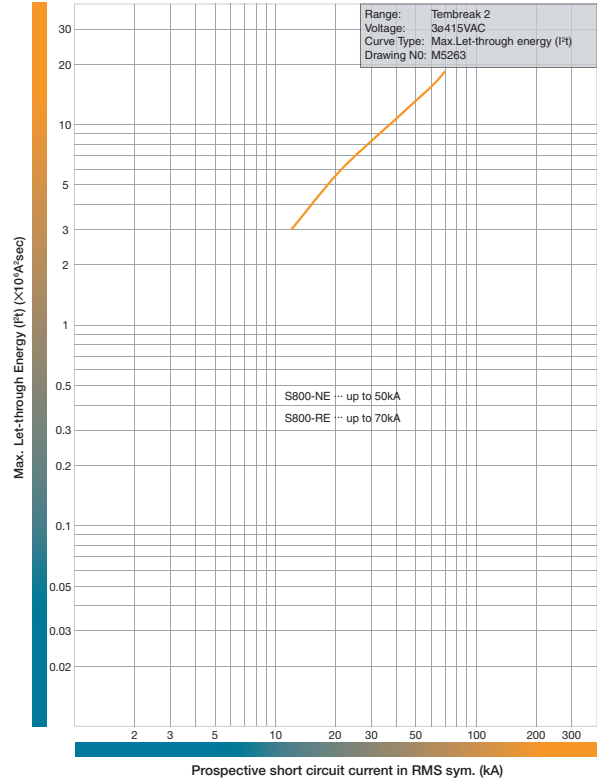

S800-NE, S800-RE. 690V AC.

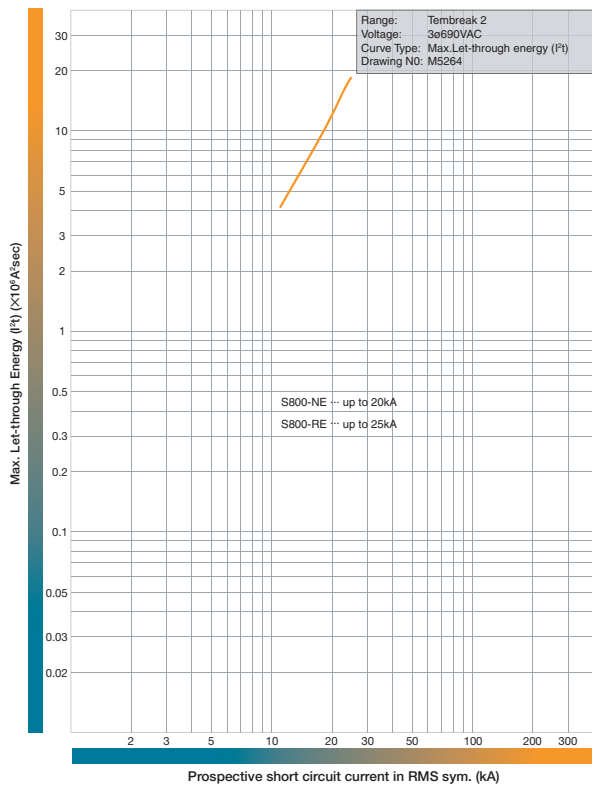

H800-NE, L800-NE. 415V AC.

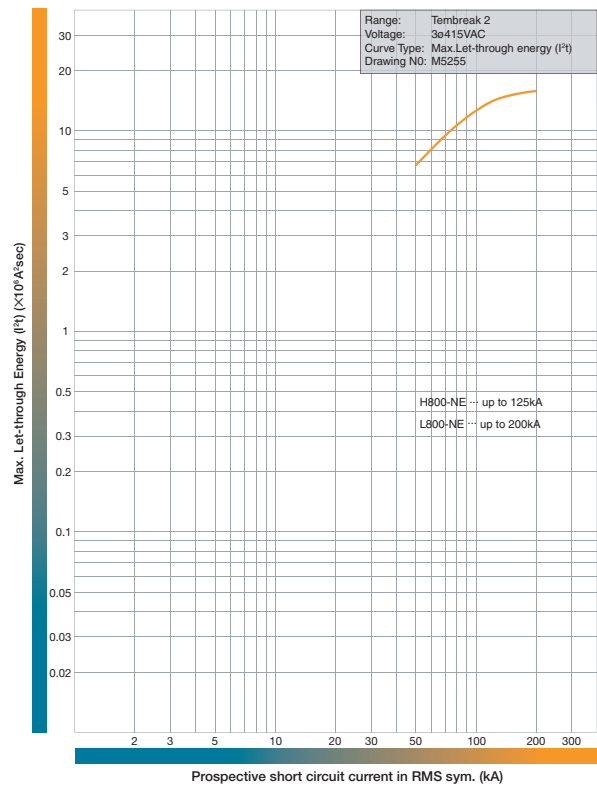

OPERATING CHARACTERISTICS

LET-THROUGH ENERGY CHARACTERISTICS

H800-NE, L800-NE. 690V AC.

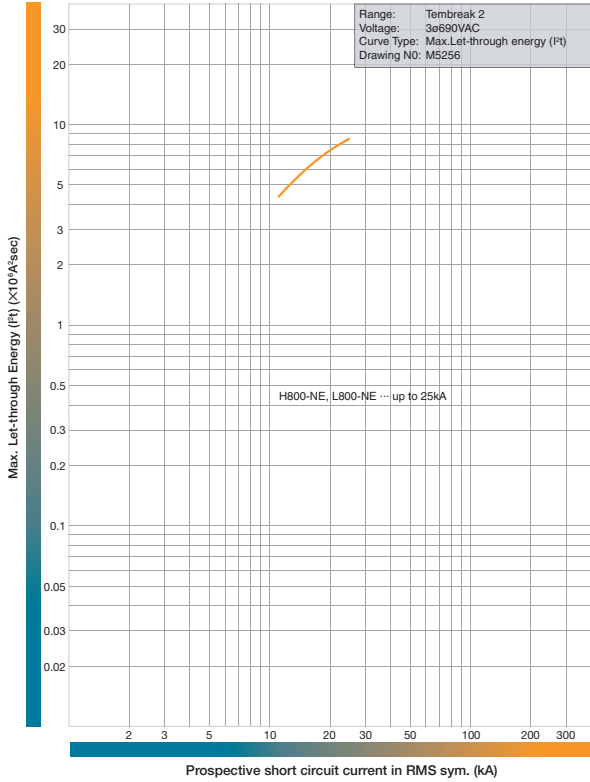

S1000-SE, S1000-NE. 415V AC.

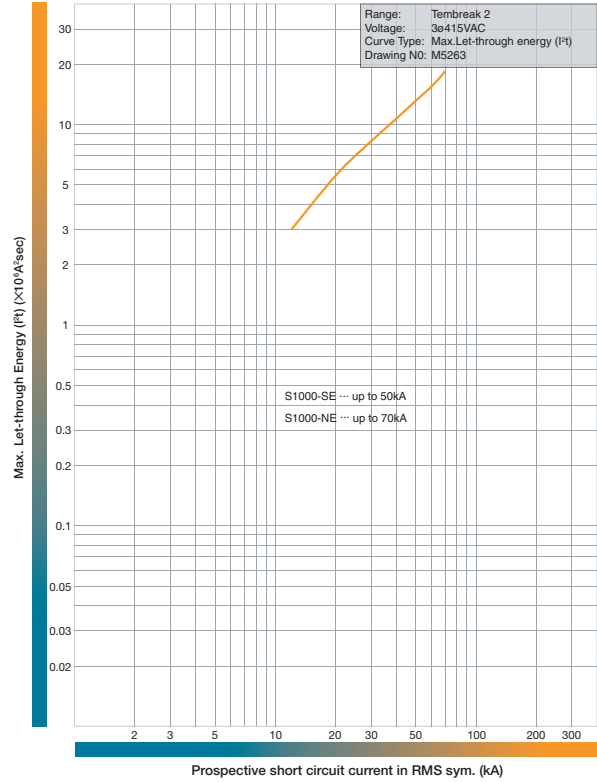

S1000-SE, S1000-NE. 690V AC.

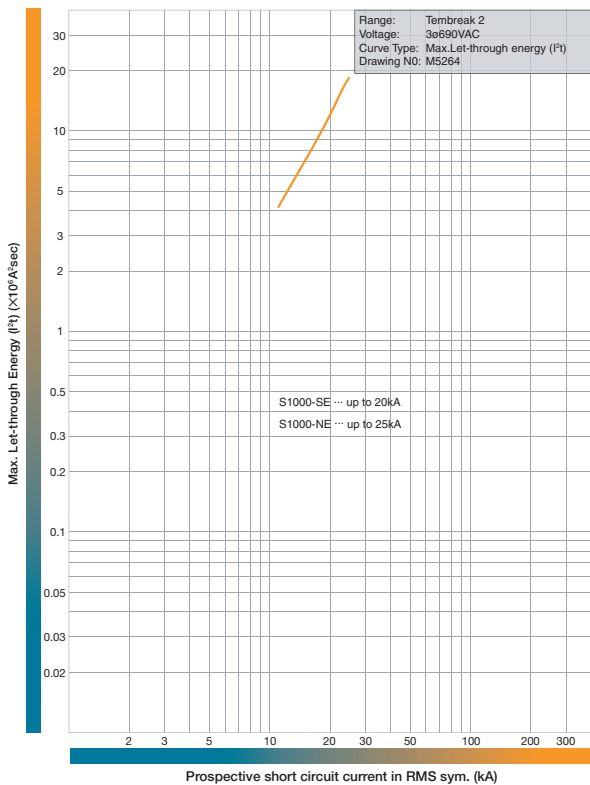

S1250-SE, S1250-NE, S1250-GE. 415V AC.

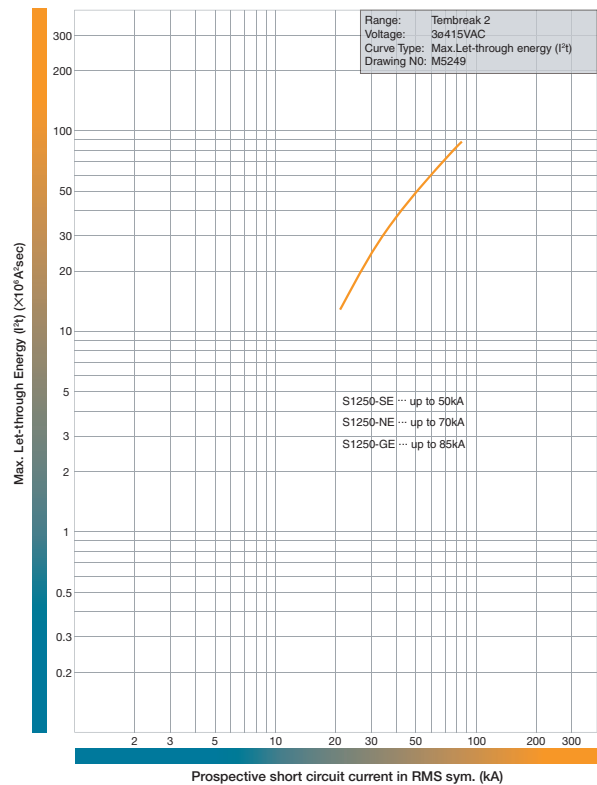

OPERATING CHARACTERISTICS

LET-THROUGH ENERGY CHARACTERISTICS

S1250-SE, S1250-NE, S1250-GE. 690V AC.

S1600-SE, S1600-NE. 415V AC.

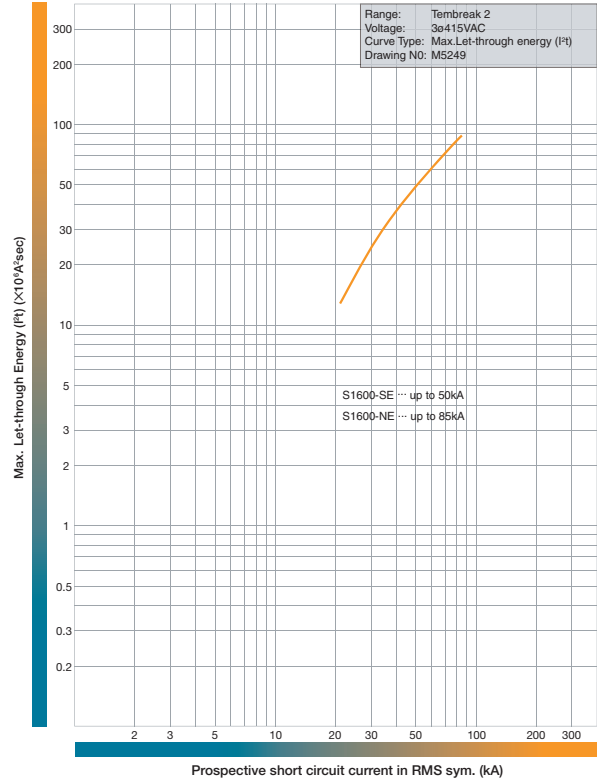
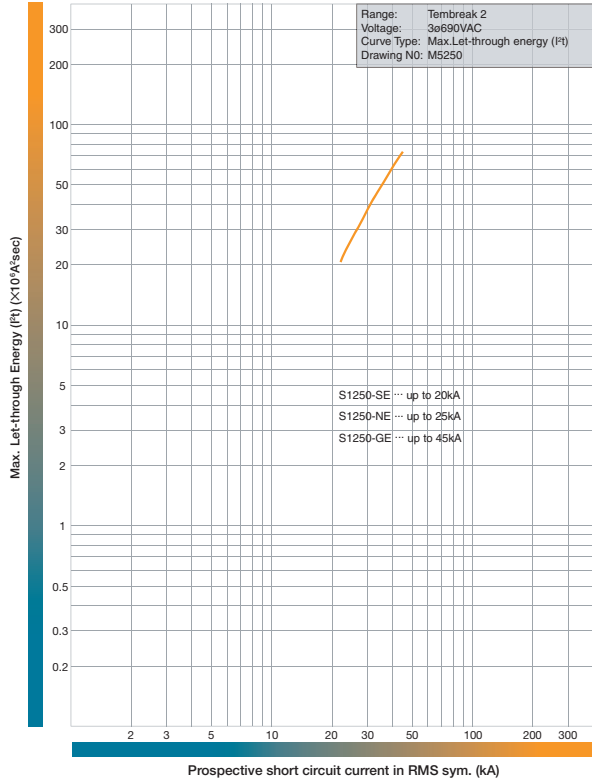

S1600-SE, S1600-NE. 690V AC.

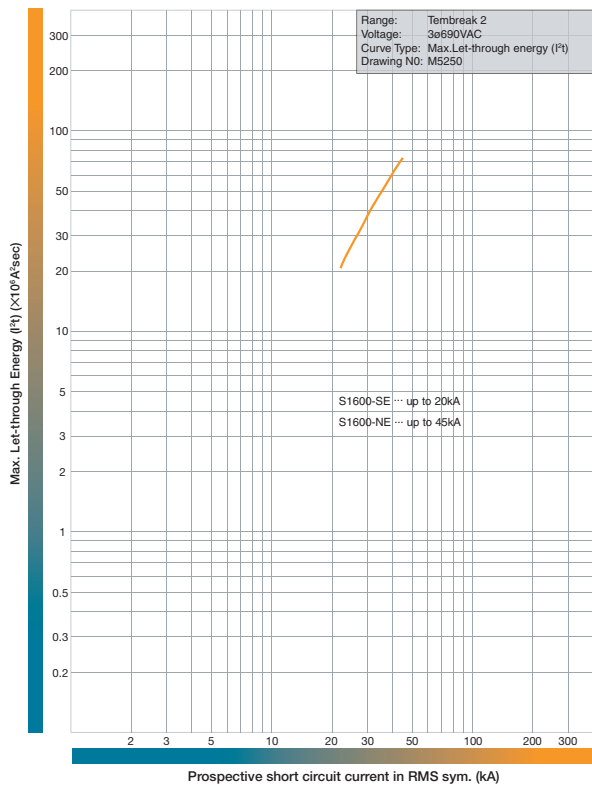

SYMMETRICAL DOOR CUTOUT PATTERNS



Door cutout patterns for handles are symmetrical, even when breakers are mounted in opposite directions.

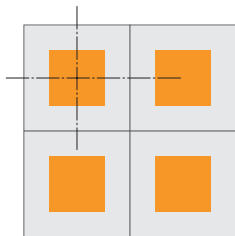

Using TemBreak 2 Operating Handles

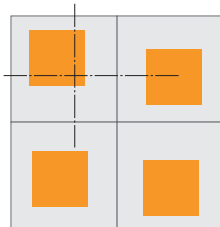

Using other MCCB Operating Handles



TEMBREAK 2 MOULDED CASE CIRCUIT BREAKERS 16A TO 1600A

1.	Welcome to TemBreak 2	
2.	Ratings and Specifications	
3.	Operating Characteristics	
4.	Application Data	
	• What is Discrimination?	69
	• How to Read the Discrimination Tables	70
	• Discrimination Tables	71
	• What is Cascading?	74
	• How to Read the Cascade Tables	75
	• Cascade Tables	76
5.	Accessories	
6.	Installation	
7.	Dimensions	

APPLICATION DATA

DISCRIMINATION

WHAT IS DISCRIMINATION?

Discrimination, also called selectivity, is the co-ordination of protective devices such that a fault is cleared by the protective device installed immediately upstream of the fault, and by that device alone.

Total discrimination

Discrimination is said to be total if the downstream circuit breaker opens and the upstream circuit breaker remains closed. This ensures maximum availability of the system.

Partial discrimination

Discrimination is partial if the above condition is not fulfilled up to the prospective short-circuit current, but to a lesser value, termed the selectivity limit current (I_s).

Above this value both circuit breakers could open, resulting in loss of selectivity.

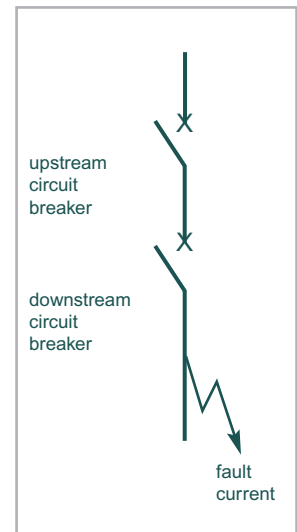

HOW TO READ THE DISCRIMINATION TABLES

Boxes containing the letter “T” indicate total discrimination between the relevant upstream and downstream circuit-breakers. Total discrimination applies for all fault levels up to the breaking capacity of the upstream or the downstream circuit breaker, whichever is the lesser.

For the other boxes, discrimination is either partial or there is no discrimination.

If discrimination is partial then the value of the selectivity limit current, I_s , is shown in the box.

Worked Examples

Q (1) A main switchboard requires a 1600A ACB feeding a 400A MCCB. The fault level is 70kA. What combination of protective devices would provide total discrimination?

A (1) A TemPower2 ACB AR216S feeding a TemBreak2 S400-GJ would provide total discrimination up to 70kA. See page 71

Note: Discrimination would be total whether the TemPower 2 ACB had an integral or external protection relay because $I_{cw} (I_s) = I_{cs}$.

Most other ACBs have $I_{cw} (I_s) < I_{cs}$.

HOW TO READ THE DISCRIMINATION TABLES

Q (2) A Sub distribution board requires a 630A MCCB feeding a 250A MCCB. The fault level is 65kA. What combination of protective devices would provide total discrimination?

A (2) Using a TemBreak 2 S630-GE MCCB feeding a TemBreak 2 S250-GJ would provide total discrimination up to 65kA. See page 73

Q (3) A final distribution board contains a 125A MCCB incomer feeding a 32A Type B MCB. Is discrimination between these devices possible?

A (3) A TemBreak 2 MCCB type S160-NJ/125A feeding a TD3 DIN type MCB would provide total discrimination. See page 72

Alternatively ANY OTHER MCB can be used provided it has energy limiting ability of class 3 in accordance with EN 60898.

APPLICATION DATA

DISCRIMINATION TABLES

Upstream: TemPower 2 ACB with or without Integral Protection Relay.

Downstream: TemBreak 2 MCCB.

		Upstream ACB																				
Frame	Model	Breaking Capacity	800A			1250A			1600A			2000A			2500A		3200A		4000A	5000A	6300A	
			AR208S	AR212S	AR212H	AR216S	AR216H	AR316H	AR220S	AR220H	AR320H	AR325S	AR325H	AR332S	AR332H	AR440SB	AR650S	AR663S	AR663H			
			65kA	65kA	80kA	65kA	80kA	100kA	65kA	80kA	100A	85kA	100kA	85kA	100kA	100kA	120kA	120kA	120kA	135kA		
125A	E125NJ	25kA	T	T	T	T	T	T	T	T	T	T	T	T	T	T	T	T	T	T		
	S125NJ	36kA	T	T	T	T	T	T	T	T	T	T	T	T	T	T	T	T	T	T		
	S125GJ	65kA	T	T	T	T	T	T	T	T	T	T	T	T	T	T	T	T	T	T		
	H125NJ	125kA	T	T	T	T	T	T	T	T	T	T	T	T	T	T	T	T	T	T		
	L125NJ	200kA	T	T	T	T	T	T	T	T	T	T	T	T	T	T	T	T	T	T		
160A/ 250A	S160NJ	36kA	T	T	T	T	T	T	T	T	T	T	T	T	T	T	T	T	T	T		
	S160GJ	65kA	T	T	T	T	T	T	T	T	T	T	T	T	T	T	T	T	T	T		
	E250NJ	25kA	T	T	T	T	T	T	T	T	T	T	T	T	T	T	T	T	T	T		
	S250NJ	36kA	T	T	T	T	T	T	T	T	T	T	T	T	T	T	T	T	T	T		
	S250GJ	65kA	T	T	T	T	T	T	T	T	T	T	T	T	T	T	T	T	T	T		
	S250PE	70kA	T	T	T	T	T	T	T	T	T	T	T	T	T	T	T	T	T	T		
	H250NJ	125kA	T	T	T	T	T	T	T	T	T	T	T	T	T	T	T	T	T	T		
	L250NJ	200kA	T	T	T	T	T	T	T	T	T	T	T	T	T	T	T	T	T	T		
	400A/ 630A	E400NJ	25kA	T	T	T	T	T	T	T	T	T	T	T	T	T	T	T	T	T	T	
S400CJ		36kA	T	T	T	T	T	T	T	T	T	T	T	T	T	T	T	T	T	T		
S400NJ		50kA	T	T	T	T	T	T	T	T	T	T	T	T	T	T	T	T	T	T		
S400NE		50kA	T	T	T	T	T	T	T	T	T	T	T	T	T	T	T	T	T	T		
S400GJ		70kA	T	T	T	T	T	T	T	T	T	T	T	T	T	T	T	T	T	T		
S400GE		70kA	T	T	T	T	T	T	T	T	T	T	T	T	T	T	T	T	T	T		
S400PJ		85kA	T	T	T	T	T	T	T	T	T	T	T	T	T	T	T	T	T	T		
S400PE		85kA	T	T	T	T	T	T	T	T	T	T	T	T	T	T	T	T	T	T		
H400NE		125kA	T	T	T	T	T	T	T	T	T	T	T	T	T	T	T	T	T	T		
E630NE		36kA	T	T	T	T	T	T	T	T	T	T	T	T	T	T	T	T	T	T		
S630CE		50kA	T	T	T	T	T	T	T	T	T	T	T	T	T	T	T	T	T	T		
S630GE		70kA	T	T	T	T	T	T	T	T	T	T	T	T	T	T	T	T	T	T		
800A		S800-CJ	36kA	T	T	T	T	T	T	T	T	T	T	T	T	T	T	T	T	T	T	
		S800-NJ	50kA	T	T	T	T	T	T	T	T	T	T	T	T	T	T	T	T	T	T	
	S800-RJ	70kA	T	T	T	T	T	T	T	T	T	T	T	T	T	T	T	T	T	T		
	S800-NE	50kA	T	T	T	T	T	T	T	T	T	T	T	T	T	T	T	T	T	T		
	S800-RE	70kA	T	T	T	T	T	T	T	T	T	T	T	T	T	T	T	T	T	T		
	H800-NE	125kA	T	T	T	T	T	T	T	T	T	T	T	T	T	T	T	T	T	T		
	L800-NE	200kA	T	T	T	T	T	T	T	T	T	T	T	T	T	T	T	T	T	T		
	1000A	S1000-SE	50kA	-	T	T	T	T	T	T	T	T	T	T	T	T	T	T	T	T	T	
S1000-NE		70kA	-	T	T	T	T	T	T	T	T	T	T	T	T	T	T	T	T	T		
1250A	S1250-SE	50kA	-	T	T	T	T	T	T	T	T	T	T	T	T	T	T	T	T	T		
	S1250-NE	70kA	-	T	T	T	T	T	T	T	T	T	T	T	T	T	T	T	T	T		
	S1250-GE	100kA	-	T	T	T	T	T	T	T	T	T	T	T	T	T	T	T	T	T		
1600A	S1600-SE	50kA	-	-	-	T	T	T	T	T	T	T	T	T	T	T	T	T	T	T		
	S1600-NE	100kA	-	-	-	T	T	T	T	T	T	T	T	T	T	T	T	T	T	T		

Notes: 1. All ACB's have I_t set at NON, MCR ON.

2. Assuming ACB time settings are greater than MCCB.

3. The above table is in accordance with IEC 60947-2, Annex A.

4. External relay can be used - Contact Terasaki for further details.

5. All values shown at 400V AC.

T= Total Selectivity

APPLICATION DATA

DISCRIMINATION TABLES

Upstream: TemBreak 2 MCCB (thermal-magnetic)

Downstream: MCB

Upstream MCCB

		S125NJ (36kA) E125NJ (25kA)						S160NJ (36kA)						S250NJ (36kA) E250NJ (25kA)						S400NJ						
Downstream MCB	In	20A	32A	50A	63A	100A	125A	20A	32A	50A	63A	100A	125A	160A	20A	32A	50A	63A	100A	125A	160A	200A	250A	250A	400A	
	6A	260	T	T	T	T	T	T	260	T	T	T	T	T	T	260	T	T	T	T	T	T	T	T	T	T
10A	260	420	T	T	T	T	T	260	420	T	T	T	T	T	260	420	T	T	T	T	T	T	T	T	T	T
16A	260	420	650	T	T	T	T	260	420	650	T	T	T	T	260	420	650	T	T	T	T	T	T	T	T	T
20A	260	420	650	1000	T	T	T	260	420	650	1000	T	T	T	260	420	650	1000	T	T	T	T	T	T	T	T
25A	260	420	650	1000	T	T	T	260	420	650	1000	T	T	T	260	420	650	1000	T	T	T	T	T	T	T	T
32A	260	420	650	1000	1500	T	T	260	420	650	1000	1500	T	T	260	420	650	1000	1500	T	T	T	T	T	T	T
40A	260	420	650	1000	1500	2000	T	260	420	650	1000	1500	2000	T	260	420	650	1000	1500	2000	T	T	T	T	T	T
50A	260	420	650	1000	1500	2000	260	420	650	1000	1500	2000	3000	260	420	650	1000	1500	2000	3000	T	T	T	T	T	T
63A	260	420	650	1000	1500	2000	260	420	650	1000	1500	2000	3000	260	420	650	1000	1500	2000	3000	2600	T	T	T	T	T

- Notes: 1. MCBs can be of any manufacture provided they are Energy class three as defined in EN 60898.
 2. Table based on type B MCBs
 3. MCBs can be 6kA or 10kA at 400V

4. The above table is in accordance with IEC 60947-2, Annex A.
 5. All values shown at 400V AC.
 6. I_s expressed in A.

T= Total Selectivity

APPLICATION DATA

DISCRIMINATION TABLES

Upstream: TemBreak 2 MCCB (electronic).

Downstream: TemBreak 2 MCCB.

Frame		Upstream MCCB																							
		250A			400A					630A			800A			1000A		1250A		1600A					
		Model	S250-NE	S250-GE	S250-PE	H250-NE	S400-NE	S400-GE	S400-PE	H400-NE	L400-NE	E630-NE	S630-CE	S630-GE	S800-NE	S800-RE	H800-NE	L800-NE	S1000-SE	S1000-NE	S1250-SE	S1250-NE	S1250-GE	S1600-SE	S1600-NE
Breaking Capacity	36 kA	65 kA	70 kA	125 kA	50 kA	70 kA	85 kA	125 kA	200 kA	36 kA	50 kA	70 kA	50 kA	70 kA	125 kA	200 kA	50 kA	70 kA	50 kA	70 kA	100 kA	50 kA	100 kA	100 kA	
50A	S50-NF	10kA	T	T	T	T	T	T	T	T	T	T	T	T	T	T	T	T	T	T	T	T	T	T	T
100A	E100-NF	10kA	T	T	T	T	T	T	T	T	T	T	T	T	T	T	T	T	T	T	T	T	T	T	T
125A	E125-NJ	25kA	T	T	T	T	T	T	T	T	T	T	T	T	T	T	T	T	T	T	T	T	T	T	T
	S125-NJ	36kA	T	T	T	T	T	T	T	T	T	T	T	T	T	T	T	T	T	T	T	T	T	T	T
	S125-GJ	65kA	T	T	T	T	T	T	T	T	T	T	T	T	50	T	T	T	T	T	T	T	T	T	T
	H125-NJ	125kA	T	T	T	T	T	T	T	T	T	T	T	T	50	T	T	T	T	T	T	70	T	85	
160A/ 250A	S160-NJ	36kA	-	-	-	-	T	T	T	T	T	T	T	T	T	T	T	T	T	T	T	T	T	T	T
	S160-GJ	65kA	-	-	-	-	T	T	T	T	T	T	T	36	36	T	T	T	50	T	T	T	T	T	T
	H160-NJ	125kA	-	-	-	-	-	-	-	T	T	T	T	T	50	T	T	T	T	T	T	70	T	85	
	E250-NJ	25kA	-	-	-	-	T	T	T	T	T	T	T	T	T	T	T	T	T	T	T	T	T	T	T
	S250-NJ	36kA	-	-	-	-	T	T	T	T	T	T	T	T	T	T	T	T	T	T	T	T	T	T	T
	S250-GJ	65kA	-	-	-	-	T	T	T	T	T	T	T	36	36	T	T	T	50	T	T	T	T	T	T
	S250-NE	36kA	-	-	-	-	-	-	-	T	T	T	T	T	T	T	T	T	T	T	T	T	T	T	T
	S250-GE	65kA	-	-	-	-	-	-	-	T	T	T	T	36	36	T	T	T	50	T	T	T	T	T	T
	H250-NJ	125kA	-	-	-	-	-	-	-	T	T	T	T	T	50	T	T	T	T	T	T	70	T	85	
	S250-PE	70kA	-	-	-	-	-	-	-	T	T	T	T	36	36	T	T	T	50	T	T	70	T	T	
	H250-NE	125kA	-	-	-	-	-	-	-	T	T	T	T	36	36	T	T	T	50	T	T	70	T	85	
	400A/ 630A	E400-NJ	25kA	-	-	-	-	-	-	-	-	-	-	10	10	10	T	T	T	T	T	T	T	T	T
S400-CJ		36kA	-	-	-	-	-	-	-	-	-	-	10	10	10	25	25	25	25	30	30	T	T	T	T
S400-NJ		50kA	-	-	-	-	-	-	-	-	-	-	10	10	10	25	25	25	25	30	30	36	36	36	T
S400-NE		50kA	-	-	-	-	-	-	-	-	-	-	10	10	10	25	25	25	25	30	30	36	36	36	T
S400-GJ		70kA	-	-	-	-	-	-	-	-	-	-	10	10	10	25	25	25	25	30	30	36	36	36	T
S400-GE		70kA	-	-	-	-	-	-	-	-	-	-	10	10	10	25	25	25	25	30	30	36	36	36	T
S400-PJ		85kA	-	-	-	-	-	-	-	-	-	-	10	10	10	25	25	25	25	30	30	36	36	36	T
S400-PE		85kA	-	-	-	-	-	-	-	-	-	-	10	10	10	25	25	25	25	30	30	36	36	36	T
H400-NE		125kA	-	-	-	-	-	-	-	-	-	-	10	10	10	36	36	25	25	T	50	T	T	70	T
E630-NE		36kA	-	-	-	-	-	-	-	-	-	-	-	-	-	-	-	-	-	-	-	T	T	T	T
800A	S800-CJ	36kA	-	-	-	-	-	-	-	-	-	-	-	-	-	-	-	-	-	-	-	-	-	20	20
	S800-NJ	50kA	-	-	-	-	-	-	-	-	-	-	-	-	-	-	-	-	-	-	-	-	-	20	20
	S800-RJ	70kA	-	-	-	-	-	-	-	-	-	-	-	-	-	-	-	-	-	-	-	-	-	20	20
	S800-NE	50kA	-	-	-	-	-	-	-	-	-	-	-	-	-	-	-	-	-	-	-	-	-	20	20
	S800-RE	70kA	-	-	-	-	-	-	-	-	-	-	-	-	-	-	-	-	-	-	-	-	-	20	20

- Notes: 1. All pick-up current and time delay settings are to be set at maximum for upstream MCCBs.
 2. The above table is in accordance with IEC 60947-2, Annex A.
 3. All values shown at 400V AC.
 4. Is expressed in kA.

T= Total Selectivity

WHAT IS CASCADING?

Cascading is a technique where the current limiting capability of upstream circuit breakers is used to permit the installation of lower rated and therefore lower cost circuit breakers downstream.

The upstream TemBreak 2 circuit breaker acts as a resistance against short-circuit currents. With this assistance, downstream circuit breakers with breaking capacities lower than the prospective short-circuit at their point of installation can interrupt the reduced short-circuit current.

Since the current is limited downstream of the limiting circuit breaker, cascading applies to all switchgear in the downstream circuit. It is not restricted to two consecutive devices.

Cascading is recognised by the following standards related to electrical installations:

IEC 60364

BS 7671

AS/NZS 3000

The Advantages

Installation of a single limiting circuit-breaker results in considerable simplifications and savings for the entire downstream installation:

- Simplification of selection of devices using the cascading tables
- Savings on downstream devices. Cascading allows circuit-breakers with lower ratings to be used.

In addition the application of cascading will reduce both electrodynamic and thermal stress within the installation.

APPLICATION DATA

HOW TO READ THE CASCADE TABLES

The value shown in the table is the increased breaking capacity, expressed in kA, that can be achieved if the downstream MCCB is backed up by the appropriate upstream MCCB.

Worked Examples:

Q (1) A 36kA panelboard is required with a 400A incomer and 125A outgoing MCCBs. Can cascading be applied?

A (1) A cost effective solution would be to use an S400-CJ incomer rated at 36kA and E125-NJ MCCBs rated at 25kA downstream.

The upstream S400-CJ MCCB would back up the downstream E125-NJ to 36kA. If this was an 8 Way panelboard you have managed to save cost by installing eight 25kA MCCBs rather than eight 36kA MCCBs.

Q (2) If the same 8 way panelboard was to be used in an 80kA installation, what MCCBs could be used?

A (2) You could still use the E125-NJ provided it was backed up by an L400-NE. The Current limiting capacity of the 400A MCCB would back up the E125A from 25kA to 85kA.

CASCADE TABLES

Upstream: TemBreak 2 MCCB.

Downstream: Din type MCB.

Upstream MCCB

Downstream MCB	Model	E125NJ (25kA)	S125NJ (36kA)	S125GJ (65kA)	S160NJ (36kA)	S160GJ (65kA)	E250NJ (25kA)	S250NJ (36kA)	S250GJ (65kA)
	In	125A	125A	125A	160A	160A	250A	250A	250A
TD3 M06 (6kA)	6A	14	14	14	12	12	12	12	12
	10A	14	14	14	12	12	12	12	12
	16A	14	14	14	12	12	12	12	12
	20A	14	14	14	12	12	12	12	12
	25A	14	14	14	12	12	12	12	12
	32A	14	14	14	12	12	12	12	12
	40A	12	12	12	10	10	10	10	10
	50A	12	12	12	10	10	10	10	10
	63A	12	12	12	10	10	10	10	10

Notes: 1. All values shown at 400V AC.
2. Cascade fault level limit is expressed in kA.

Upstream MCCB

Downstream MCB	Model	E125NJ (25kA)	S125NJ (36kA)	S125GJ (65kA)	S160NJ (36kA)	S160GJ (65kA)	E250NJ (25kA)	S250NJ (36kA)	S250GJ (65kA)
	In	125A	125A	125A	160A	160A	250A	250A	250A
TD3 M10 (10kA)	6A	25	30	30	25	25	25	25	25
	10A	25	30	30	25	25	25	25	25
	16A	25	30	30	25	25	25	25	25
	20A	25	30	30	25	25	25	25	25
	25A	25	30	30	25	25	25	25	25
	32A	25	30	30	25	25	25	25	25
	40A	25	30	30	23	23	23	23	23
	50A	25	30	30	23	23	23	23	23
	63A	25	30	30	23	23	23	23	23

Notes: 1. All values shown at 400V AC.
2. Cascade fault level limit is expressed in kA.

APPLICATION DATA

CASCADE TABLES

Upstream: TemBreak 2 MCCB.

Downstream: TemBreak 2 MCCB.

		Upstream MCCB																
Downstream MCCB	Frame	Model	125A					160A/250A										
	Breaking Capacity		E125NJ	S125NJ	S125GJ	H125NJ	L125NJ	S160NJ	S160GJ	H160NJ	L160NJ	E250NJ	S250NJ	S250GJ	S250PE	H250NJ	H250NE	L250NJ
			25kA	36kA	65kA	125kA	200kA	36kA	65kA	125kA	200kA	25kA	36kA	65kA	70kA	125kA	200kA	
50A	S50NF	10kA	25	25	25	25	25	15	15	25	25	15	15	15	15	25	25	
	E100NF	10kA	25	25	25	25	25	15	15	25	25	15	15	15	15	25	25	
125A	E125NJ	25kA	-	36	50	65	85	36	50	65	85	-	36	50	50	65	85	
	S125NJ	36kA	-	-	65	85	125	-	65	85	125	-	-	65	65	85	125	
	S125GJ	65kA	-	-	-	125	150	-	-	125	150	-	-	70	125	150	200	
	H125NJ	125kA	-	-	-	-	200	-	-	-	200	-	-	-	-	-	200	
160A/ 250A	S160NJ	36kA	-	-	-	-	-	-	65	85	125	-	-	65	65	85	125	
	S160GJ	65kA	-	-	-	-	-	-	-	-	125	-	-	70	125	150	200	
	H160NJ	125kA	-	-	-	-	-	-	-	-	200	-	-	-	-	-	200	
	E250NJ	25kA	-	-	-	-	-	-	-	-	-	36	50	50	65	85		
	S250NJ	36kA	-	-	-	-	-	-	-	-	-	-	65	65	85	125		
	S250GJ	65kA	-	-	-	-	-	-	-	-	-	-	70	125	150	200		
	S250PE	70kA	-	-	-	-	-	-	-	-	-	-	-	125	150	200		
	H250NJ	125kA	-	-	-	-	-	-	-	-	-	-	-	-	-	-	200	

Notes: 1. All values shown at 400V AC.
2. Cascade fault level limit is expressed in kA.

		Upstream MCCB																									
Downstream MCCB	Frame	Model	400A						630A			800A/1000A						1250A/1600A									
	Breaking Capacity		S400CJ	S400NJ	S400NE	S400GJ	S400PJ	S400PE	H400NE	L400NE	E630NE	S630CE	S630GE	S800CJ	S800NJ	S800NE	S800RJ	S800RE	H800NE	L800NE	S1000SE	S1000NE	S1250SE	S1250NE	S1250GE	S1600SE	S1600NE
			36kA	50kA	70kA	85kA	125kA	200kA	36kA	50kA	70kA	36kA	50kA	70kA	36kA	50kA	70kA	125kA	200kA	50kA	70kA	50kA	70kA	50kA	70kA	85kA	50kA
125A	E125NJ	25kA	36	36	50	50	65	85	36	36	50	30	36	36	-	-	-	-	-	-	-	-	-	-	-	-	-
	S125NJ	36kA	-	50	65	65	85	125	-	50	65	-	50	50	-	-	-	-	-	-	-	-	-	-	-	-	-
	S125GJ	65kA	-	-	70	85	125	150	-	-	70	-	-	70	-	-	-	-	-	-	-	-	-	-	-	-	-
	H125NJ	125kA	-	-	-	-	-	200	-	-	-	-	-	-	-	-	-	-	-	-	-	-	-	-	-	-	-
160A/ 250A	S160NJ	36kA	-	50	65	65	85	125	-	50	65	-	50	70	50	50	50	70	-	-	-	-	-	-	-	-	-
	S160GJ	65kA	-	-	70	85	125	150	-	-	70	-	-	70	70	70	70	70	-	-	-	-	-	-	-	-	-
	H160NJ	125kA	-	-	-	-	-	200	-	-	-	-	-	-	-	-	-	-	-	-	-	-	-	-	-	-	-
	E250NJ	25kA	36	36	50	50	65	85	36	36	50	30	36	50	36	36	36	50	-	-	-	-	-	-	-	-	-
	S250NJ	36kA	-	50	65	65	85	125	-	50	65	-	50	70	50	50	50	70	-	-	-	-	-	-	-	-	-
	S250GJ	65kA	-	-	70	85	125	150	-	-	70	-	-	70	70	70	70	70	-	-	-	-	-	-	-	-	-
	S250PE	70kA	-	-	-	-	125	150	-	-	-	-	-	-	85	85	85	85	-	-	-	-	-	-	-	-	-
	H250NJ	125kA	-	-	-	-	-	200	-	-	-	-	-	-	-	150	-	-	-	-	-	-	-	-	-	-	-
400A	E400NJ	25kA	36	36	50	50	65	85	36	36	50	30	36	50	36	36	36	50	36	36	36	36	36	36	36	36	36
	S400CJ	36kA	-	50	65	65	70	100	-	50	65	-	50	70	50	50	50	70	-	-	-	-	50	50	50	50	50
	S400NJ	50kA	-	-	70	70	85	125	-	-	70	-	-	70	70	70	70	70	-	-	-	-	70	70	70	70	70
	S400GJ	70kA	-	-	-	85	125	150	-	-	-	-	-	-	85	85	-	-	-	-	-	-	-	-	-	-	85
	S400PJ	85kA	-	-	-	-	125	150	-	-	-	-	-	-	-	-	-	-	-	-	-	-	-	-	-	-	-

Notes: 1. All values shown at 400V AC.
2. Cascade fault level limit is expressed in kA.

The Application of MCCBs in DC Systems

Terasaki's MCCBs provide an excellent range of protection for DC installations. We offer MCCBs of up to 1000A with DC overload protection and up to 2500A with DC short-circuit protection.

Protection Method

Current transformers require alternating current to generate magnetic flux thereby inducing current to flow in the secondary winding. Any device which relies on current transformers for measurement or detection of current is therefore unsuitable for protection of DC systems. Most electronic MCCBs fall into this category.

The most common method of detecting DC overloads is by the use of a thermal element. Short-circuit protection in DC circuits is provided by electromagnetic tripping elements.

Tripping Characteristics

The time-current characteristics of a thermal element, such as those published in Section 3, are unaffected by the frequency of current applied. They hold good for both AC and DC currents.

A magnetic element operates on the instantaneous value of the current waveform. This means that in practice in an AC circuit, it will operate at the peak value of the sinusoidal waveform. Tripping characteristics are published in AC root mean square (rms) Amperes (A). This means that the value of AC instantaneous current, I_p , which will operate the element is equal to the rms current multiplied by $\sqrt{2}$. Similarly, the value of DC instantaneous current which will operate the element is equal to the AC rms current multiplied by $\sqrt{2}$.

DC operating current of magnetic element = $\sqrt{2} \times$ AC rms operating current of magnetic element.

Time Constant

Time constants associated with DC circuits prevent the voltage of the circuit from reacting immediately when a load current is suddenly interrupted.

The time constant, τ , of a circuit indicates how quickly voltage across capacitors and current through inductors react to transient conditions.

The time constant of a capacitive circuit is the product of capacitance and resistance:

$$\tau = RC \text{ (s)}$$

The time constant of an inductive circuit is given by:

$$\tau = L/R \text{ (s)}$$

APPLICATION DATA

The Application of MCCBs in DC Systems

Time Constant

Transient voltages and currents, including those produced by switching, do not approximate their steady state values until 5 time constants have elapsed.

Fault currents occurring in circuits with high time constants are extremely difficult to interrupt due to the lagging voltage. All DC breaking capacities in this section are shown with the assumption that the time constant of the circuit is restricted to the values shown below.

Fault Level	τ
Near the rated current, I_n , of the circuit breaker	<2.0ms
<2.5 x I_n	<2.5ms
<10kA	<7ms
>10kA	<15ms

Breaking Capacity

The short-circuit ratings of MCCBs suitable for DC installations are shown in the table below. In some cases, two or more poles must be connected in series to achieve the given rating, this is also indicated in the table.

Please refer to catalogue I73E for further details.

DC Breaking Capacity, I_{cu} (kA), Protection and Reference								
Voltage	250V DC	350V DC	500V DC		600V DC		Protection	
Poles in Series	2	3	3	4	3	4	Overload	Short Circuit
E125-NJ	25	–	–	–	–	–	Thermal, adjustable	Magnetic, adjustable
S125-ND	–	10	–	7.5	–	5	Thermal, adjustable	Magnetic, fixed
S125-GJ	40	–	–	–	–	–	Thermal, adjustable	Magnetic, adjustable
S160-ND	–	10	–	7.5	–	5	Thermal, adjustable	Magnetic, fixed
E250-NJ	25	–	–	–	–	–	Thermal, adjustable	Magnetic, adjustable
S250-ND	–	10	–	7.5	–	5	Thermal, adjustable	Magnetic, fixed
E400-NJ	25	–	–	–	–	–	Thermal, adjustable	Magnetic, adjustable
S400-CJ	–	–	–	–	–	–	Thermal, adjustable	Magnetic, adjustable
S400-ND	–	20	15	–	15	–	Thermal, adjustable	Magnetic, fixed
S800-CJ	50	–	–	–	–	–	Thermal, adjustable	Magnetic, adjustable
S800-ND	–	30	20	–	20	–	Thermal, adjustable	Magnetic, fixed
XS1000ND	50	30	20	20	20	20	Thermal, fixed	Magnetic, adjustable
XS1250ND	50	50	50	50	20	20	–	Magnetic, adjustable
XS1600ND	50	50	50	50	20	20	–	Magnetic, adjustable
XS2000ND	50	50	50	50	20	20	–	Magnetic, adjustable
XS2500ND	50	50	50	50	20	20	–	Magnetic, adjustable

TEMBREAK 2

MOULDED CASE CIRCUIT BREAKERS 16A TO 1600A

1. Welcome to TemBreak 2
2. Ratings and Specifications
3. Operating Characteristics
4. Application Data
5. **Accessories**
 - **Electrical Control (Internal Accessories)** 81
 - **Termination of Control Wiring** 86
 - **Electrical Control (Motorised Operation)** 87
 - **Operating Handles & Locking Devices** 92
 - **Insulation Accessories** 95
 - **Dual Supply Changeover Systems** 98
6. Installation
7. Dimensions



ACCESSORIES

ELECTRICAL CONTROL USING INTERNALLY MOUNTED ACCESSORIES

Electrical control accessories for TemBreak 2 are designed with the installer in mind. Status and alarm contacts, remote tripping coils and undervoltage protection coils are of modular design and convenient to use.

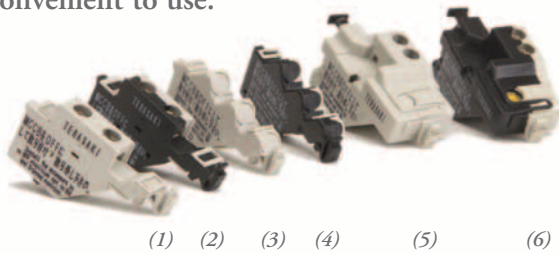

- 1) Heavy-duty auxiliary switch
- 2) Heavy-duty alarm switch
- 3) General-purpose auxiliary switch
- 4) General-purpose alarm switch
- 5) Shunt trip
- 6) Undervoltage trip

- Every accessory fits every MCCB and Switch-Disconnecter in the range.
- All accessories are endurance tested to the same level as MCCBs.
- TemBreak 2 internal accessories are easily field-installable.
- All accessories are individually packaged and are supplied with fitting instructions.
- Control wiring is terminated on the accessory screw terminal. Alternatively a terminal block which clips to the side of the MCCB is available.

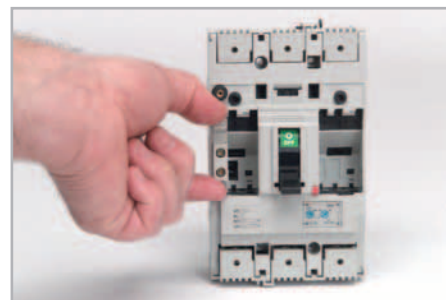

Installing Accessories in a 4 pole S400 model

The internal accessories can be easily installed in the field without special tools or product training.

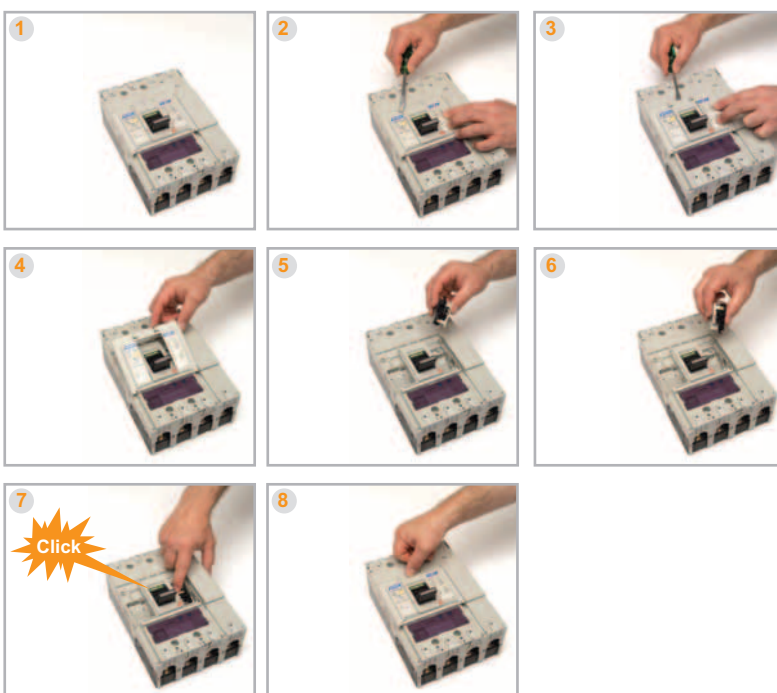

Easy field-Installation of Accessories

- Internal accessory can be simply plugged into position
- No tools are required for this, except a screwdriver to lift the MCCB front cover clips.
- Accessories fit with a firm click when installed correctly.
- Colour coding of accessories helps identification and installation

ELECTRICAL CONTROL USING INTERNALLY MOUNTED ACCESSORIES

Valid Maximum Accessory Combinations

Frame size (A)	125	160 and 250	400 and 630	800 and 1000	1250 and 1600
E	E125	E250	E400 E630		
S	S125	S160 S250	S400 S630	S800 S1000	S1250 S1600
H		H125 H160 H250	H400	H800	
L		L125 L160 L250	L400	L800	
General Purpose Auxiliary Switch General Purpose Alarm Switch Shunt Trip					
General Purpose Auxiliary Switch General Purpose Alarm Switch Undervoltage Trip					
Heavy Duty Auxiliary Switch Heavy Duty Alarm Switch Shunt Trip					
Heavy Duty Auxiliary Switch Heavy Duty Alarm Switch Undervoltage Trip					

- Auxiliary Switch
- Alarm Switch
- Shunt Trip
- Undervoltage Trip

- General purpose and heavy duty status indication switches cannot be mixed in the same MCCB.
- It is not possible to install a shunt trip and an undervoltage trip in an MCCB as they occupy the same location. Undervoltage trips can provide remote tripping if necessary by wiring a normally closed contact or pushbutton in series with the protected supply.
- Undervoltage trips with time delays require an external time delay controller which clips to the side of the MCCB.

ACCESSORIES

ELECTRICAL CONTROL USING INTERNALLY MOUNTED ACCESSORIES

Status Indication Switches



General Purpose Auxiliary Switch

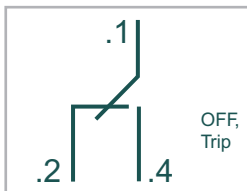

Terminal Designations and Function of General Purpose Auxiliary Switch



General Purpose Alarm Switch

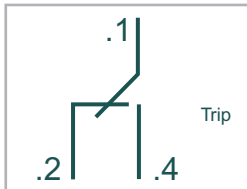

Terminal Designations and Function of General Purpose Alarm Switch

General Purpose Auxiliary Switch (AX)

An auxiliary switch electrically indicates the ON or OFF status of the MCCB. The general purpose type is a changeover switch with 3 terminals.

A microcurrent version is available for switching currents as low as 1mA.

Auxiliary switches are colour coded grey. The cable capacity of the terminals is 0.5 to 1.25mm².

The general purpose auxiliary switch meets the requirements of IEC 61058-1.

General Purpose Alarm Switch (AL)

An alarm switch electrically indicates the TRIP status of the MCCB. The general purpose type is a changeover switch with 3 terminals.

A microcurrent version is available for switching currents as low as 1mA.

Alarm switches are colour coded grey and black. The cable capacity of the terminals is 0.5 to 1.25mm².

The general purpose alarm switch meets the requirements of IEC 61058-1.

General purpose auxiliaries and alarm switch ratings						
Volts (V)	AC		Volts (V)	DC		Minimum Load
	Amperes (A)			Amperes (A)		
	Resistive Load	Inductive Load		Resistive Load	Inductive Load	
440	-	-	250	-	-	100mA at 15V DC.
240	3	2	125	0.4	0.05	
110	3	2	30	3	2	

Microcurrent versions			
Volts (V)	DC		Minimum Load
	Amperes (A)		
	Resistive Load		
30	0.1		1mA at 5V DC and 30V DC.

ELECTRICAL CONTROL USING INTERNALLY MOUNTED ACCESSORIES

Status Indication Switches



Heavy Duty Auxiliary Switch



Terminal Designations and Function of Heavy Duty Auxiliary Switch, a contact



Terminal Designations and Function of Heavy Duty Auxiliary Switch, b contact



Heavy Duty Alarm Switch



Terminal Designations and Function of Heavy Duty Alarm Switch, a contact



Terminal Designations and Function of Heavy Duty Alarm Switch, b contact

Ratings of Heavy Duty Auxiliary and Alarm Switches					
AC			DC		
Volts (V)	Amperes (A)		Volts (V)	Amperes (A)	
	Resistive Load	Inductive Load		Resistive Load	Inductive Load
500	1	1	-		
440	3	3	250	0.5	0.5
240	4	4	125	1	1
110	5	5	48	3	2.5
48	6	6	24	6	2.5

Heavy Duty Auxiliary Switch (AX)

The heavy duty auxiliary switch has an impulse withstand voltage (U_{imp}) of 6kV and is suitable for isolating safety circuits. The auxiliary switch electrically indicates the ON or OFF status of the MCCB. The heavy duty type is a bridge switch with two terminals. It is available in either normally open or normally closed configurations.

Heavy duty auxiliary switches are colour coded grey. The cable capacity of the terminals is 1.25 to 2.5mm².

The heavy duty auxiliary switch meets the requirements of IEC 60947-5-1.

It has direct opening action, recommended by IEC 60204-1 Safety of Machinery - Electrical Equipment for Machines.



Heavy Duty Alarm Switch (AL)

The heavy duty alarm switch has an impulse withstand voltage (U_{imp}) of 6kV and is suitable for isolating control circuits. The alarm switch electrically indicates the TRIP status of the MCCB. The heavy duty type is a bridge switch with two terminals. It is available in either normally open or normally closed configurations.

Heavy duty auxiliary switches are colour coded grey and black. The cable capacity of the terminals is 1.25 to 2.5mm².

The heavy duty alarm switch meets the requirements of IEC 60947-5-1.

It has direct opening action, recommended by IEC 60204-1 Safety of Machinery - Electrical Equipment for Machines.



ACCESSORIES

ELECTRICAL CONTROL USING INTERNALLY MOUNTED ACCESSORIES

Remote Tripping Devices

Shunt Trip (SHT)

A shunt trip allows an MCCB to be tripped remotely on the application of the rated coil voltage across the shunt trip terminals. TemBreak 2 shunt trips have **continuously rated coils** and are suitable for use in electrical interlocking applications.

The MCCB contacts and toggle will move to the tripped position when the shunt trip is operated.

The permissible voltage range is 85% to 110% for AC or 75% to 125% for DC.

The cable capacity of the terminals is 0.5 to 1.25mm². Shunt trips are colour coded grey.



Shunt Trips



Terminal Designations of Shunt Trips

Ratings of Shunt Trips							
Rated Voltage	Voltage AC			Voltage DC			
	100-120	200-240	380-450	24	48	100-120	200-240
Excitation Current (A)	0.014	0.014	0.0065	0.03	0.03	0.011	0.011

Under Voltage Trip (UVT)

An undervoltage trip will trip the breaker automatically when the voltage applied to the terminals of the undervoltage coil drops to between 70% and 35% of its voltage rating. The undervoltage trip prevents the circuit breaker being closed unless a voltage corresponding to at least 85% of its voltage rating is applied across the terminals of the undervoltage coil.

The MCCB contacts and toggle will move to the tripped position when the under-voltage trip operates.

Undervoltage trips with AC operating voltages are available with 500ms time delays. Time-delay units are fitted to the outside of MCCBs.

The cable capacity of the terminals is 0.5 to 1.25mm². Undervoltage trips are colour coded grey and black.

A UVT controller is required for time delay UVT only.



Undervoltage Trips

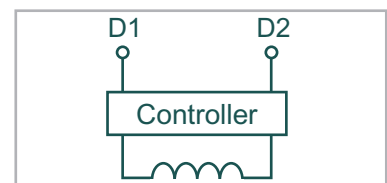

Terminal Designations of Undervoltage Trips

Ratings of Undervoltage Trips										
MCCB Model	Rated Voltage	Power supply capacity (VA)						Excitation current (mA)		
		Voltage AC			Voltage DC			24	100-120	200-240
E125, S125, H125, L125, S160, H160, L160, E250, S250, H250, L250, E400, S400, H400, L400, E630, S630		100-120	200-240	380-450	24	100-120	200-240	23	10	10
		1.4	2.8	2.3						
MCCB Model	Rated Voltage	Voltage AC						Voltage DC		
		100-110	115-120	200-220	230-240	380-415	440-450	24	100-120	200-240
S800, H800, L800, S1000, S1250, S1600		1.5	1.6	2.4	2.9	2.1	2.3	29	13	11

TERMINATION OF CONTROL WIRING

Terminal blocks are for optional use with all types of internally mounted accessory.



Terminal Block for Plug-in MCCBs

The terminal block for a plug-in MCCB consists of:

- a male section pre-fitted with 3 cables with which clips easily to the back of the MCCB
- a female section with 3 user terminals which clips easily into the plug-in base.

Up to 4 terminal blocks can be installed on a 125A, 160A or 250A frame MCCB. Up to 5 terminal blocks can be installed on a 400A to 800A frame MCCB.

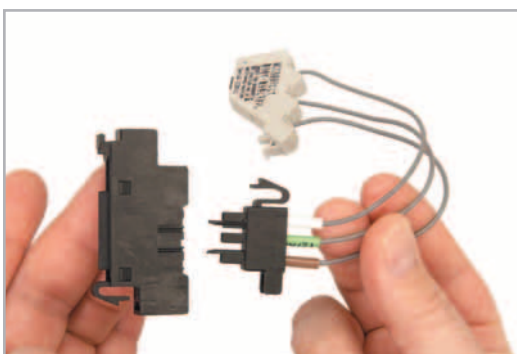

Terminal Block for Plug-in MCCBs

Terminal Block for Front-Connected and Rear-Connected MCCBs (TF)

A terminal block facilitates convenient and accessible control wiring to internally mounted accessories especially the accessories with lead wire.

It allows the use of control wiring cables with larger cross-sectional area than permitted by the internal accessories themselves.

This terminal block can be clipped to either side of the MCCB. If mounted on the left incoming wiring will be fed vertically up to the terminals. If mounted on the right, the incoming wiring will be fed vertically down to the terminals.

The maximum incoming cable size to the terminal block is 2.0mm². 11 terminals or 6 terminals can be specified. See page 153.



Terminal Block for Front-Connected and Rear-Connected MCCBs

ACCESSORIES

ELECTRICAL CONTROL USING MOTORISED OPERATION

Overview – Motor Operators (MC)

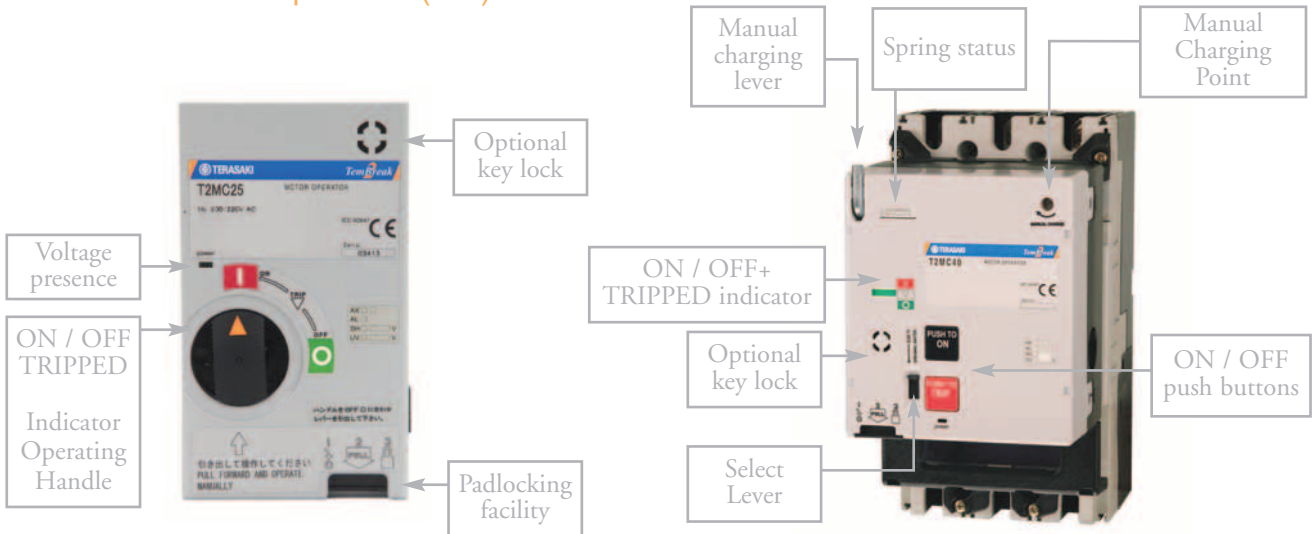

Motor Operator for 125A and 250A Frame MCCB's

Motor Operator for 400A and 630A Frame MCCB's

Motor operators provide the possibility of opening and closing an MCCB on application of electrical control signals. TemBreak 2 motor operators are extremely reliable, having been designed to endure the same switching duty as the host MCCB.

- Easy field-installation.
- Fast operation ($\leq 100\text{ms}$).
- Positive contact indication.
- Padlocking facility as standard (Maximum 3, hasp diameter 8mm).
- Optional keylock.
- Versions available with automatic reset function.
- Voltage presence indication.

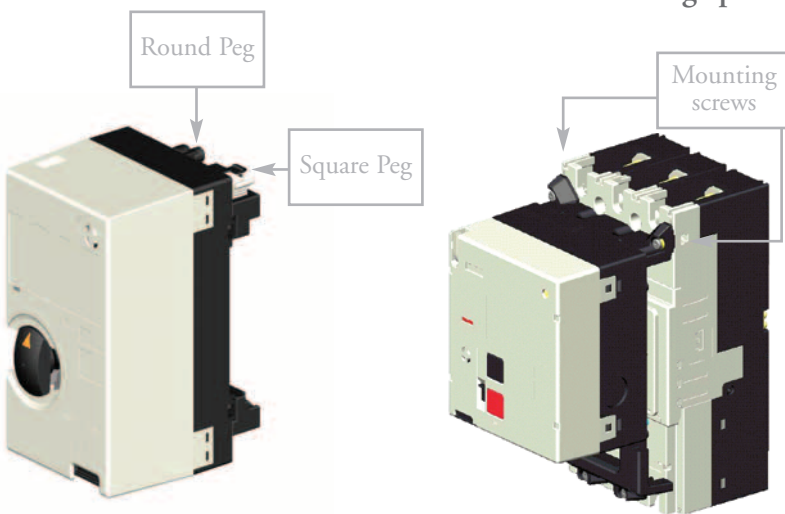

Motor Operator for 125A and 250A frame MCCB's

Motor Operator for 400A and 630A frame MCCB's

Motor operators for 125A and 250A frame are mounted on the front of the breaker. They can be rapidly fitted by locating the round pegs and square pegs on the motor into corresponding round and square holes on the breaker. It takes less than 10 seconds to secure the motor to the MCCB. Two levers securely lock the motor into position. No tools are needed to fit the motor operator.

400A frame to 1000A frame motor operators are held in place with mounting screws. They can be installed easily in the field.

ELECTRICAL CONTROL USING MOTORISED OPERATION

Indication of ON, OFF or TRIPPED Status

The handle of 125A and 250A frame motor operators has dual functions:

1. Indication of ON, OFF or TRIPPED status as shown in the photographs below;
2. Manual operation when handle is pulled out. The supply to electrical control circuits inside the motor operator is cut when the handle is pulled out.



MCCB on



MCCB off



MCCB tripped



Motor operators for 400A to 1000A frame MCCBs incorporate a mechanical flag which indicates the ON, OFF and TRIPPED status of the MCCB. They can be manually charged using the lever provided.

Ratings and Specifications

Type of Motor Operators		T2MC12	T2MC25	T2MC40	T2MC80
Applicable MCCB		E125	E250	E400	S800, S1000
		S125	S160, S250	S400	H800
			H125, H160, H250	E630	L800
			L125, L160, L250	S630	
Rated operating voltage	100-110 V AC	■		■	■
	200-220 V AC	■		■	■
	230-240 V AC	■		■	■
	24 V DC	■		■	■
	48 V DC	■		■	■
	100-110 V DC	■		■	■
	200-220 V DC	■		NA	NA
Operating current/ Starting current Peak value (A)	100-110 V AC	4.5/8		ON ---/2.3 OFF, RESET 1.4/3.7	ON ---/2.2 OFF, RESET 1.7/3.5
	200-220 V AC	4/8		ON ---/2.3 OFF, RESET 1.1/3.5	ON ---/2.2 OFF, RESET 1.3/3.5
	230-240 V AC	3.5/7		ON ---/2.3 OFF, RESET 1.1/3.5	ON ---/2.2 OFF, RESET 1.3/3.5
	24 V DC	18/26		ON ---/7.2 OFF, RESET 3.9/8.1	ON ---/12 OFF, RESET 6.0/11.5
	48 V DC	12/18		ON ---/7.2 OFF/RESET 2.0/5.1	ON ---/7 OFF, RESET 3.2/6.5
	100-110 V DC	2.2/6		ON ---/2.4 OFF/RESET 1.2/3.8	ON ---/2.2 OFF, RESET 1.3/3.5
	200-220 V DC	2.2/5.5		—	—
Operating method		Direct drive		Spring charging	Spring charging
Operating time (s)	ON	0.1		0.1	0.1
	OFF	0.1		1.5	1.5
	RESET	0.1		1.5	1.5
Operating switch rating		100V, 0.1 A, Opening voltage 44V, current 4mA		100V, 0.1 A, Opening voltage 48V, current 1mA	
Power supply required		300 VA minimum		300VA minimum	300VA minimum
Dielectric properties (1 min)		1500 V AC (1000V AC for 24V DC and 48V DC motors)			
Weight		1.4 kg		3.5kg	3.5kg

■ = Available

Note: Operating times shown in the above table apply only when the rated operational voltage is supplied to the motor operator. The voltage supplied to the motor operator must be within the range of 85% and 110% of the rated operating voltage.

ACCESSORIES

ELECTRICAL CONTROL USING MOTORISED OPERATION

Motor Operator Control Circuits



MCCB and Motor Operator Showing Control Wiring Socket

The Control circuits for Motor Operators are connected using a simple plug and socket system.



Control Wiring Plug

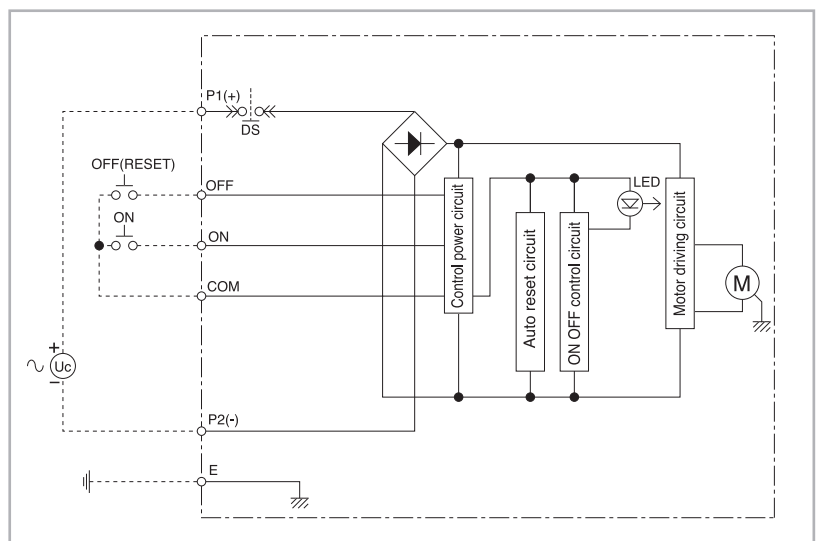

Control circuit for Motor Operators

Operation

The motor operator incorporates a self-hold circuit for the closing and opening signals. Therefore a momentary (over 50msec.) open or close signal will ensure a complete operation.

When the breaker trips, the breaker is reset by applying a signal to the OFF terminals of the motor.

When a UVT is used with a motor operator, design the control circuit so that the UVT is energised **before** a reset or close signal is sent to the motor operator. A 40ms time delay in the reset and close signals is sufficient to allow the UVT to energise.

When a shunt trip is used with a motor operator, design the control circuit so that the shunt trip is de-energised before a reset or close signal is sent to the motor operator.

When a mechanical interlock is used with motor operators, design the control circuit to provide electrical interlocking between the motor operators. The electrical interlocking should prevent a close signal being sent to a motor operator unless the other motor operator and circuit breaker are in the OFF position.

Auto- reset

Two types of motor operator are available: motor operators without auto-reset and motor operators with auto-reset. The correct type of motor operator should be selected for the application. MCCB auxiliary and alarm switches do not have to be used in the control circuits for motor operators whether they have auto-reset or not, saving cost and space.

ELECTRICAL CONTROL USING MOTORISED OPERATION

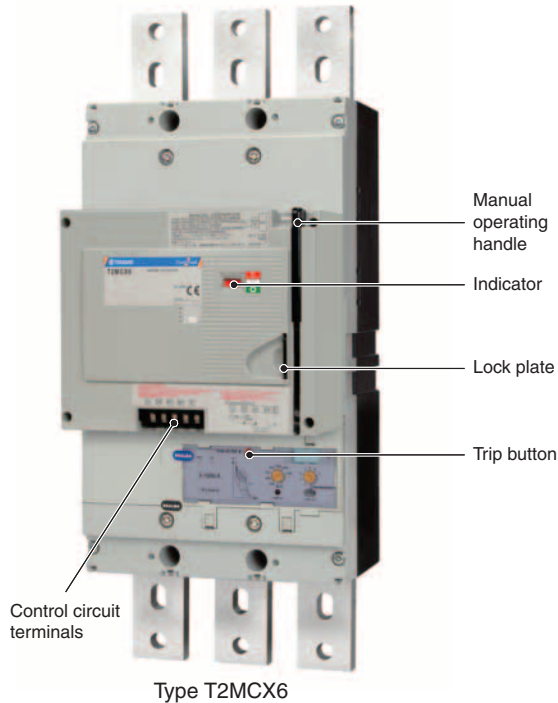

Type T2MCX6

Positive contact indication

Colour coding indicates the true position of the contacts clearly: ON (red), OFF (green), TRIP (white).

Easy maintenance

Breaker mounting, removal, and even setting changes can be done without removing the motor operator.

Manual ON/OFF operation with one stroke

Fast closing operation

Closing in 60ms or less. The closing time remains constant over repeated operations.

Ratings and Specifications

Type of Motor Operators		T2MCX6	
Applicable MCCB		S1250 S1600	
Rated Operating Voltage (V)	AC	100-115V 50/60Hz	■
		200-230V 50/60Hz	■
	DC	100-110V	■
		24V	■
Lock in "OFF" position (standard)		■	
Manual Trip Button		*	
Steady-state r.m.s. Amp/inrush Amp (A)	AC100-115V	ON①	-/3.1
		OFF, RESET①	1.8/6.0
	AC200-230V	ON②	-/1.2
		OFF, RESET②	1.0/3.2
	DC100-110V	ON③	-/0.8
		OFF, RESET③	1.1/4.2
	DC24V	ON	-/4.5
		OFF, RESET	4.0/12.0
Type of operation		Spring Charged	
Operating Time(s)	ON (Maximum values)		0.06
	OFF, RESET④		3
Control Switch Ratings		250V, 5A	
Power Source Capacity (VA)		300VA	
Dielectric withstand voltage The value in brackets for 24V DC		AC1500V (AC500V)	
Weight (kg)		6.4	

■ = Available

* Trip button on breaker to be used (accessible with motor fitted)

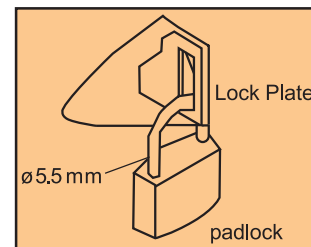

The breaker can be padlocked in the "OFF" position by pulling out the lock plate, and locking it with a padlock.
When the breaker is "ON", the lock plate cannot be pulled out.
Up to three locks can be used.
Padlocks not supplied.

NOTE

① : Maximum values at AC115V, 50Hz

② : Maximum values at AC230V, 50Hz

③ : Maximum values at DC110V

④ : Maximum values at the rated operating voltages

ACCESSORIES

ELECTRICAL CONTROL USING MOTORISED OPERATION

Motorised operation

ON CONTROL

When the ON switch is closed, the latch release coil (LRC) is excited and the closing spring is released. The breaker quickly closes and goes into ON status. When the closing spring is released, the limit switch (LS) is opened and the LRC is de-excited.

OFF CONTROL

When the off switch is closed, self-hold control relay (Y) is activated and motor (M) operates to charge the closing spring. The breaker changes to OFF status.

RESET CONTROL

When the breaker is in TRIP status, closing the OFF switch activates self-hold control relay (Y) and starts motor (M). Motor (M) charges the closing spring and resets the breaker.

Manual operation

ON, OFF (RESET)

The breaker can be opened (OFF or RESET) and closed (ON) alternately by pulling the operating lever down in one full stroke. ON/OFF operation of the breaker is possible without charging or releasing the closing spring.

Emergency Trip

Opening the breaker (OFF) using the motor operator takes up to 3 seconds. If a remote emergency OFF function is necessary, incorporate the shunt trip device (SHT) into the breaker.

PRECAUTIONS REGARDING USAGE

- If using the UVT option, be sure to reset the UVT before closing the breaker.
- The motor operator must be supplied with voltage within the following range:
DC: 75-110% of rated voltage
AC: 85-110% of rated voltage
Operation at low voltage may burn out the motor.

Anti-pumping function

When the breaker is turned ON and the closing spring is released, self-hold control relay X is activate. Xa-contact is held closed, and Xb-contact is opened. While the ON switch is closed, latch release coil (LRC) will not be excited even if the OFF switch is closed or an automatic reset circuit is being used. Pumping is thus prevented.

Automatic charge/discharge function

If the breaker is closed manually (ON) while the power source is on, the handle switch (HS) induces automatic release of the closing spring. Likewise, if the breaker is opened manually (OFF), the springs are automatically charged. If the breaker is opened or closed while the power source is off, later when the power source is turned on, the closing spring will automatically be charged or discharged to match the ON/OFF status of the breaker. This automatic charge/discharge function is necessary to prepare the closing mechanism for the next ON/OFF operation. The sound of the charging or discharging of the spring should not be mistaken for a malfunction.

Automatic reset

An alarm switch (a-contact) fitted in the breaker, can be used to induce recharging of the closing spring and automatically reset the MCCB. Connect the automatic reset circuit as shown below.

If the alarm switch is used, a pulse signal will be produced in the automatic reset circuit when the alarm is activated. Be sure to use a self-hold circuit to avoid possible problems caused by this pulse signal.

It is recommended that a time delay of approximately 3 minutes is introduced to the automatic reset circuit for thermal magnetic MCCB's. In the event of an overload trip this will prevent the motor operator repeatedly driving the MCCB between the tripped and reset positions while the thermal element is hot.

If an alarm signal is also required for external control, use a 2 alarm switch combination.

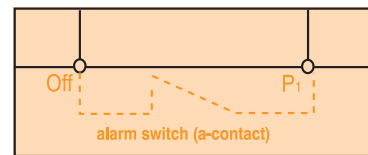

Control circuit AC and DC

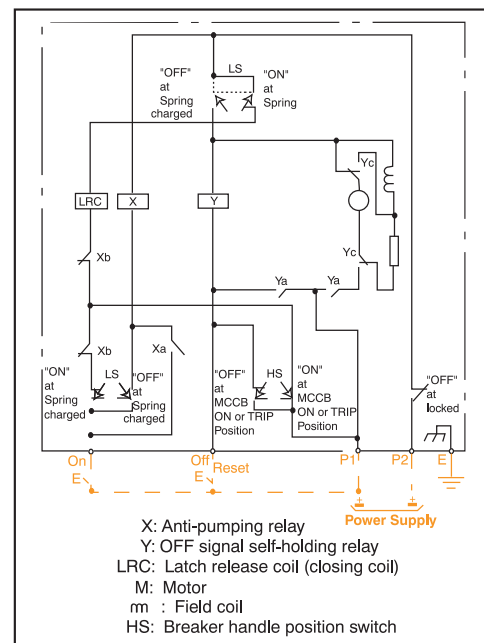

Note: Customer wiring shown in orange

OPERATING HANDLES & LOCKING DEVICES

TemBreak 2 external operating handles are extremely reliable, having been designed to endure the same switching duty as the host MCCB.

It is easy to fit the operating unit to the MCCBs up to 250A frame. Fitting involves three easy steps:

1. Align breaker toggle with operating mechanism
2. Push external operating handle into position (the handle's round pegs locate securely in the breaker's round holes and the external operating handle's* square pegs in the breaker's square holes).
3. Twist locking screws through 45 degrees.*

Safety Features

- Door interlock mechanism with override facility included as standard
- IP55 as standard (HS), IP54 as standard (HP), IP3X as standard (HB)
- IP65 optional (HS, HP), IP5X optional (HB)
- Locks OFF with up to 3 padlocks (8mm hasps)
- Optional Key fitting facility is available for Castell FS1 (HS)
Contact us for the details of mounting dimension.
- Optional keylock in OFF position (HP, HB)
- Available Gray handle with Black base or Red handle with Yellow base (HS)
- Available in black or red and yellow (HP, HB)
- A trip test can be performed with the external operating handle fitted to the MCCB

Orientation

To switch the breaker from OFF to ON the external operating handle is rotated through 90 degrees in a clockwise direction.

The ON (I) and OFF (O) indication of the external operating handle can be re-oriented in steps of 90 degrees with respect to the operating mechanism. This allows the indication position to remain the same whether the breaker is mounted vertically (right side up or upside down) or horizontally (on its left side or on its right side).

The hole cut-out dimensions for a panel or door will remain unchanged if the external operating handle is re-oriented. The external operating handle's axis of rotation is on the intersection of the centre lines of a 3P MCCB. This means that the positioning of the door cutouts is symmetrical for breakers mounted horizontally on either side of a vertical busbar system.

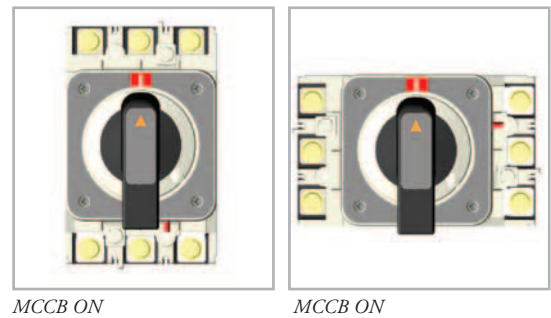

Cubicle Door Cutouts

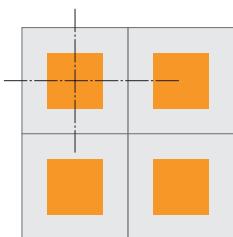

Using TemBreak 2 Operating Handles

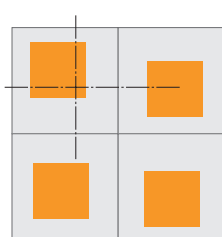

Using other MCCB Operating Handles

*external operating handles for 400A and 1600A Frame models are secured with four screws.

ACCESSORIES

OPERATING HANDLES & LOCKING DEVICES

Door Mounted Handle (HS) standard type

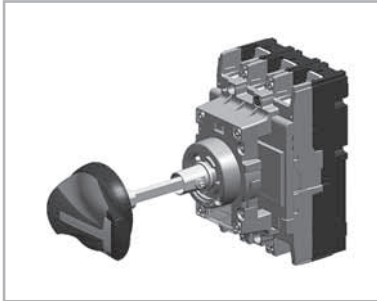

The door mounted handles allow breakers installed in control centers or switchboards to be manually operated from outside and complies with IEC 60204-1.

It consists of an operating mechanism that is mounted on the breaker, an operating handle that is mounted on the door, and a shaft that transmits the turning force from the handle to the operating unit. The shaft can be cut to the required length.

The shaft support makes easy to insert to the operating handle when the panel door is being closed.

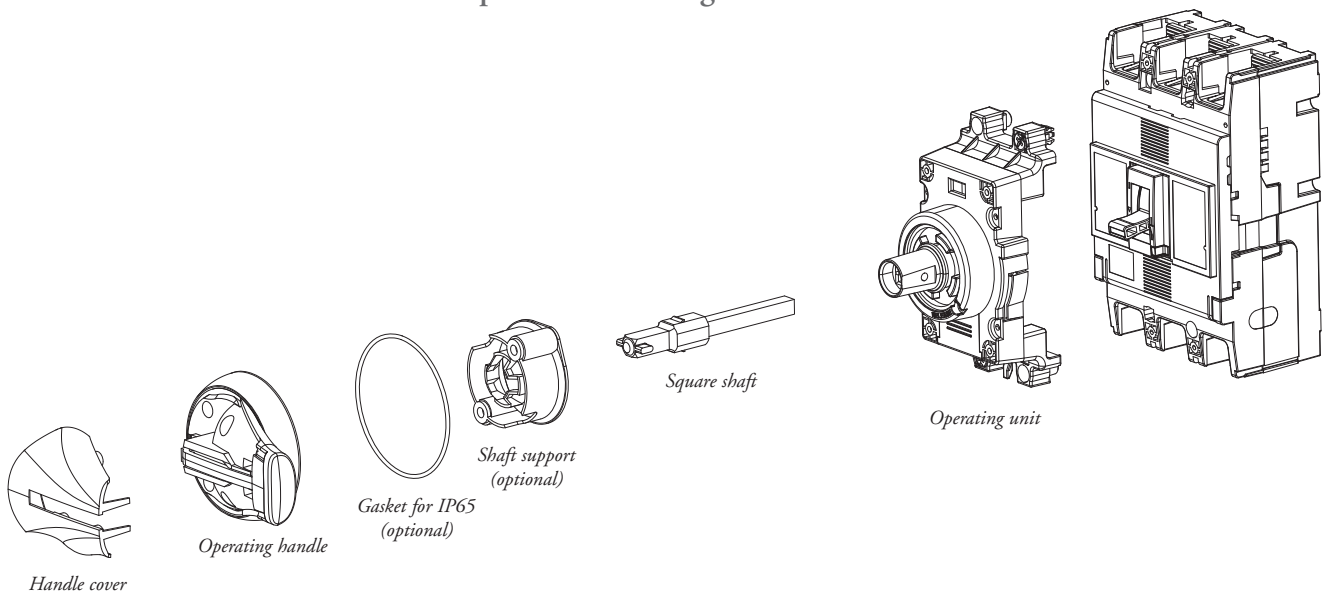

Door interlock mechanism

The external operating handle keeps the panel door locked when in the 'ON' position. There is OFF open type only.

OFF open type

The handle is turned to the OFF position to open the panel door.

- Door interlock release button

The release button enables the panel door to be opened with the handle in the 'ON' position.

To release: push the release button on the side of the operating handle with a flat-bladed screwdriver.



Toggle lock mechanism

- Padlock (Standard)

This mechanism allows the breaker to be padlocked in the OFF position.

Padlocks are not supplied.

Up to three padlocks can be installed.

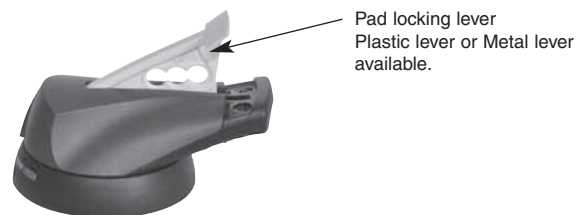

OPERATING HANDLES & LOCKING DEVICES

Door Mounted Handle (HP) ordinal type

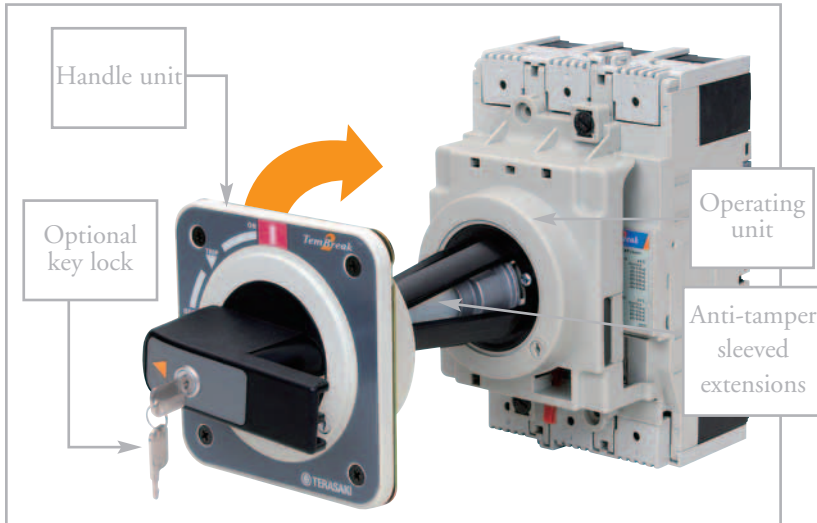

Door Mounted Handle with Optional Keylock

The door mounted handle is used to operate a circuit breaker mounted inside a cubicle from outside the door. It consists of an operating mechanism that is mounted on the breaker, an operating handle that is mounted on the door, and a shaft that transmits the turning force from the handle to the operating unit. The shaft can be cut to the required length.

Breaker Mounted Handle (HB)

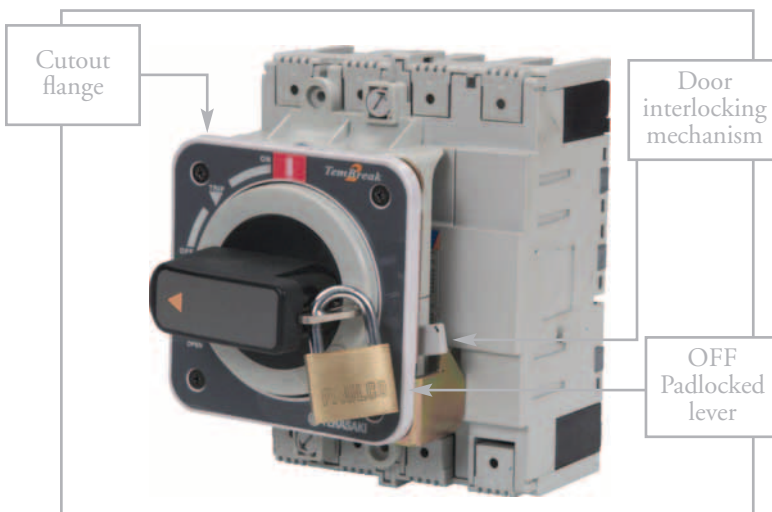

Breaker Mounted Handle Padlocked in the OFF Position

This external operating handle is used to operate a circuit breaker mounted just behind a compartment door with the door closed. The operating unit and the handle itself are mounted directly onto the circuit breaker. The handle protrudes through a cutout in the door. A moulded door flange is supplied with the external operating handle which covers the cutout from the front.

Padlocking and keylocking is possible in the OFF position.

Locking Devices

Toggle locking devices allow MCCBs to be locked ON or OFF using up to three padlocks. Locking devices for 125A, 160A and 250A frame models accept padlocks with 5mm hasp diameter. Locking devices for 400A to 1600A frame models accept padlocks with 8mm hasp diameter.



S250 Locked OFF



S400 Locked OFF

Fittings for Castell and Fortress locks are available. They are suitable for use on door mounted handles (HP) for MCCBs.

ACCESSORIES

INSULATION ACCESSORIES

Terminal Covers

Terminal covers are used to prevent direct contact with live MCCB terminations. They also provide additional insulation to reduce the possibility of a short circuit between phases or to earth when large conductors are used.

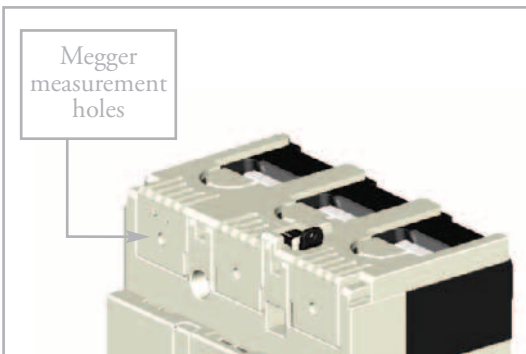

Terminal Cover Lock with Lead Seal



Earth Barrier Fitted to Rear of Terminal Cover

General features

- Terminal covers for 125A to 630A frame models require no tools for installation
- Terminal covers for 125A to 630A frame models have an IP20 ingress protection rating
- Terminal covers are ordered individually. Two terminal covers are required to cover both the line and load terminals of an MCCB. Each cover can either be fitted to the top or bottom of the MCCB
- Terminal covers have a megger measurement hole of 4mm diameter on each phase.

Options

- A terminal cover for 125A to 630A frame models lock allows an anti-tampering seal to be added.
- An earth barrier for 125A and 250A frame models can be added to terminal covers for front connection. The earth barrier provides insulation at the rear of the terminations.

INSULATION ACCESSORIES

Terminal Covers for Front Connection (CF)

Terminal covers for front connection are suitable for covering the exposed live parts of conductors terminated on the MCCB.

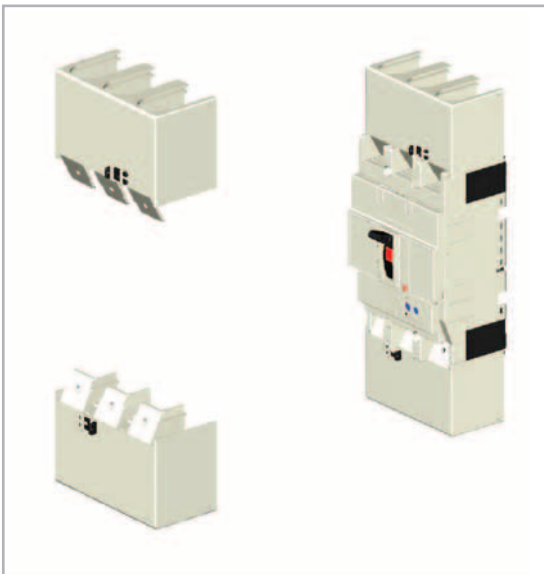

Terminal Covers for Front Connection

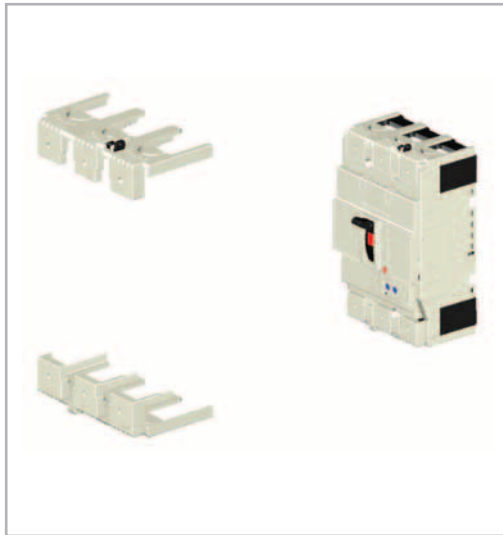

Flush Terminal Covers

Flush Terminal Covers (CS)

Flush terminal covers are available for 125A to 630A frame models and are useful for increasing the ingress protection rating at the terminals without increasing the overall length. They can be used with busbar and for direct entry of stranded cable (with cable clamp terminals (FW), refer to Section 6, Installation).

Flush terminal covers are identical to rear terminal covers for 400A and 630A frame models. The user can remove a section of the rear terminal cover using a tool to allow entry of the conductor.

Terminal covers for Rear Connection (CR)

Terminal covers for rear connection are available for 125A to 1000A frame models and may be used on MCCBs fitted with rear connections (RC) or plug-in connections (PM). They prevent access to the terminals from the front and top.

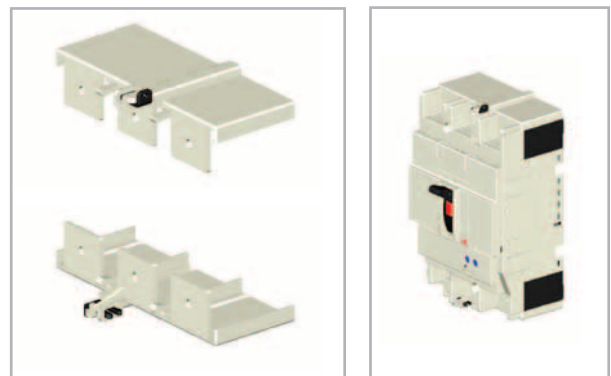

Terminal Covers for Rear Connection

ACCESSORIES

INSULATION ACCESSORIES

Interpole Barriers (BA)

Interpole barriers provide maximum insulation between phases at the terminals of the MCCB. They cannot be fitted at the same time as any of the terminal covers.

Interpole barriers for use on one end of the MCCB are supplied as standard. Additional interpole barriers can be ordered individually. All interpole barriers can easily be fitted to either end of an MCCB.

MCCB moulds have been designed to accept an additional interpole barrier between two adjacent MCCBs.

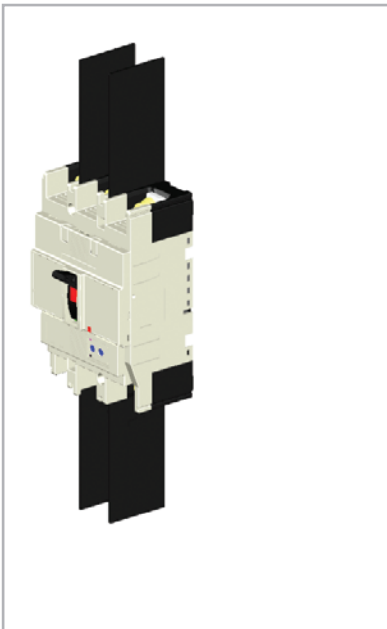

MCCB Fitted with Interpole Barriers on Both Ends

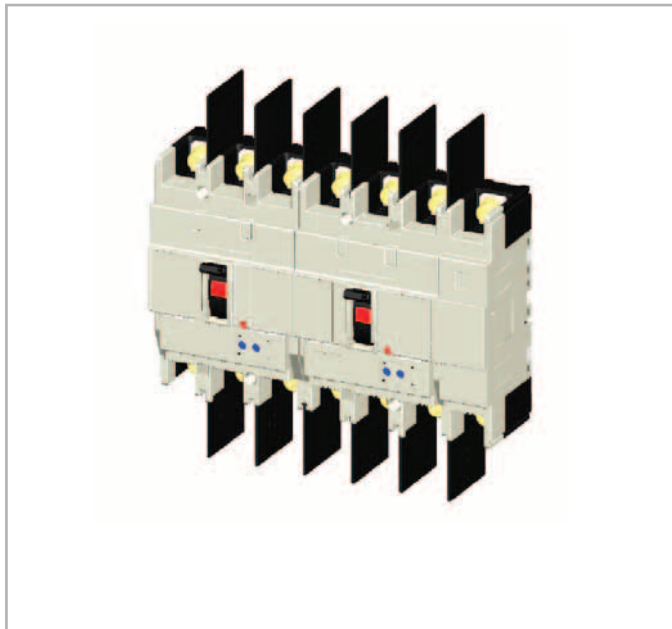

Interpole Barriers between Adjacent MCCBs

ACCESSORIES FOR DUAL SUPPLY CHANGEOVER SYSTEMS

Where more than one AC voltage source is available to a distribution system it is often necessary to prevent multiple sources supplying the system at one time. Interlocking accessories are used together with two MCCBs to prevent both being in the ON state simultaneously. This provides a secure mechanical means of preventing the connection of two supply sources.

An automatic changeover controller can monitor the status of two supplies and control the switching of two MCCBs according to pre-programmed parameters. When an automatic changeover controller is interfaced to a pair of interlocked MCCBs fitted with remote control accessories, a secure, fully automatic changeover system is achieved.

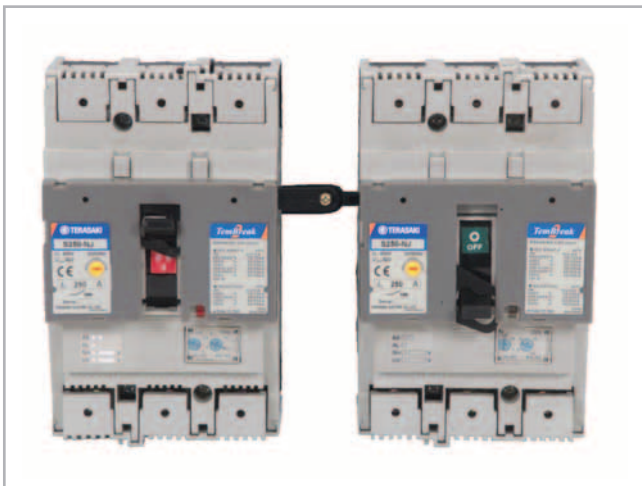

Link Interlock



Changeover Pair with Link Interlock and Motor Operators

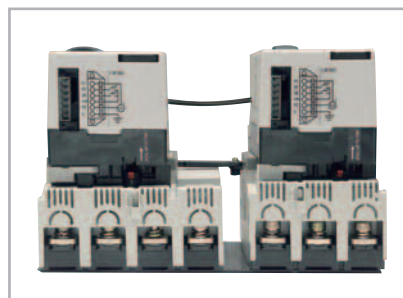

Viewed from Below

Link Interlock (ML)

Link interlocks are available for 125A to 1000A frame models and consist of a mechanism mounted to each MCCB in an adjacently mounted pair. The link between each mechanism inhibits the closure of one MCCB unless the other is in the OFF position.

Link interlocks can be used on a mixture of 3 and 4 pole breakers of the same frame size.

The TemBreak 2 link interlock is an innovative design breakthrough which will save space, time and money for switchboard builders in that:

- Installation is extremely simple. Link interlocks are field-installable and only require a screwdriver to fit. For 400A to 1000A frame models, Link interlocks are factory-fitted and available with motor operators or operating handles.
- Link interlocks replace the accessory cover on the front of the breaker
- Motor operators and operating handles are compatible with link interlocks
- The interlock is installed on the front of the MCCB and does not therefore interfere with copperwork or cables
- No need to buy factory-built backplates with MCCBs and interlocks pre-fitted

ACCESSORIES

ACCESSORIES FOR DUAL SUPPLY CHANGEOVER SYSTEMS

Wire Interlock (MW)

Wire interlocks are available for 125A to 1000A frame models and consist of two mechanisms connected by a cable. The mechanisms are mounted on two MCCBs located at a distance from each other which is limited by the length and bend radius of the cable. The mechanisms and cable inhibit the closure of one MCCB unless the other is in the OFF position. Each mechanism is ordered separately. Cables of 1.0m or 1.5m length are also ordered as separate items.

Wire interlocks can be used on a mixture of 3 and 4 pole MCCBs of different frame sizes. This allows potential cost savings by using lower rated MCCBs for the alternative power supply. MCCBs can be mounted in different switchboard compartment or on different planes.



Changeover Pair with Wire Interlock and Motor Operators

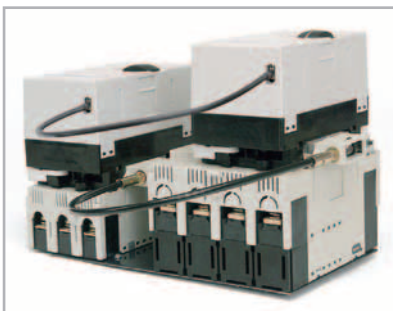

View from above

The TemBreak 2 wire interlock is an innovative design breakthrough which will save space, time and money for switchboard builders in that:

- Installation is extremely simple. Wire interlocks are field-installable. For 400A to 1000A frame models, Wire interlocks are factory-fitted and available with motor operators or operating handles.
- Wire interlocks replace the accessory cover on the front of the breaker
- Motor operators and operating handles are compatible with wire interlocks
- Interlocking of MCCBs mounted in different compartments is possible
- No need to buy factory-built backplates with MCCBs and interlocks pre-fitted

Wire interlocks are available also for 1250A and 1600A frame models. The mechanisms are mounted on the back of two MCCBs. MCCBs cannot be mounted directly to a flat plate, but are installed on a frame to ensure space for the interlock mechanism.

Slide Interlock (MS)

Slide interlocks are manually operated toggle locking devices which can be installed between two adjacent MCCBs. Depending on the position of the slide, one or other of the MCCBs on either side of a slide interlock is inhibited from being in the ON position. Slide interlocks can be used between MCCBs of the same number of poles and of the same frame size. Slide interlocks can be installed in the field and are padlockable in both positions.



Slide Interlock Installed Between two MCCBs

ACCESSORIES FOR DUAL SUPPLY CHANGEOVER SYSTEMS

TemTransfer Automatic Changeover Controller

The TemTransfer is a fully configurable **Automatic Changeover Controller (ACC)**. It is designed to monitor the incoming AC mains supply (1 or 3 phases) for under/over voltage and under/over frequency. Should these fall out of limits, the module will issue a start command to the generating set controller. Once the set is available and producing an output within limits the ACC will control the transfer devices and switch the load from the mains to the generating set. Should the mains supply return to within limits the module will command a return to the mains supply and shut down the generator after a suitable cooling run. Various timing sequences are used to prevent nuisance starting and supply breaks.

TemTransfer is compatible with TemPower 2 ACBs, TemBreak 2 MCCBs and TemContact contactors.

When TemTransfer is used with a pair of TemBreak 2 MCCBs, additional control wiring and components may be necessary for some control schemes. Contact us for details.

Terasaki can supply TemTransfer pre-configured to specification, or unconfigured with an optional interface kit.

Configuration is by PC based software and the interface kit using an FCC68 socket on the rear of the module. This allows rapid and secure configuration of the module. The FCC68 socket also provides full real-time diagnostics on the status of the ACC, its inputs and outputs.

Configuration and connection options allow for a wide range of **higher functions** such as *'Auto start inhibit'*, *'Manual restore to mains'*, *'Load inhibit'* (both mains and gen-set), *'Lamp test'*, *'Push-button transfer control'*, *'External mains'* or *'Gen-set failure inputs'*, etc.

The four position key-switch allows for mode selection:-

- Auto Mode
- Auto mode with manual return to Mains
- Run generator off load
- Run generator on load

A clear mimic diagram with 'International' symbols and LEDs provide clear indication of supply availability and load switching status. Further LED indication is provided for *'Start delay in progress'* and *'Mains return timer active'*. Two **user configurable LED's** are provided to allow the user to display specific states (defaulted to indicate that the closing procedure of the Mains or Generator circuit breaker has been started).

Five **user configurable relays** are provided to allow control of contactors, different circuit breaker types and engine control modules and alarm systems.

The controller features a self seeking power supply which will utilise power from the Mains AC supply or the Generator AC supply. A DC supply to the module is not essential for basic operation, though some 'higher' functions require it (such as system diagnostics).

The module is mounted in a robust plastic case, connection to the module is via plug and socket connectors.



TemTransfer Automatic Changeover Controller

ACCESSORIES

ACCESSORIES FOR DUAL SUPPLY CHANGEOVER SYSTEMS

Specifications

DC Supply

The TemTransfer is normally powered from the AC sensing supplies. It will only draw power from the DC supply if both AC supplies are not present.

DC power should be supplied from a low voltage supply between 8 to 35V continuous. It is able to operate at 0V for 50ms during cranking, providing supply was at least 10V before dropout and supply recovers to 5V. This is achieved without the need for internal batteries.

Maximum operating current:

150mA @ 12V, 95mA @ 24V.

Maximum standby current (AC powered supply)

34.7 mA @ 115V. 16.1mA @ 230V.

3 Low voltage auxiliary relay contacts:

8Amp DC rated 1 each: NO+NC C/O (a and b C/O contacts)

2 Mains rated relay contacts:

8Amp RMS rated 1 each NO+NC. (a and b contacts)

Dimensions:

96 x 144 x 155 DIN STANDARD.

Operating temperature range:

-15 to +55°C

Indication LED's:

Mains Available/On Load, Generator Available/On load, Start Delay, Mains Return Delay and 2 User Configurable.

Operating voltage: - Specify on ordering.

AC Voltage Input Range (for AC Powered Operation):

115V Version:- 88 - 160 V ac RMS

230V Version:- 176 - 305 V ac RMS

AC Voltage Input/Adjustment Range (Sensing Operation):

115V Version:- 55 - 152 V ac RMS

230V Version:- 110 - 304 V ac RMS

AC Frequency Input/Adjustment

Range:10 - 75 Hz

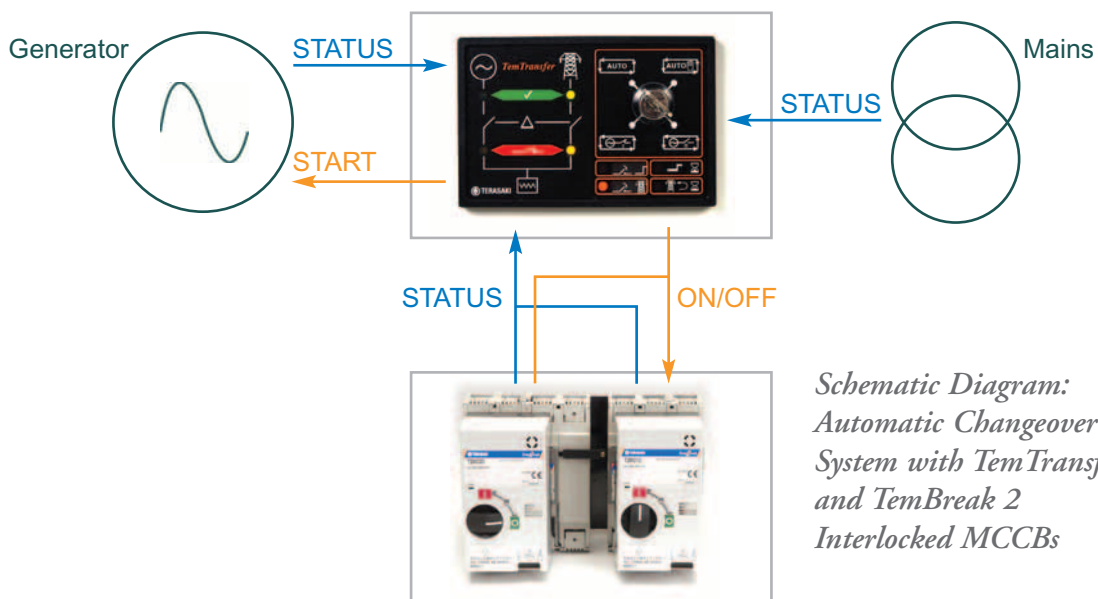

*Schematic Diagram:
Automatic Changeover
System with TemTransfer
and TemBreak 2
Interlocked MCCBs*

TEMBREAK 2

MOULDED CASE CIRCUIT BREAKERS 16A TO 1600A

1. Welcome to TemBreak 2
2. Ratings and Specifications
3. Operating Characteristics
4. Application Data
5. Accessories
6. **Installation**
 - Connection and Mounting Options and Accessories 103
 - Insulation Distances 108
 - Mounting Angle 110
 - Direction of Power Supply 110
 - Standard Installation Environment and Special Treatments 111
 - Temperature Ratings 112
7. Dimensions



INSTALLATION

CONNECTION AND MOUNTING OPTIONS AND ACCESSORIES

TemBreak 2 MCCBs connection and mounting accessories facilitate easy installation in any arrangement. Breakers and accessories are easy to fit. They are designed to provide safe and secure termination and mounting points. 125A and 160A/250A frame models have a choice of 45mm front cutout patterns

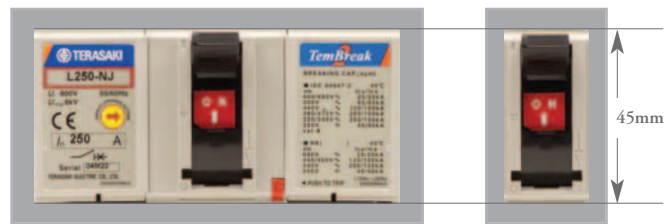

Optional 45mm Cutout Patterns

Connection and mounting options overview diagram

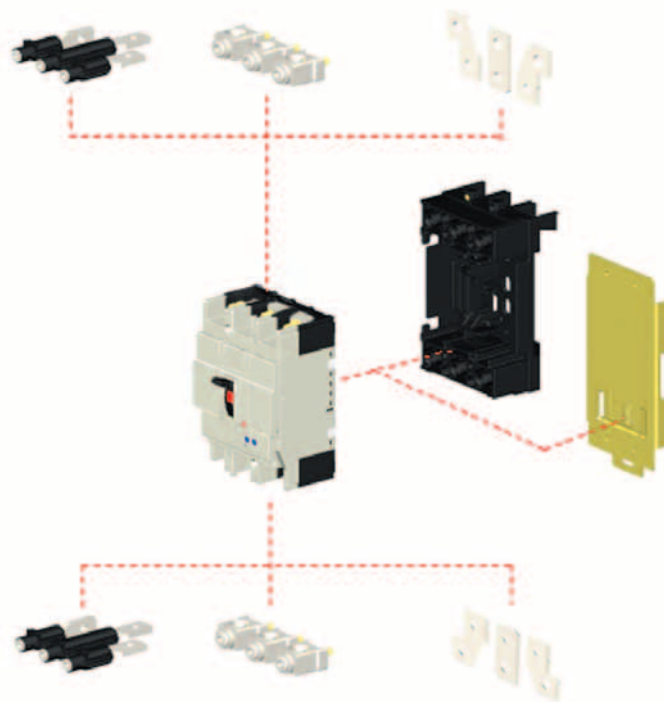

Overview of Connection and Mounting Accessories

Please refer to Section 2, Ratings and Specifications, for details of the connection and mounting options which are available for each model.

Please refer to Section 7, Dimensions, for detailed dimensions of connection and mounting options and accessories.

Note that one set of mounting screws is supplied as standard with every circuit breaker or switch disconnector purchased.

CONNECTION AND MOUNTING OPTIONS AND ACCESSORIES

Connection of Busbars and Terminated Cables

This connection method is standard for all front connected (FC) MCCB models. Solid conductors or cables terminated with crimp lug terminals can be used.

Serrated Terminal Surface

Each terminal on 160A and 250A models has a serrated surface. This provides excellent grip for heavy cables terminated with crimp lug terminals, thereby preventing sideways rotation of the lug.

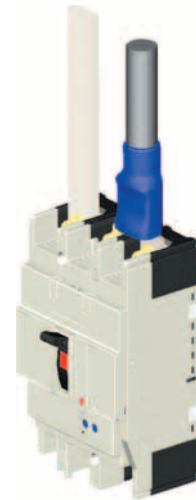
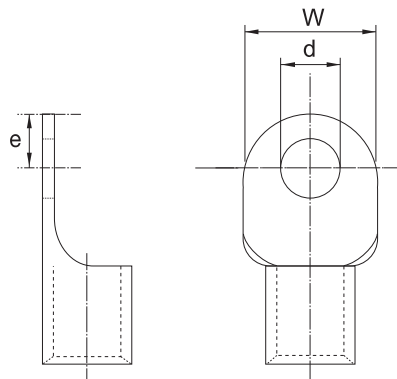

Maximum Dimensions of Compression Terminals			
Frame Size (A)	125*	160 & 250	400 & 630
Width, W (mm)	17	25	25
Diameter, d (mm)	9	9	11
Maximum from centre to tip, e(mm)	8.5	10	12

Connection of Large Conductors and Multiple Conductors

Extension bars (FB) are terminal extensions which can be fitted to line or load side terminals and are used to connect large conductors and multiple conductors. Available for field fitting in sets of 3 or 4 bars.

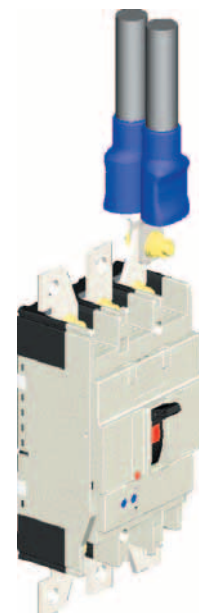

*H125 and L125 are 250A frame size

INSTALLATION

CONNECTION AND MOUNTING OPTIONS AND ACCESSORIES

Direct Entry of Stranded Cable

Cable clamp terminals (FW) can be used to secure stranded cable directly to the MCCB. Available for field fitting in sets of 3 or 4.



MCCB Model	Cable Capacity (mm ²)
E125, S125, S125-NF	1.5 to 50 (1 cable)
H125, L125, S160-NF	1.5 to 70 (1 cable)
S160, E250, S250, H250, L250	35 to 120 (1 cable)
E400, S400, H400, L400	80 to 240 (1 cable)
	60 to 120 (2 cables)

Termination in Separate Compartment

Rear connections (RC) allow termination of conductors in a different switchboard compartment to the MCCB body.

The stud can be rotated in steps of 45 degrees on a 125A to 630A frame MCCBs and 90 degrees on a 800A frame MCCBs in the field.

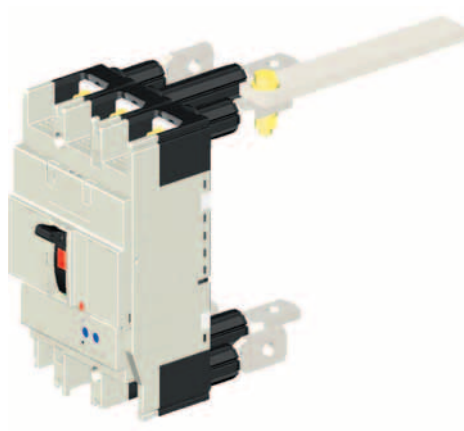

CONNECTION AND MOUNTING OPTIONS AND ACCESSORIES

Plug-in Mounting

The plug in mounting system allows fast replacement of the MCCB body without the need to disturb the terminations. Solid conductors or cables terminated with compression terminals can be used.

Plug-In Safety Lock



The plug-in MCCB body is automatically locked to the base when the contacts are closed (toggle ON). It cannot be removed unless the contacts are in the isolated position (toggle OFF or TRIPPED). This system ensures safe removal of the MCCB from the base. Plug-in safety lock is available from 125A to 800A frame models.

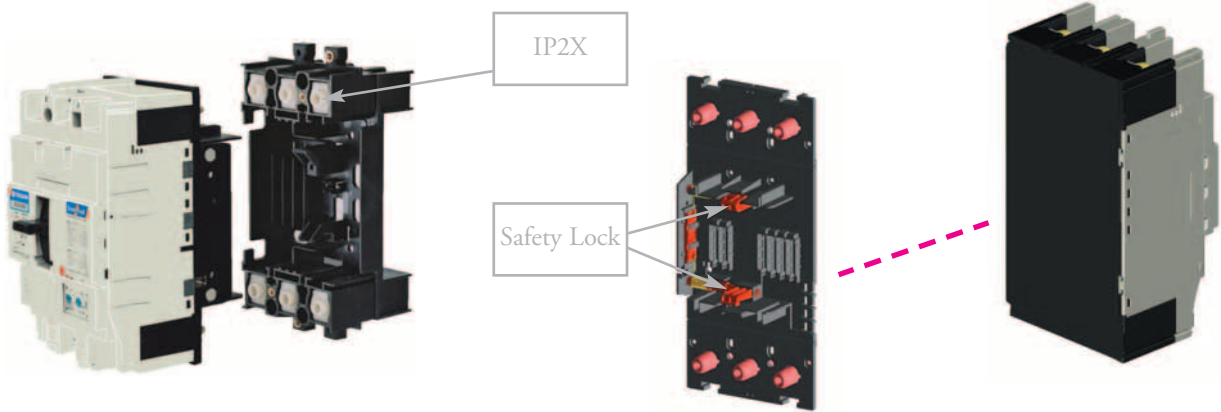

Plug-in MCCB and base

Plug-in connections and safety lock are fitted to the back of the MCCB

The connection bars for plug-in bases are optional and can be configured in the field either for front or rear access. The illustrations below show possible mounting and connection options for plug in bases. These mounting and connection options are available from 125A to 800A frame models.

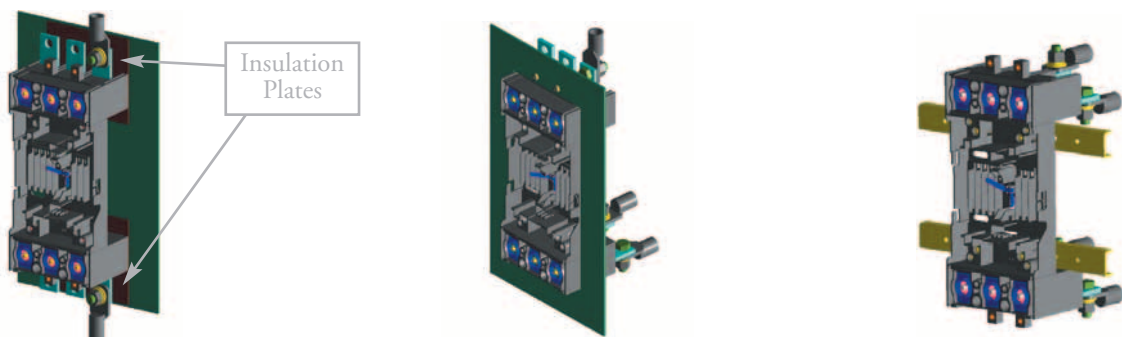

1. Mounted on base plate with connection bars mounted for front access. Insulation plates are supplied as standard and must be fitted.
2. Terminations in separate compartment. Connection bars are mounted for top access at the top and rear access at the bottom.
3. Mounted on angle bars. Connection bars are mounted for rear access.

Note: Plug-in mounting for 1250A frame model is available for only "Mounted on angle bars", and safety trip can be specified as option.

INSTALLATION

CONNECTION AND MOUNTING OPTIONS AND ACCESSORIES

Mounting on 35mm DIN Rail

The DIN rail adaptor is easily fitted to the rear of 3 pole E125 and S125 models to allow clip mounting of the MCCB to 35mm DIN rail.

The 45mm cutout of TemBreak 2 devices makes them suitable for mounting alongside modular devices in distribution boards.

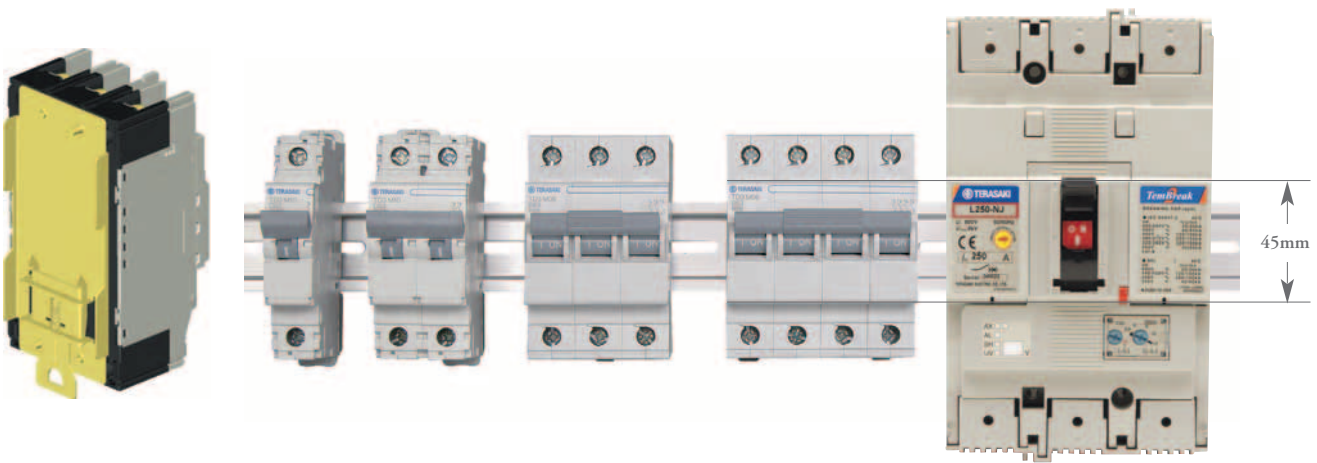

Door Flanges

A range of flanges which improves the appearance of door cutouts is available. These are suitable for toggle-operated and motor-operated MCCBs and switch-disconnectors.

INSULATION DISTANCES

The insulation distances between the MCCB and earthed metal parts and insulators shown in this section must be maintained to prevent arcing faults occurring due to conductive ionised gas. In cases where other specifications require different insulation distances to those shown here, the greater distance must be maintained. In cases where two different models are installed one above the other, the insulation distance between the two models should be as for the lower model.

ATTENTION

Exposed conductors must be insulated up to the breaker terminals. Interpole barriers or optional terminal covers are recommended. If optional terminal covers are used, insulate the exposed conductor until it overlaps the terminal cover.

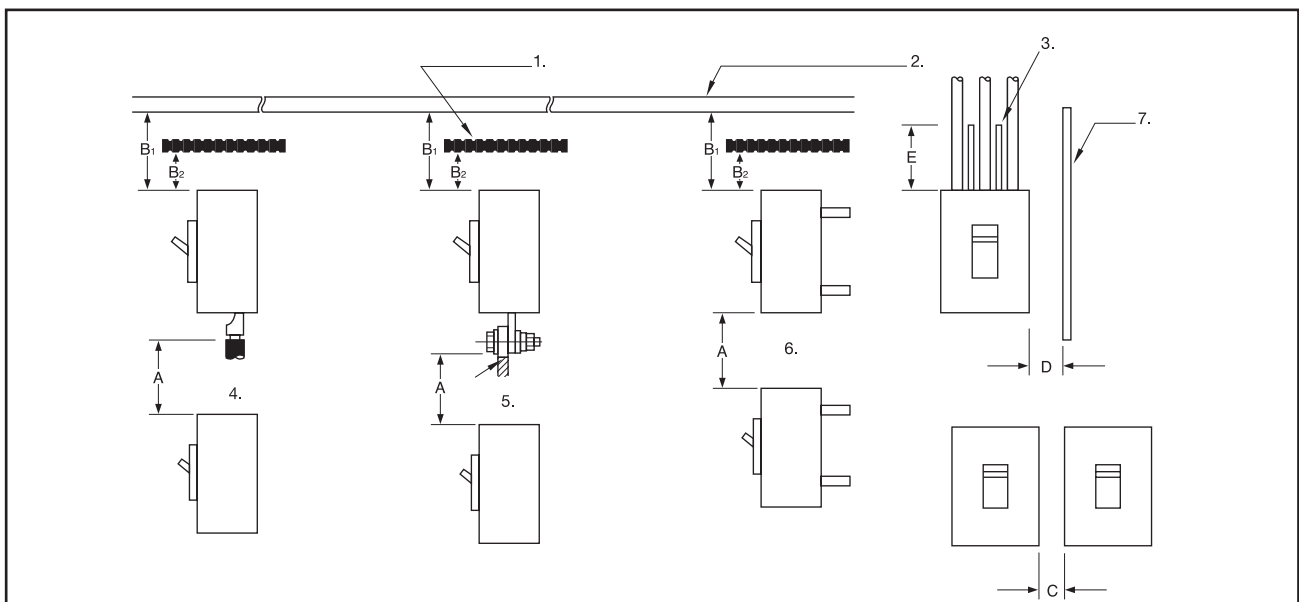

1. Insulation plate
2. Top plate (earthed metal)
3. Insulation tube or tape
4. Front-connected type
5. Front-connected type with extension bar
6. Rear-connected type, plug-in type
7. Side panel
8. A. Distance from lower breaker to exposed live part of upper breaker terminal (front-connected type) or distance from lower breaker to end face of upper breaker (rear-connected type or plug-in type)
- B1. Distance from end face of breaker to top plate
- B2. Distance from end face of breaker to insulation plate
- C. Gap between breakers
- D. Distance from side of breaker to side panel (earthed metal)
- E. Dimensions of insulation over exposed conductors

INSTALLATION

INSULATION DISTANCE IN mm (AT 690V AC MAXIMUM)

Model	Type	A	B1	B2	C	D	E
E125	NJ	50	40(2)	10	0	25	*(1)
S125	NF	50	40(2)	10	0	25	*(1)
S125	NJ	50	40(2)	10	0	25	*(1)
S125	GJ	75	45	25	0	25	*(1)
H125	NJ	100	80	60	0	50	*(1)
L125	NJ	100	80	60	0	50	*(1)
S160	NF	50	40	30	0	25	*(1)
S160	NJ	50	40	30	0	25	*(1)
S160	GJ	100	80	60	0	50	*(1)
H160	NJ	100	80	60	0	50	*(1)
L160	NJ	100	80	60	0	50	*(1)
E250	NJ	50	40	30	0	25	*(1)
S250	NJ	50	40	30	0	25	*(1)
S250	NE	50	40	30	0	25	*(1)
S250	GJ	100	80	30	0	25	*(1)
S250	GE	100	80	30	0	25	*(1)
S250	PE	100	80	60	0	50	*(1)
H250	NJ	100	80	60	0	50	*(1)
H250	NE	100	80	60	0	50	*(1)
L250	NJ	100	80	60	0	50	*(1)
E400	NJ	100	80	40	0	30	*(1)
S400	CJ	100	80	40	0	30	*(1)
S400	NJ	100	80	40	0	30	*(1)
S400	GJ	100	80	40	0	30	*(1)
S400	GE	100	80	40	0	30	*(1)
S400	PJ	100	80	40	0	30	*(1)
S400	PE	100	80	40	0	30	*(1)
H400	NE	120	120	80	0	80	*(1)
L400	NE	120	120	80	0	80	*(1)
E630	NE	120	100	80	0	80	*(1)
S630	CE	120	100	80	0	80	*(1)
S630	GE	120	100	80	0	80	*(1)
S800	CJ	120	100	80	0	80	*(1)
S800	NJ	120	100	80	0	80	*(1)
S800	NE	120	100	80	0	80	*(1)
S800	RJ	150	120	80	0	80	*(1)
S800	RE	150	120	80	0	80	*(1)
H800	NE	120(3)	120	80	0	80	*(1)
L800	NE	120(3)	120	80	0	80	*(1)
S1000	SE	150	120	80	0	80	*(1)
S1000	NE	150	120	80	0	80	*(1)
S1250	SE	150	120	80	0	80	*(1)
S1250	NE	150	120	80	0	80	*(1)
S1250	GE	150	150	100	0	100	*(1)
S1600	SE	150	150	100	0	100	*(1)
S1600	NE	150	150	100	0	100	*(1)

***Note:** (1) Insulate the exposed conductor until it overlaps the moulded case at the terminal, or the terminal cover.
 (2) 10mm at 440V AC Maximum.
 (3) Take care that arc gases are emitted to both line and load sides.

INSTALLATION

MOUNTING ANGLE

TemBreak 2 MCCBs may be mounted at any angle without affecting performance.

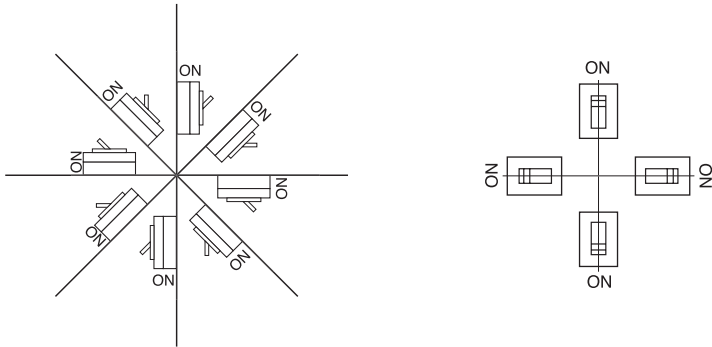

Mounting angle does not affect performance.

DIRECTION OF POWER SUPPLY

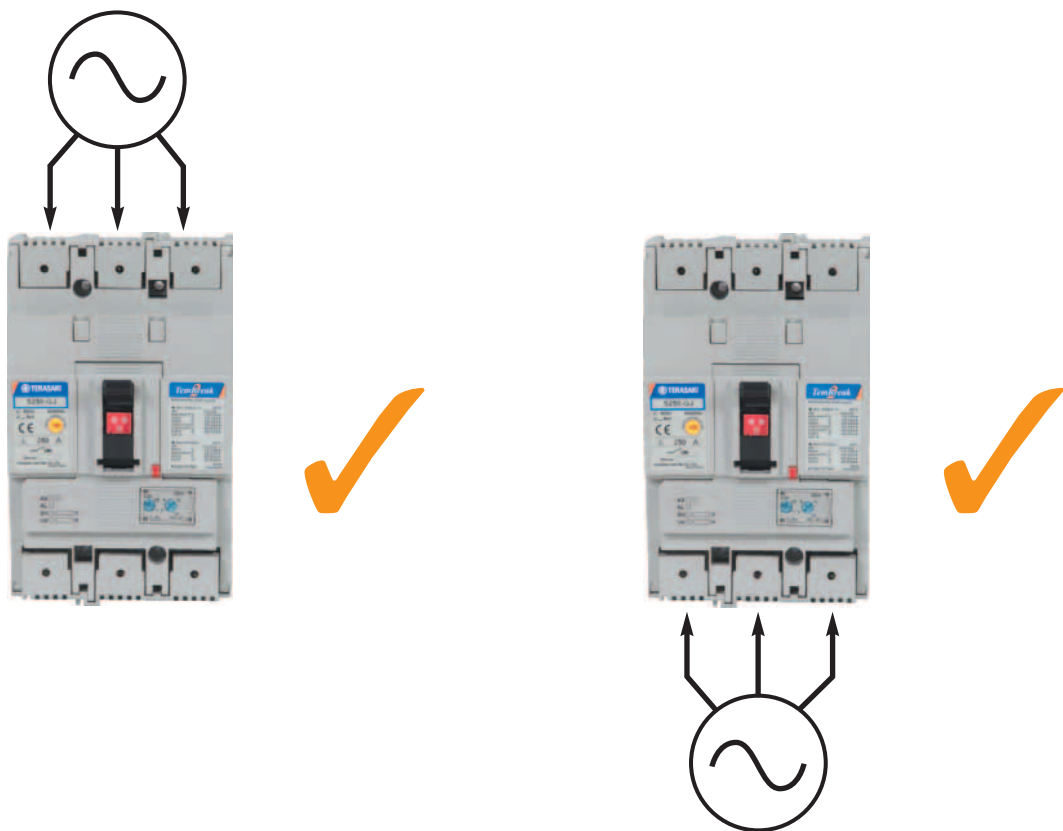

Power can be supplied through TemBreak 2 MCCBs in either direction without loss of performance.

INSTALLATION

STANDARD INSTALLATION ENVIRONMENT AND SPECIAL TREATMENTS

TemBreak 2 MCCBs are intended for installation in the following conditions as standard:

- Operating ambient temperature -10 degrees C to 45 degrees C. Refer to page 112 for thermal derating information above this temperature.
- Relative humidity of up to 85%.
- Altitude up to 2000m.
- Atmospheres free from dust, smoke, corrosive gases, inflammable gases, moisture and salt.

For installation in conditions more onerous than those described above, contact Terasaki for details.

The following special treatments have been developed for installation in specific environmental conditions:

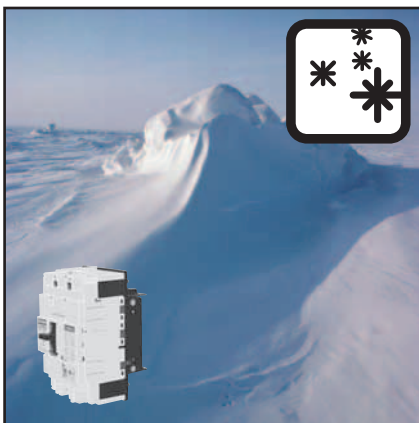

- **Low temperature treatment.** For installation at temperatures down to -40 degrees C for storage and -20 degrees C for operation. The environment must be free from rapid changes in temperature that result in the formation of condensation.



- **Fungus-moisture proofing.** For installation at temperatures up to 65 degrees C and relative humidity of up to 95%. The environment must be free from rapid changes in temperature.



- **Anti-corrosion treatment.** MCCB is surface treated to increase resistance to corrosion. If the MCCB is to be installed in atmosphere that contains excessive volumes of corrosive gases or moisture, it should be housed in an airtight enclosure.

TEMPERATURE RATINGS

Calibration Temperature: 45°C

MCCB Type	Connection Type	Rating at calibration temperature (45°C)	Rated Current (A)			
			50°C	55°C	60°C	65°C
E125-NJ S125-NJ S125-GJ	Front Rear Plug-in	20A	19	18.5	18	17.5
		32A	31	30.5	30	29
		50A	48	45	43	41
		63A	60	57	55	52
		100A	97	94	90	87
H125-NJ L125-NJ	Front Rear Plug-in	20A	19	18.5	18	17.5
		32A	31	30	29	28
		50A	48	47	45	44
		63A	61	59	57	55
		100A	97	95	92	89
S160-NJ S160-GJ	Front Rear Plug-in	20A	19	18.5	18	17.5
		32A	31	30	29	28
		50A	48	46	44	42
		63A	61	59	57	55
		100A	97	94	91	88
H160-NJ L160-NJ	Front Rear Plug-in	160A	156	151	146	141
		20A	19	18.5	18	17.5
		32A	31	30	29	28
		50A	48	46	44	42
		63A	61	59	57	55
E250-NJ S250-NJ S250-GJ	Front Rear Plug-in	100A	97	94	91	88
		125A	121	117	113	109
		160A	156	151	146	141
		250A	243	235	227	219
		20A	19	18.5	18	17.5
H250-NJ L250-NJ	Front Rear Plug-in	160A	156	151	147	143
		250A	244	237	230	223
		20A	19	18.5	18	17.5
		32A	31	30	29	28
		50A	48	46	44	42
E400-NJ S400-CJ S400-NJ S400-GJ S400-PJ	Front Rear Plug-in	400A	390	380	369	358
		250A	244	237	230	223
		630A	615	600	584	569
		800A	779	758	737	716
		20A	19	18.5	18	17.5

Calibration Temperature: 30°C

MCCB Type	Connection Type	Rating at calibration temperature (30°C)	Rated Current (A)						
			35°C	40°C	45°C	50°C	55°C	60°C	65°C
H250-NJ L250-NJ	Plug-in Conn.	250A	244	236	225	219	209	200	190

INSTALLATION

TEMPERATURE RATINGS

MCCB Type	Connection Type	Rating	Rated Current (A)								
			30°C	35°C	40°C	45°C	50°C	55°C	60°C	65°C	
S250-NE S250-GE	Front	250A	250	250	250	250	237.5	225	200	200	
	Rear										
S250-PE H250-NE	Front	250A	250	250	250	250	237.5	225	200	200	
	Rear										
S400-NE S400-GE S400-PE	Front	250A	250	250	250	250	250	250	225	200	
	Rear	400A	400	400	400	400	400	380	360	320	
H400-NE L400-NE	Front	250A	250	250	250	250	250	250	225	200	
	Rear	400A	400	400	400	400	400	380	360	320	
	Plug-in	250A	250	250	250	250	250	250	225	200	
E630-NE S630-CE S630-GE	Front	630A	630	630	630	630	630	630	598.5	567	504
	Rear*										
S800-NE S800-RE	Front	630A	630A	630A	630A	630A	630A	598.5A	567A	504A	
	Rear	800A	800A	800A	800A	800A	760A	720A	640A	504A	
H800-NE L800-NE	Front	630A	630A	630A	630A	630A	630A	598.5A	567A	504A	
	Rear	800A	800A	800A	800A	800A	720A	640A	504A	504A	
	Plug-in										
S1000-SE S1000-NE	Front	1000A	1000A	1000A	1000A	1000A	900A	800A	630A	630A	
	Rear										
S1250-SE S1250-NE S1250-GE	Front	1250A	1250A	1250A	1250A	1250A	1125A	1000A	787.5A	787.5A	
	Rear										
S1600-SE S1600-NE	Front	1600A	1600A	1600A	1600A	1600A	1520A	1440A	1280A	1008A	
	Rear										

TEMBREAK 2

MOULDED CASE CIRCUIT BREAKERS 16A TO 1600A

1. Welcome to TemBreak 2
2. Ratings and Specifications
3. Operating Characteristics
4. Application Data
5. Accessories
6. Installation
7. **Dimensions**



• S125-NE, S160-NF	115
• E125-NJ, S125-NJ, S125-GJ, S125-NN	116
• S160-NJ, S160-GJ, E250-NJ, S250-NJ, S250-GJ, S250-NN	118
• H125-NJ, L125-NJ, H160-NJ, L160-NJ, S250-NE, S250-GE, S250-PE, H250-NJ, H250-NE, L250-NJ	120
• E400-NJ, S400-CJ, S400-NJ, S400-GJ, S400-PJ, S400-NE, S400-GE, S400-PE, S400-NN	122
• H400-NE, L400-NE	124
• E630-NE, S630-CE, S630-GE, S630-NN	126
• S800-CJ, S800-NJ, S800-RJ, S800-NE, S800-RE, S800-NN	128
• H800-NE, L800-NE	130
• S1000-SE, S1000-NE, S1000-NN	132
• S1250-SE, S1250-NE, S1250-GE, S1250-NN	133
• S1600-SE, S1600-NE, S1600-NN	135
• Operating Handles	137
• Terminal Covers	149
• Interpole Barriers	152
• Terminal Blocks for Front-Connected and Rear-Connected MCCBs	153
• OCR Power Supply for Electronic Protection	
Standard type	155
With LCD	157
• Slide Interlocks	158
• Link Interlocks	163
• Wire Interlocks	169
• Position of Trip Button	176
• External Neutral CT/Door Flanges	177

DIMENSIONS

S125-NF, S160-NF

ASL: Arrangement Standard Line
 Ht: Handle Frame Centre Line

S125-NF Front connected

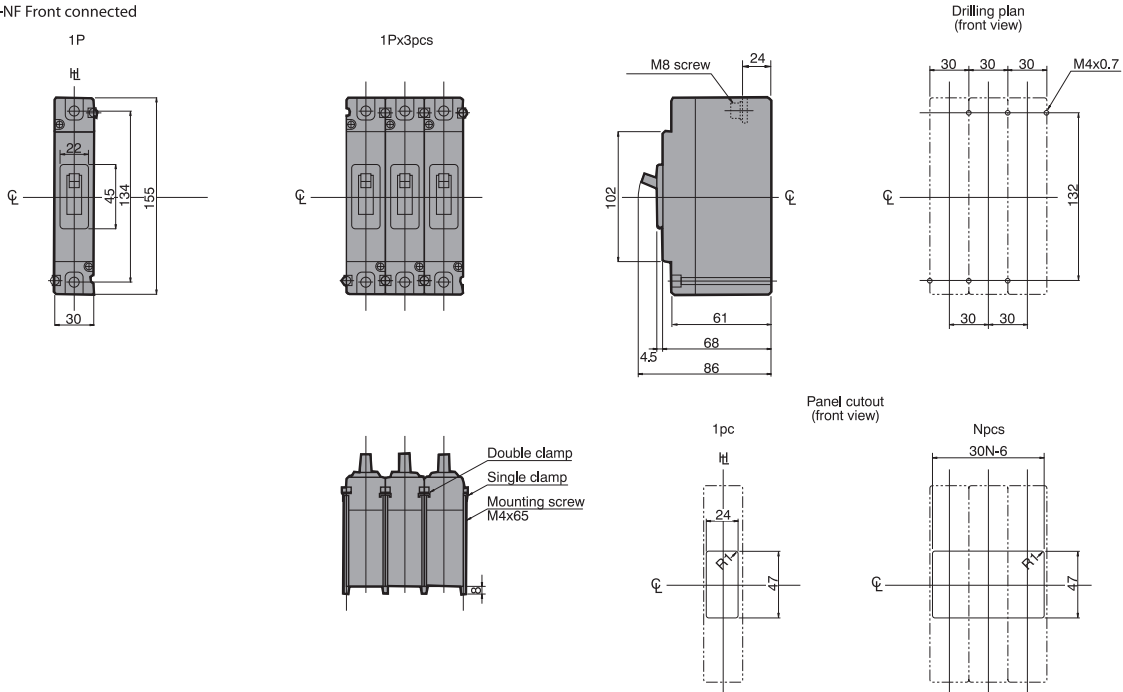

S160-NF Front connected

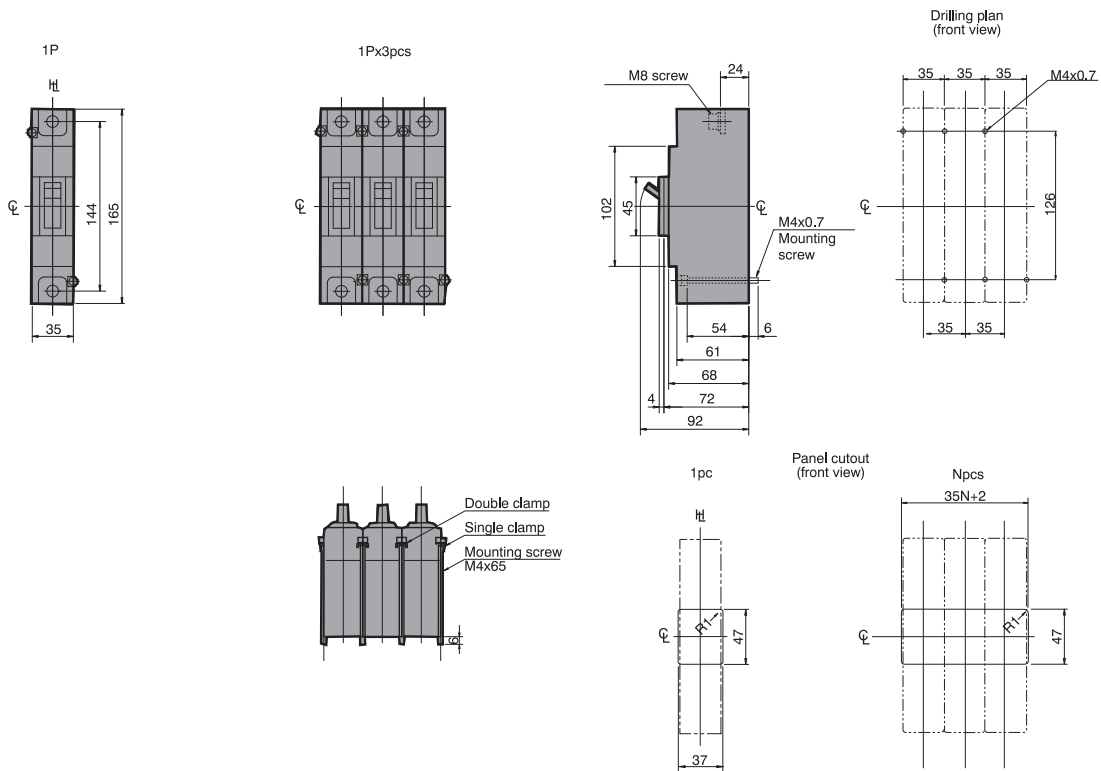

E125-NJ, S125-NJ, S125-GJ, S125-NN

ASL: Arrangement Standard Line

ht: Handle Frame Centre Line

Front connected

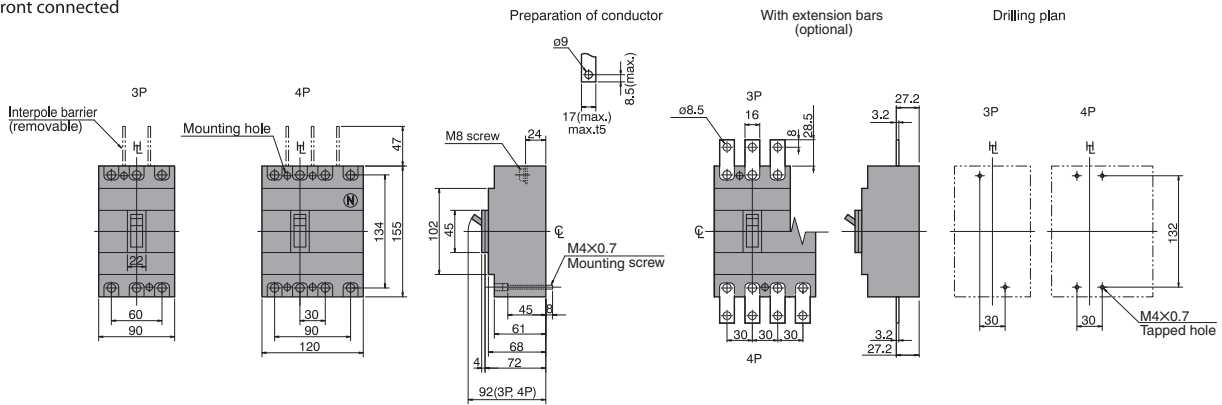

Rear connected

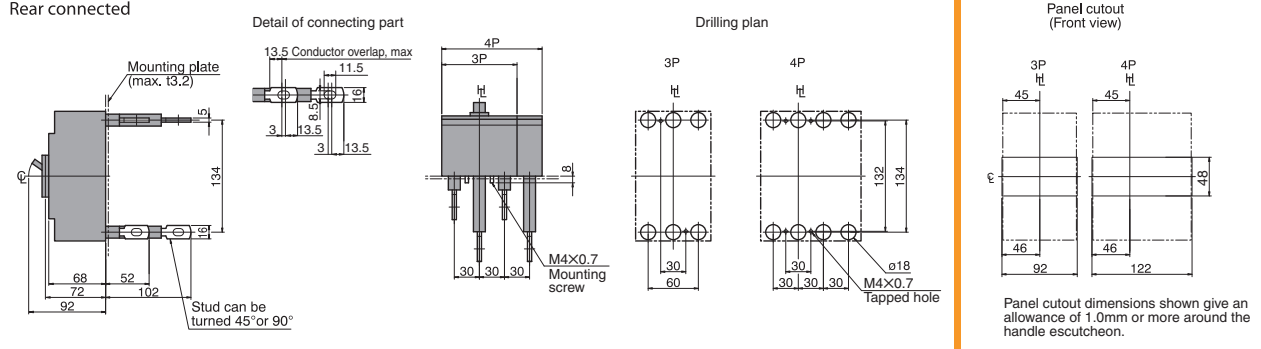

Front connected with Motor Operator

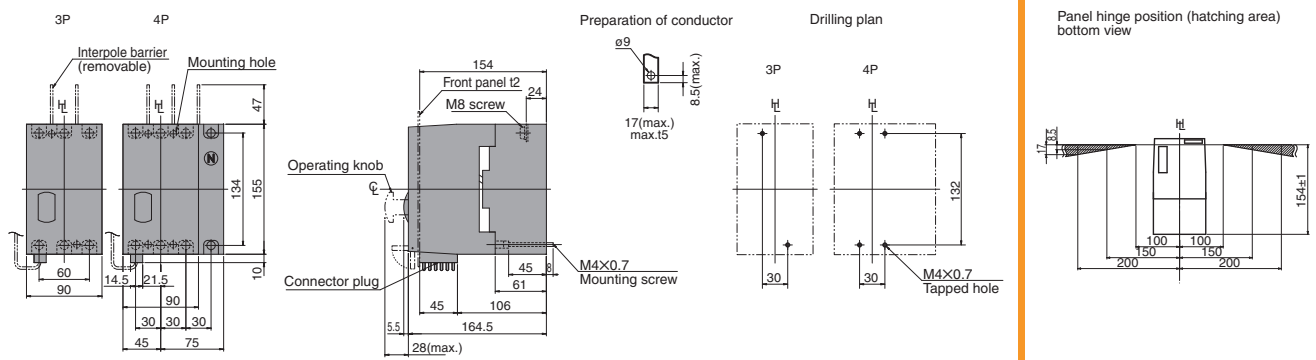

Rear connected with Motor Operator

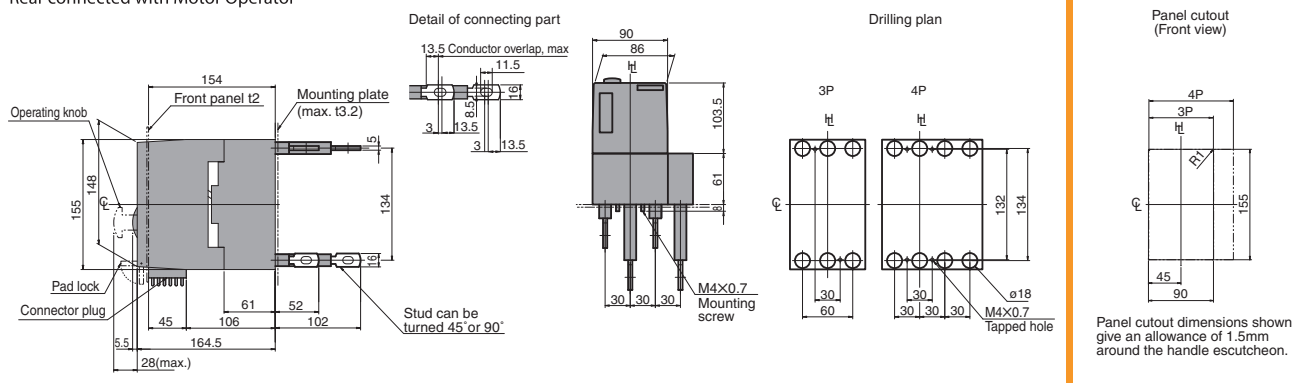

SECTION 7

DIMENSIONS

E125-NJ, S125-NJ, S125-GJ, S125-NN Plug-in Versions

ASL: Arrangement Standard Line
 HL: Handle Frame Centre Line

Outline Dimensions

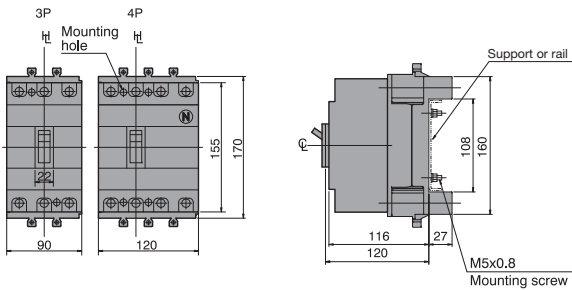

Termination of Busbar

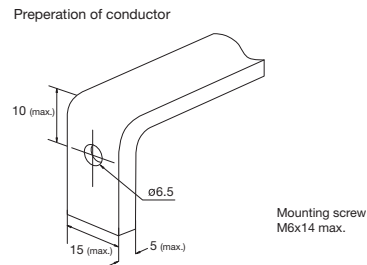

Mounting on a support or rails (shown with optional connection bars oriented for rear access)

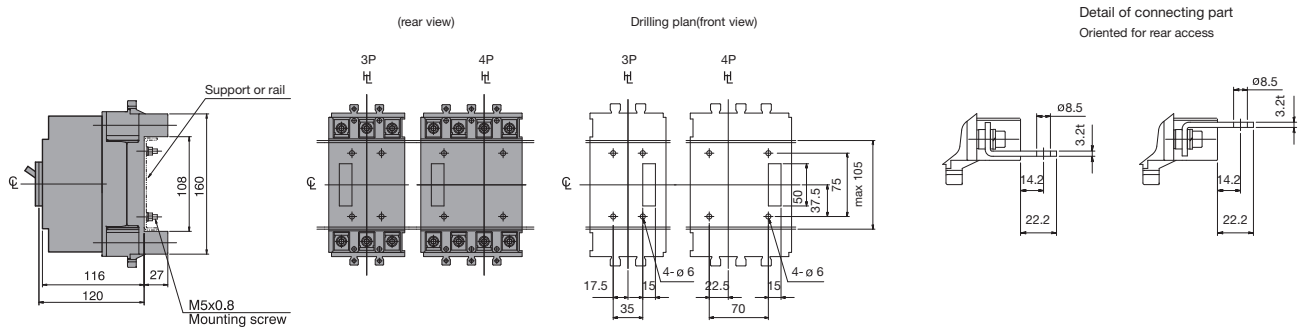

Mounting through the backplate (shown with optional connection bars oriented for rear access)

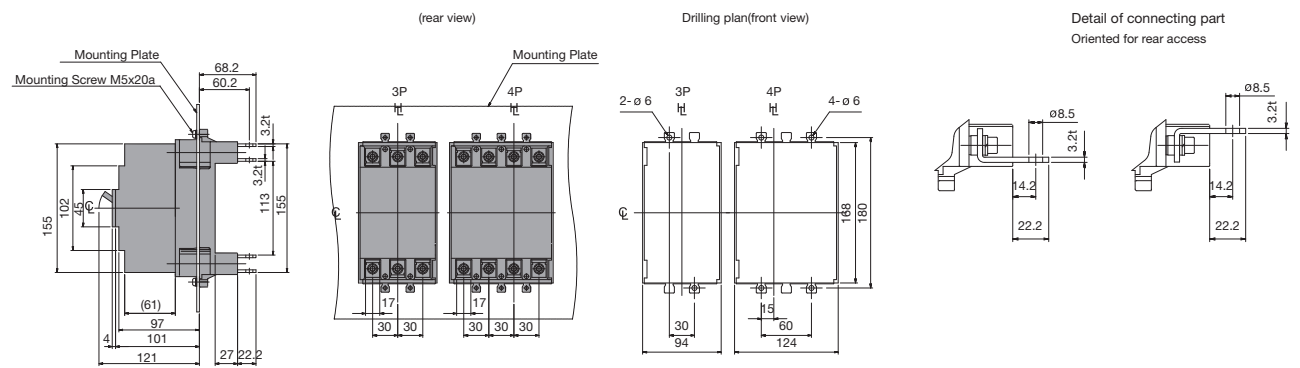

Mounting on the backplate (optional connection bars must be oriented for front access)

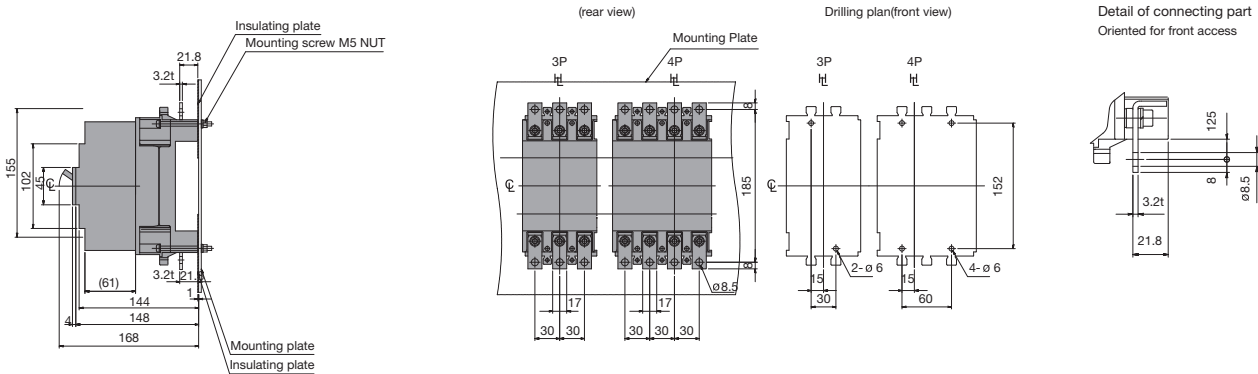

Note that the insulation plate (supplied as standard) must be fitted between the base and the backplate.

S160-NJ, S160-GJ, E250-NJ, S250-NJ, S250-GJ, S250-NN

ASL: Arrangement Standard Line
 Ht : Handle Frame Centre Line

Front connected

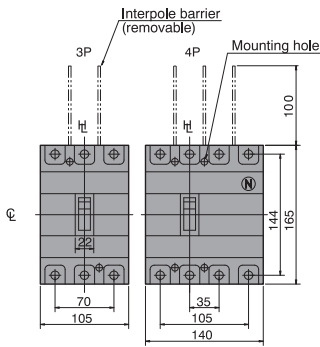

Preparation of conductor

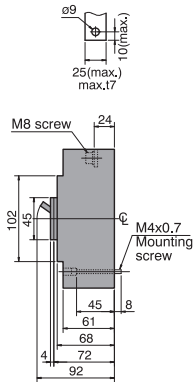

With extension bars (optional)

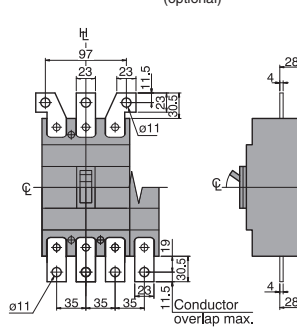

Drilling plan

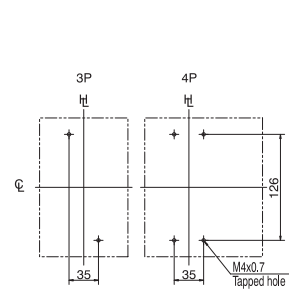

Rear connected

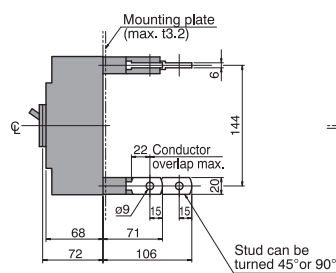

Drilling plan

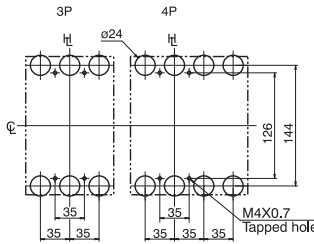

Panel cutout (Front view)

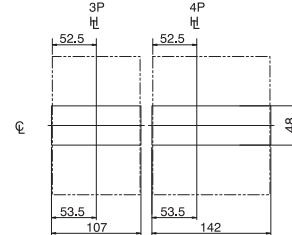

Panel cutout dimensions shown give an allowance of 1.0mm or more around the handle escutcheon.

Front connected with Motor Operator

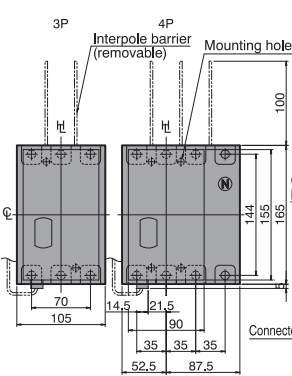

Preparation of conductor

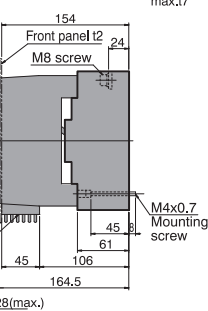

Drilling plan

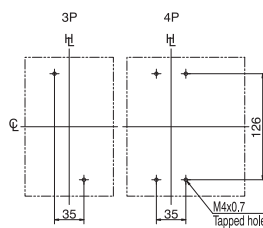

Panel hinge position (hatching area) bottom view

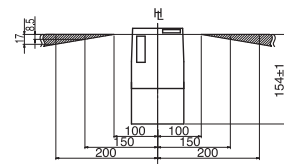

Rear connected with Motor Operator

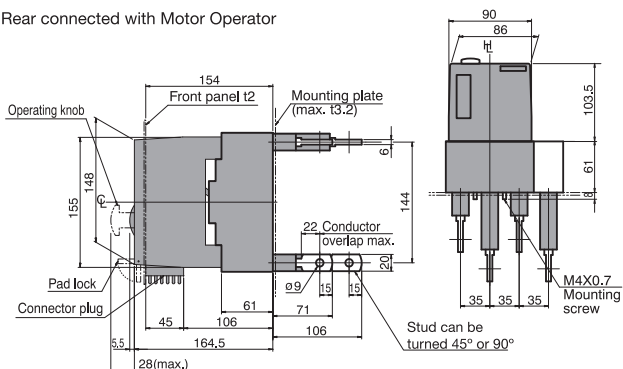

Drilling plan

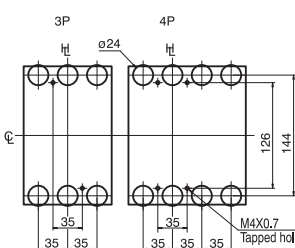

Panel cutout (Front view)

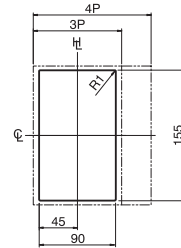

Panel cutout dimensions shown give an allowance of 1.5mm around the handle escutcheon.

DIMENSIONS

S160-NJ, S160-GJ, E250-NJ, S250-NJ, S250-GJ, S250-NN Plug-in Versions

ASL: Arrangement Standard Line

HL: Handle Frame Centre Line

Outline Dimensions

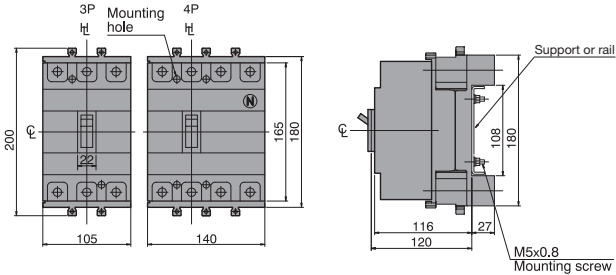

Termination of Busbar

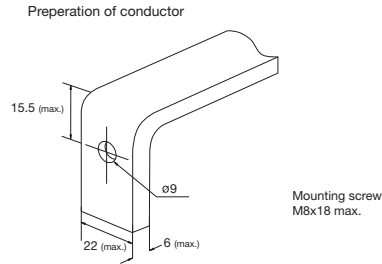

Mounting on a support or rails (shown with optional connection bars oriented for rear access)

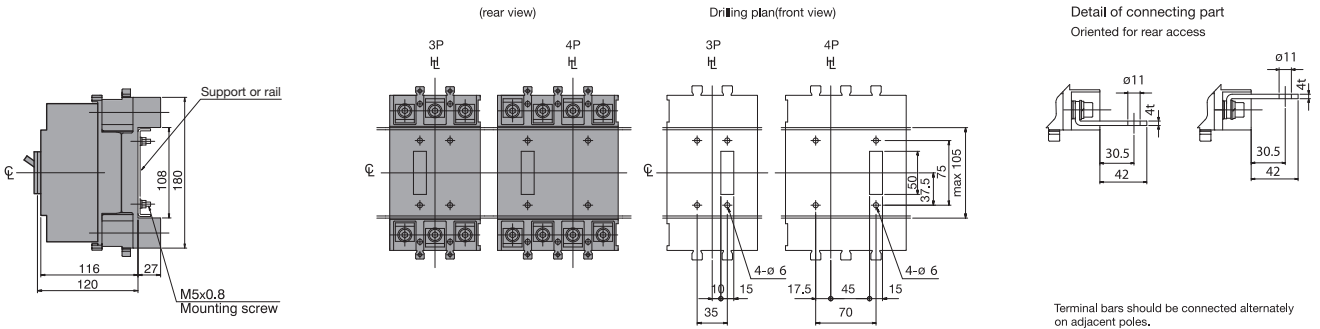

Terminal bars should be connected alternately on adjacent poles.

Mounting through the backplate (shown with optional connection bars oriented for rear access)

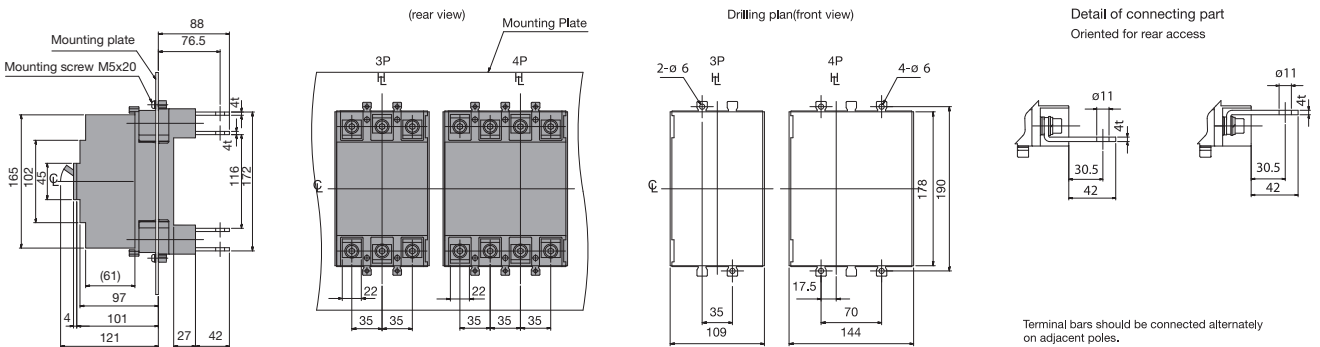

Terminal bars should be connected alternately on adjacent poles.

Mounting on the backplate (optional connection bars must be oriented for front access)

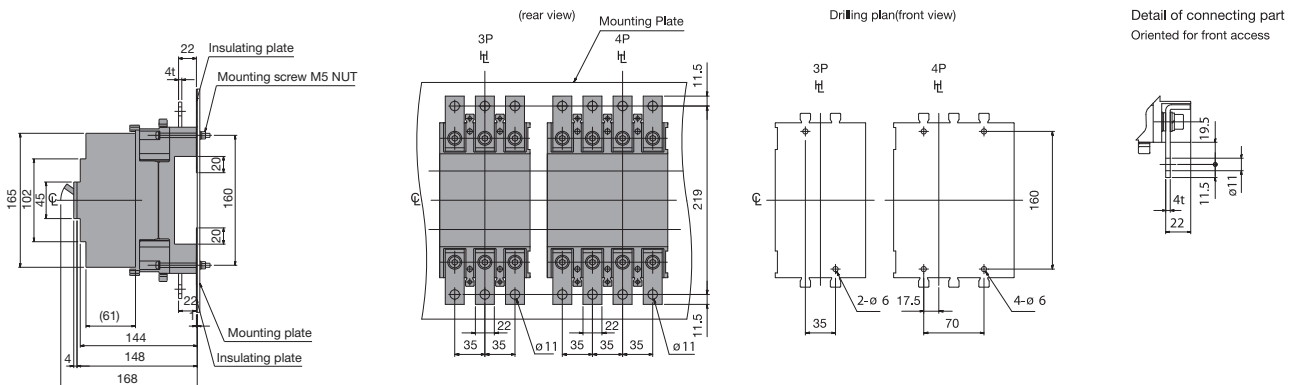

H125-NJ, L125-NJ, H160-NJ, L160-NJ, S250-NE, S250-GE, S250-PE, H250-NJ, H250-NE, L250-NJ

ASL: Arrangement Standard Line
 Ht : Handle Frame Centre Line

Front connected

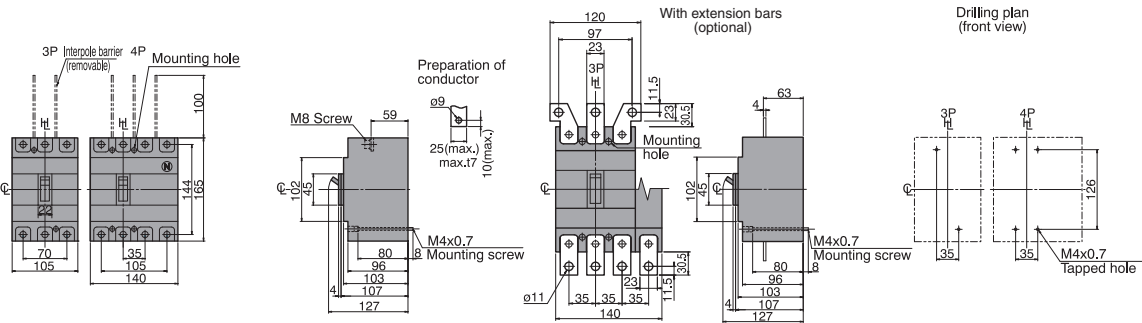

Rear connected

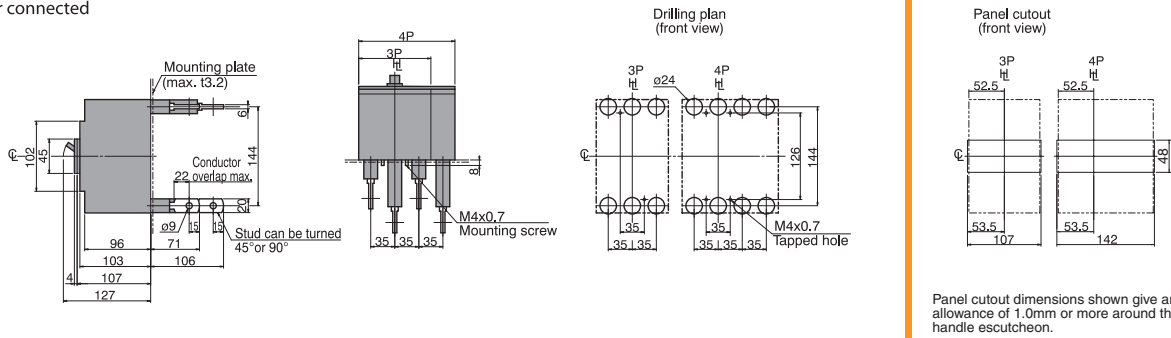

Front connected with Motor Operator

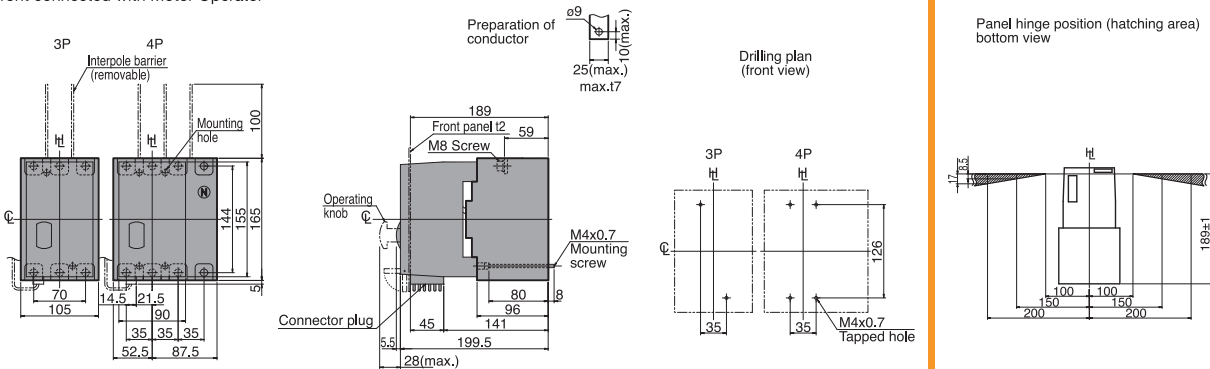

Rear connected with Motor Operator

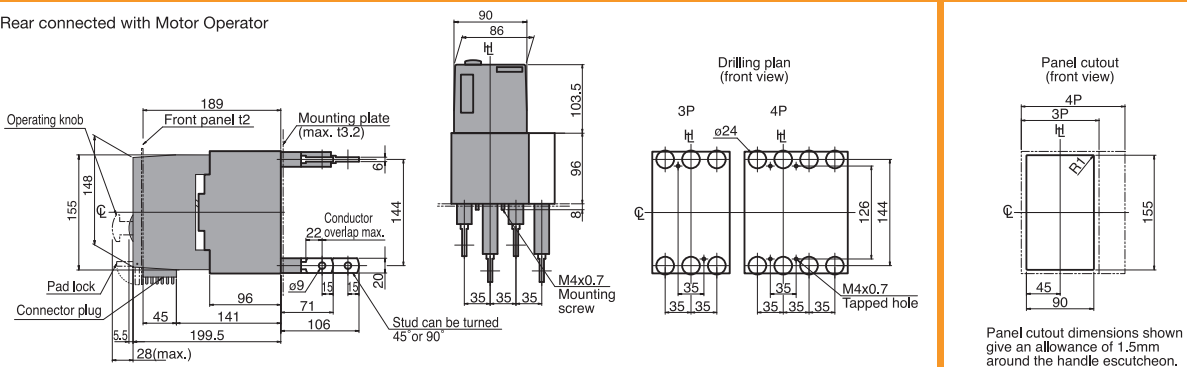

DIMENSIONS

H125-NJ, L125-NJ, H160-NJ, L160-NJ, S250-NE, S250-GE, H250-NJ, L250-NJ. Plug-in Versions

ASL: Arrangement Standard Line

HL: Handle Frame Centre Line

Outline Dimensions

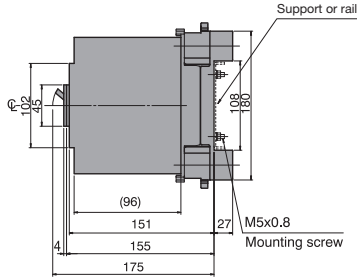
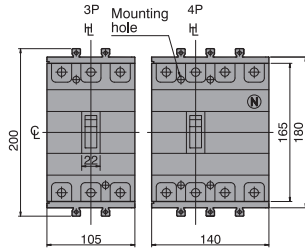

Termination of Busbar

Preparation of conductor

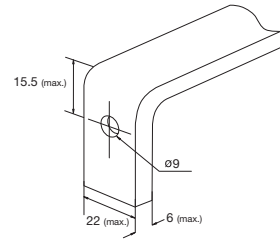

Mounting screw
M6x18 max.

Mounting on a support or rails (shown with optional connection bars oriented for rear access)

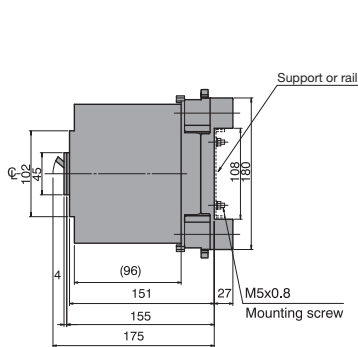

(rear view)

Drilling plan(front view)

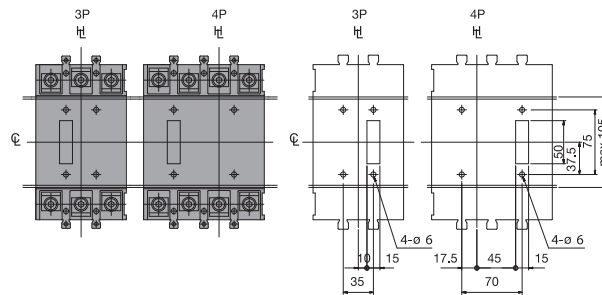

Detail of connecting part Oriented for rear access

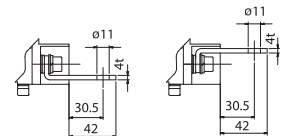

Terminal bars should be connected alternately
on adjacent poles.

Mounting through the backplate (shown with optional connection bars oriented for rear access)

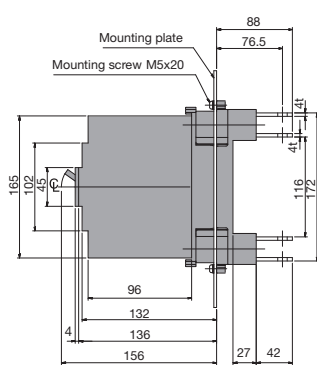

(rear view)

Drilling plan(front view)

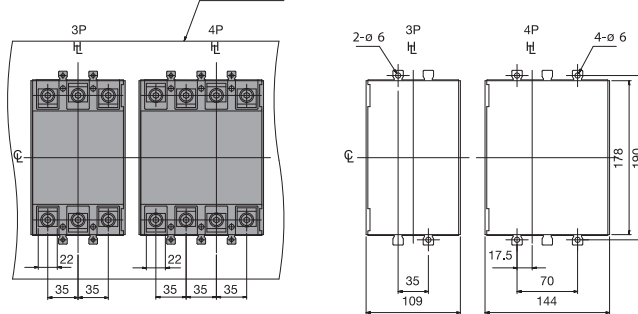

Detail of connecting part Oriented for rear access

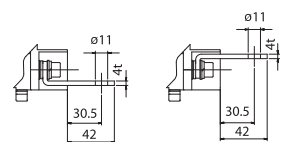

Terminal bars should be connected alternately
on adjacent poles.

Mounting on the backplate (optional connection bars must be oriented for front access)

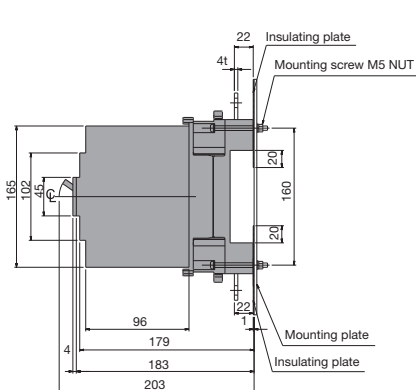

(rear view)

Drilling plan(front view)

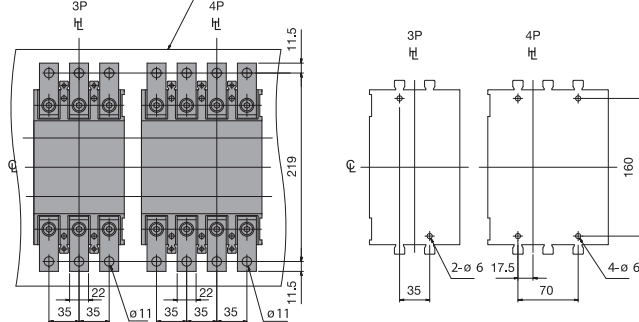

Detail of connecting part Oriented for front access

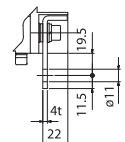

E400-NJ, S400-CJ, S400-NJ, S400-NE, S400-GJ, S400-GE, S400-PJ, S400-PE, S400-NN

ASL: Arrangement Standard Line

Ht : Handle Frame Centre Line

Front connected

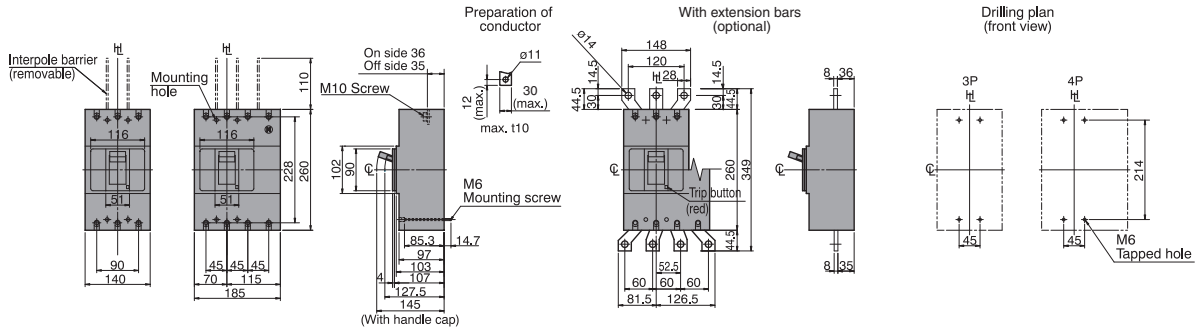

Rear connected

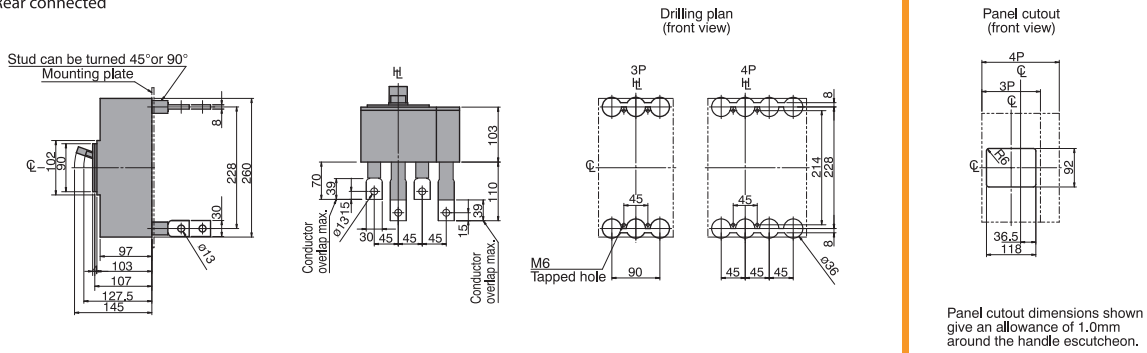

Front connected with Motor Operator

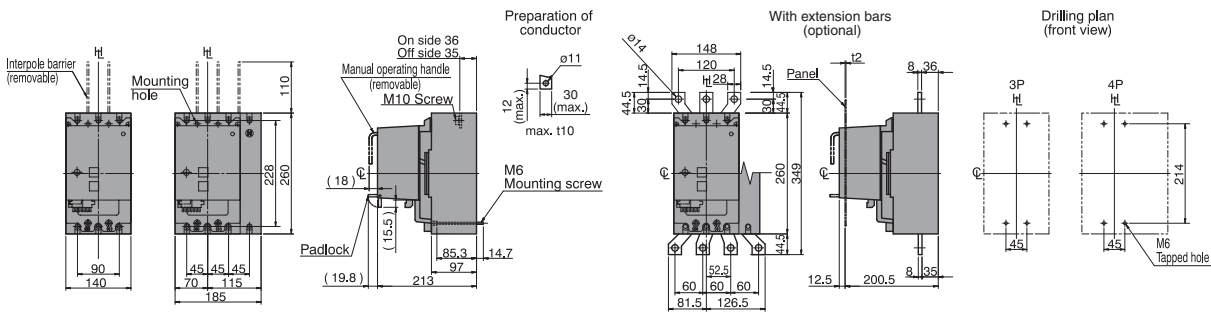

Rear connected with Motor Operator

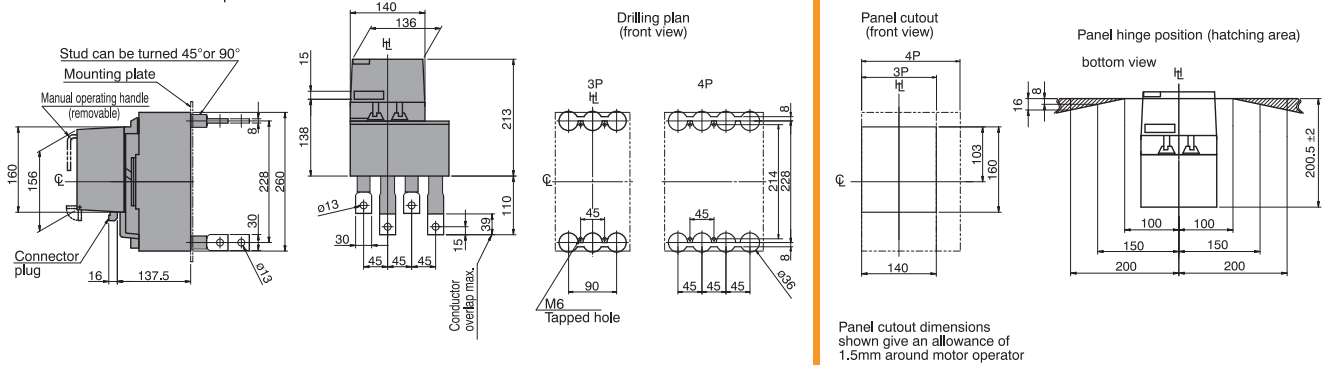

SECTION 7

DIMENSIONS

E400-NJ, S400-CJ, S400-NJ, S400-NE, S400-GJ, S400-GE, S400-PJ, S400-PE, S400-NN Plug-in Versions

ASL: Arrangement Standard Line

HL: Handle Frame Centre Line

Outline Dimensions

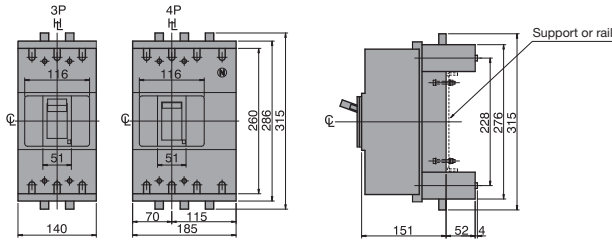

Termination of Busbar

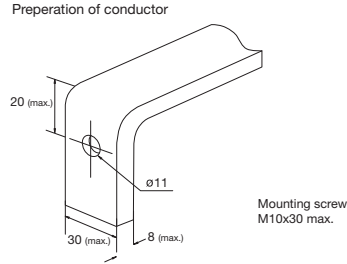

Mounting on a support or rails (shown with optional connection bars oriented for rear access)

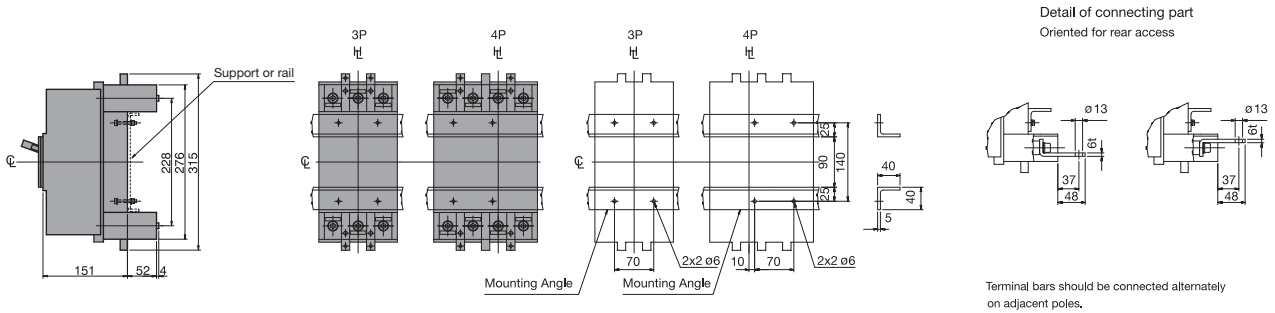

Mounting through the backplate (shown with optional connection bars oriented for rear access)

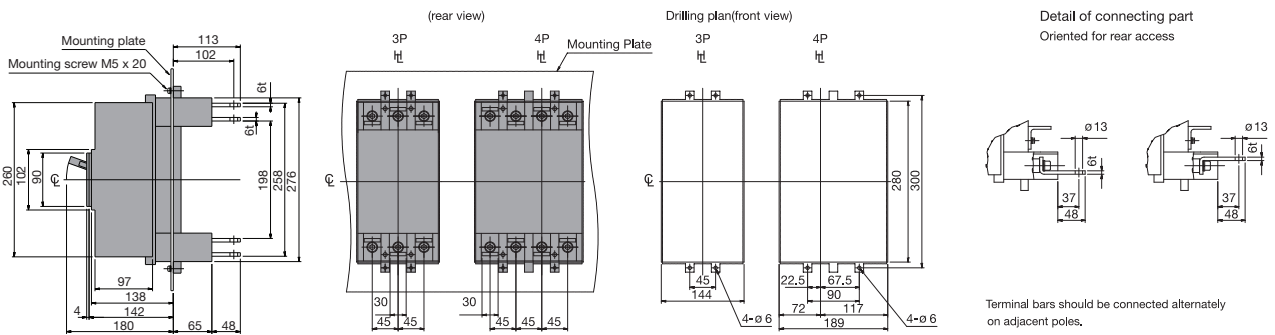

Mounting on the backplate (optional connection bars must be oriented for front access)

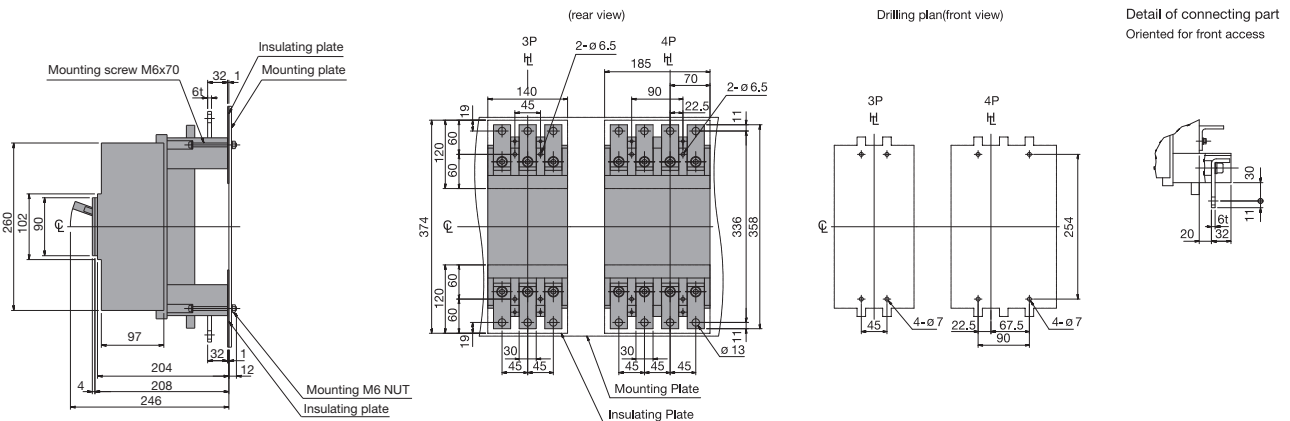

H400-NE, L400-NE

ASL: Arrangement Standard Line

ht : Handle Frame Centre Line

Front connected

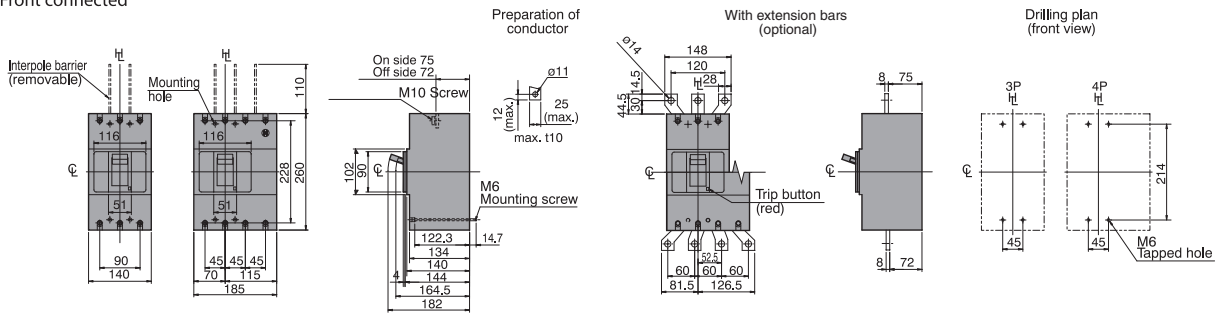

Rear connected

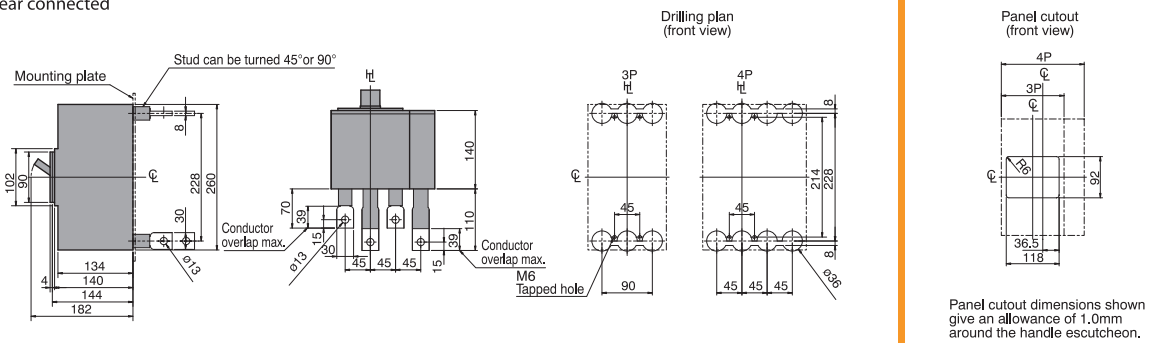

Front connected with Motor Operator

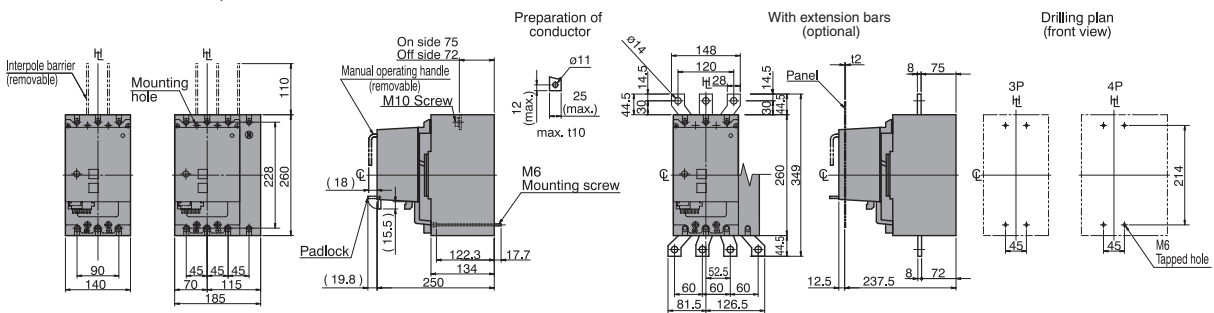

Rear connected with Motor Operator

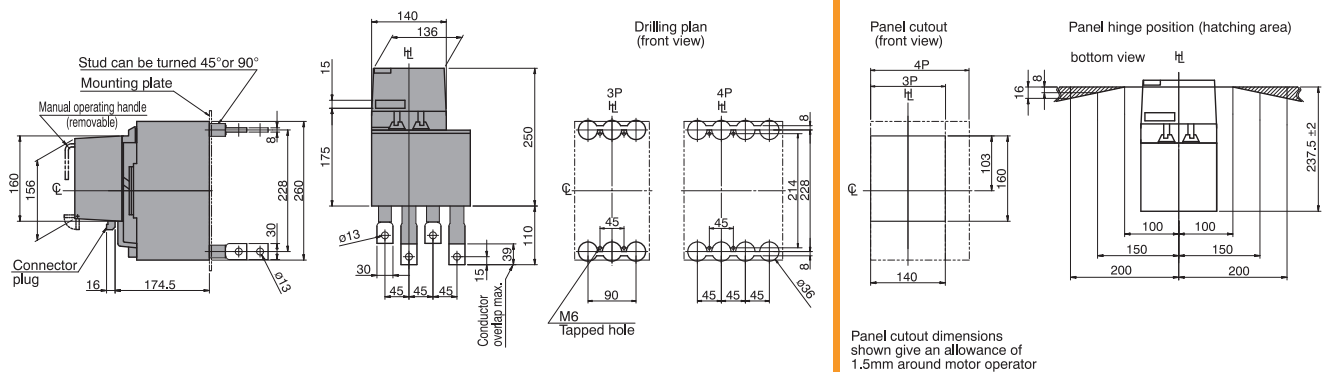

DIMENSIONS

H400-NE, L400-NE. Plug-in Versions

ASL: Arrangement Standard Line

HL: Handle Frame Centre Line

Outline Dimensions

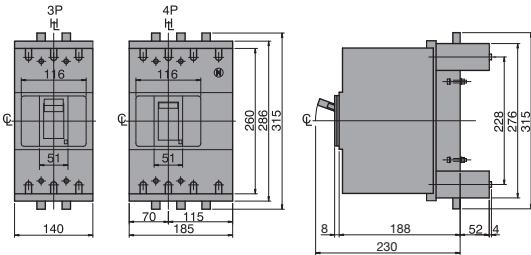

Termination of Busbar

Preparation of conductor

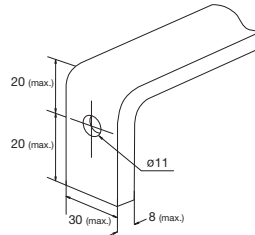

Mounting screw
M10x30 max.

Mounting on a support or rails (shown with optional connection bars oriented for rear access)

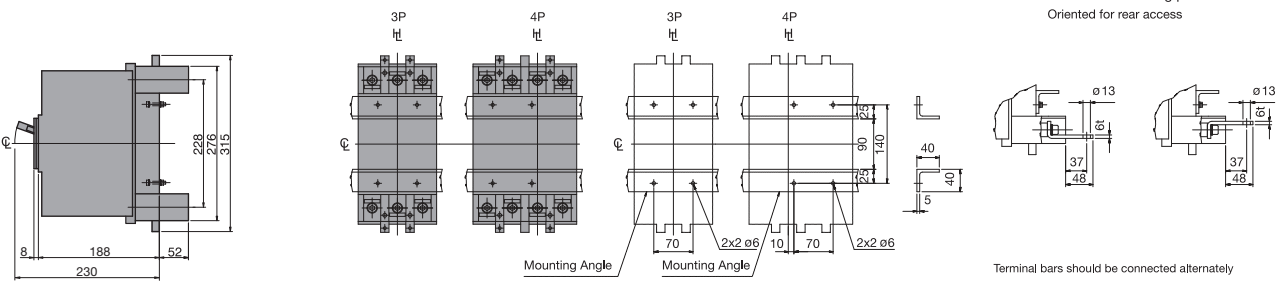

Terminal bars should be connected alternately on adjacent poles.

Mounting through the backplate (shown with optional connection bars oriented for rear access)

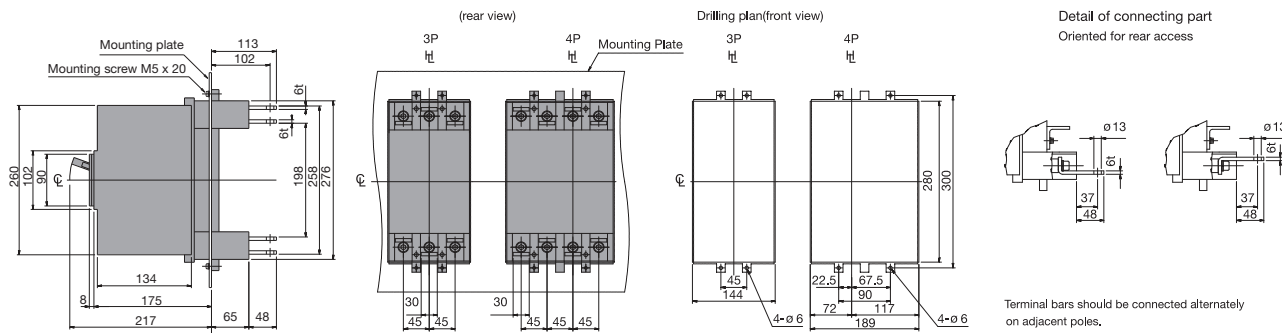

Terminal bars should be connected alternately on adjacent poles.

Mounting on the backplate (optional connection bars must be oriented for front access)

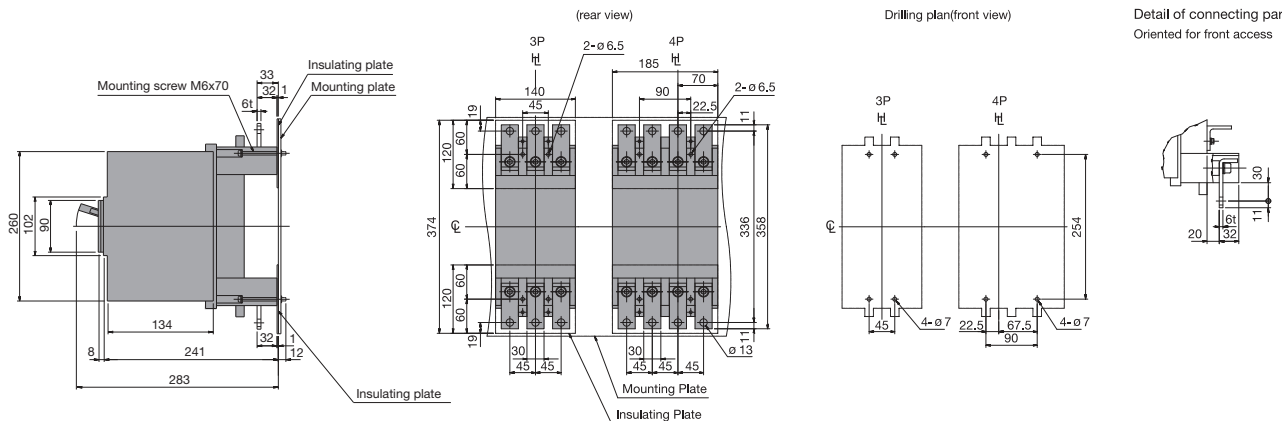

E630-NE, S630-CE, S630-GE, S630-NN

ASL: Arrangement Standard Line

Ht : Handle Frame Centre Line

Front connected

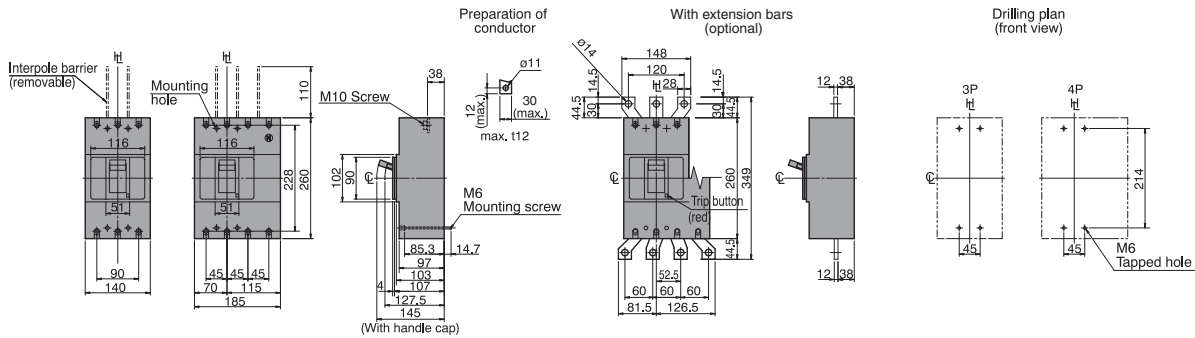

Rear connected

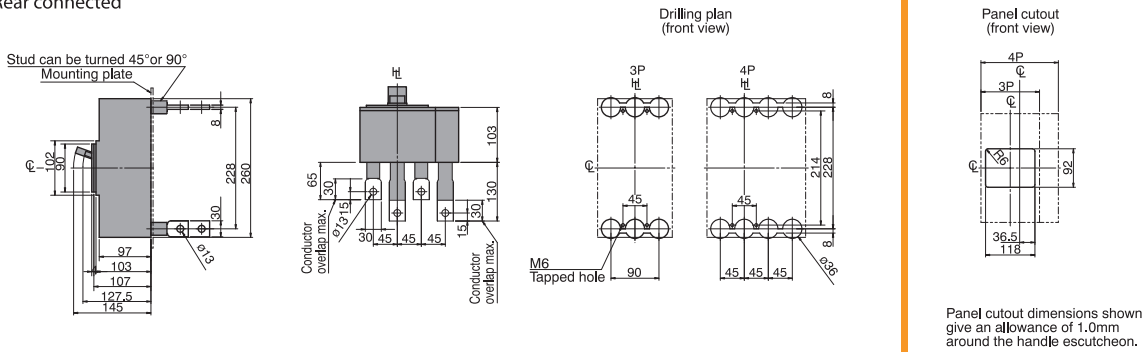

DIMENSIONS

E630-NE, S630-CE, S630-GE, S630-NN with Motor Operators

ASL: Arrangement Standard Line
 Ht: Handle Frame Centre Line

Front connected

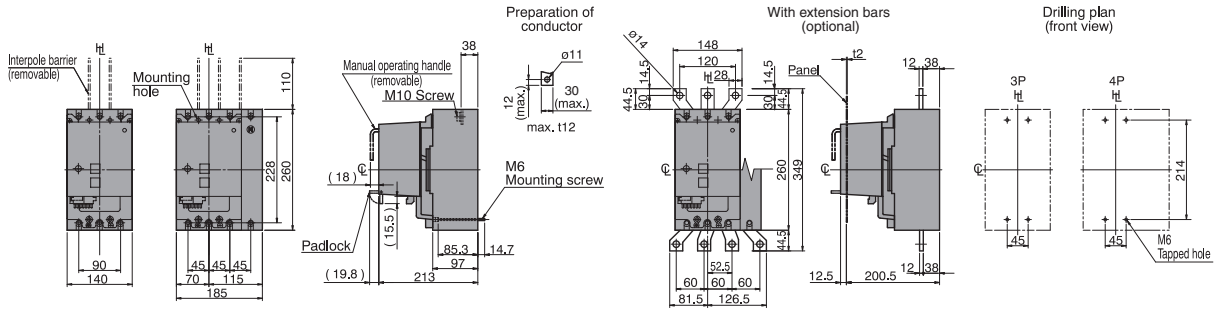

Rear connected with Motor Operator

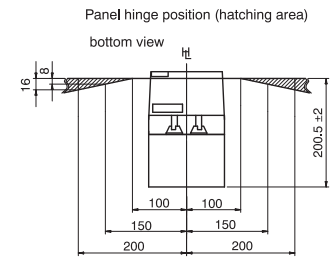
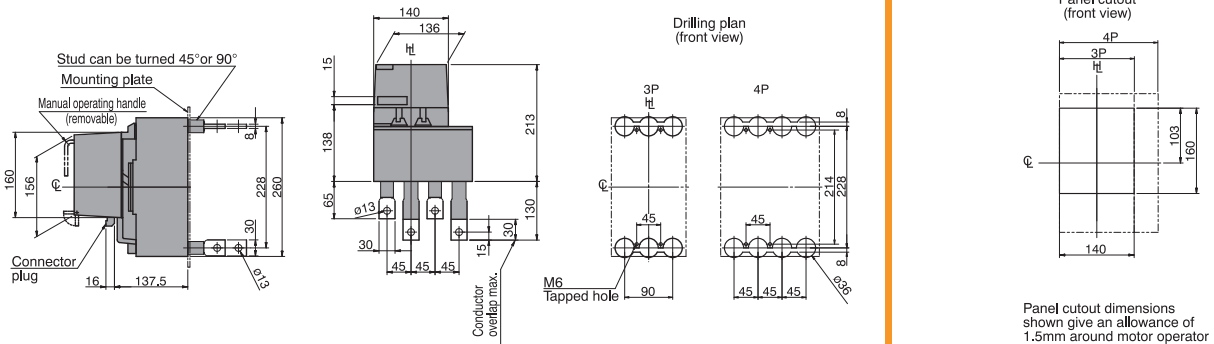

S800-CJ, S800-NJ, S800-RJ, S800-NE, S800-RE, S800-NN

ASL: Arrangement Standard Line
 HL: Handle Frame Centre Line

Front connected

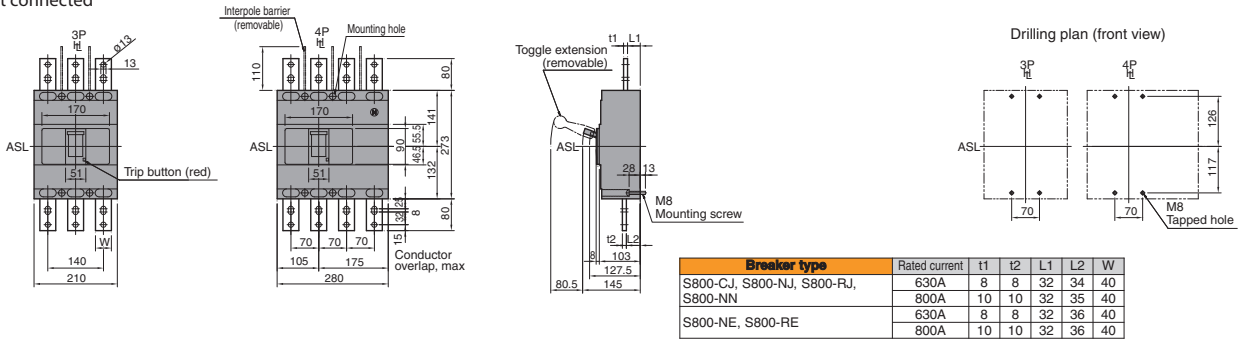

Rear connected

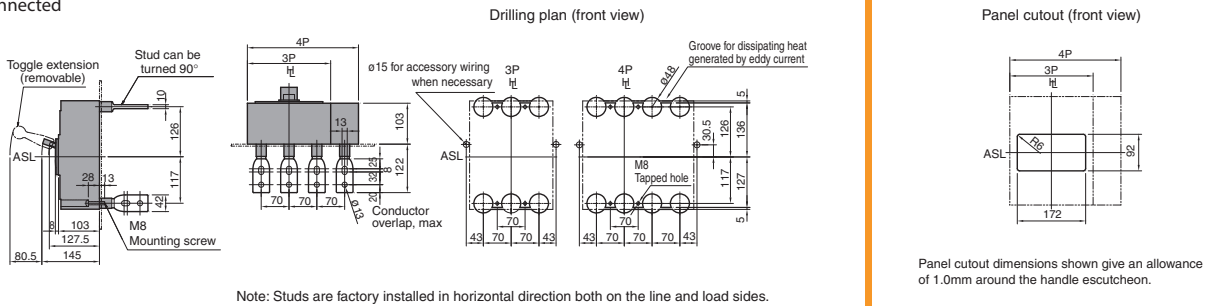

Front connected with Motor Operator

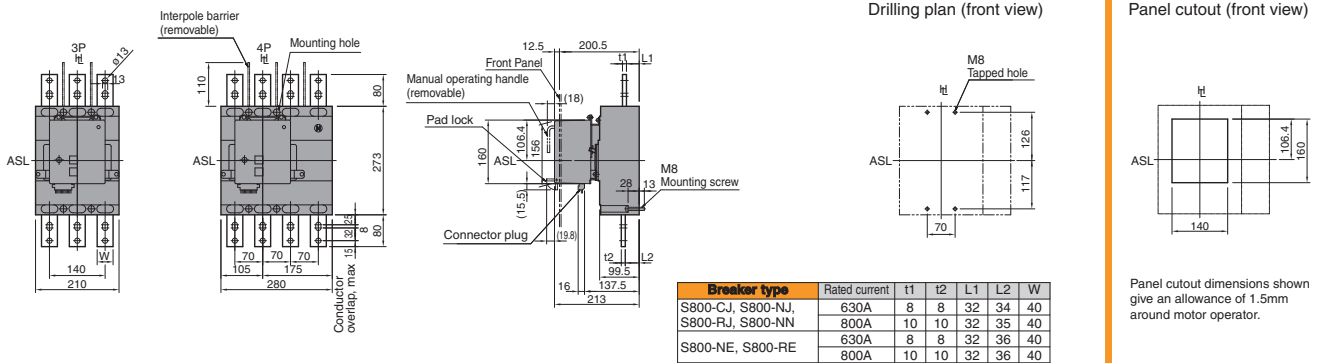

Rear connected with Motor Operator

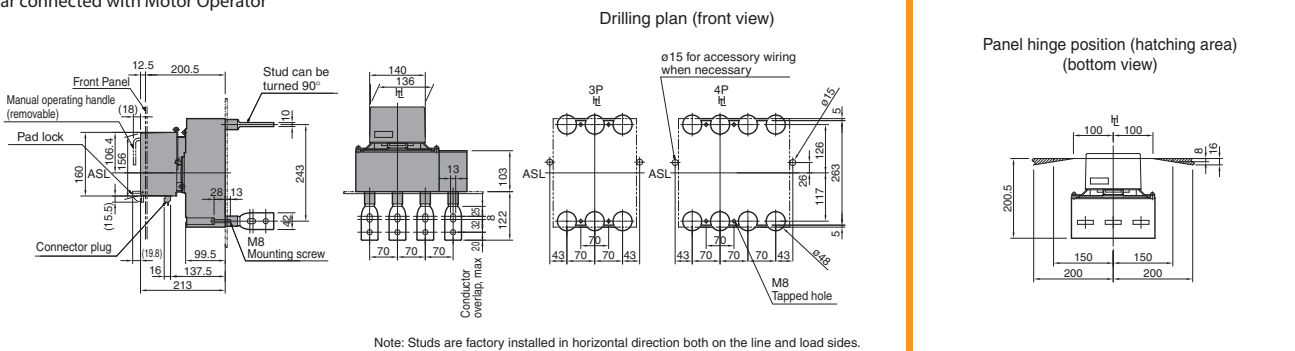

DIMENSIONS

S800-CJ, S800-NJ, S800-RJ, S800-NE, S800-RE. Plug-in Versions

ASL: Arrangement Standard Line

HL: Handle Frame Centre Line

Outline Dimensions

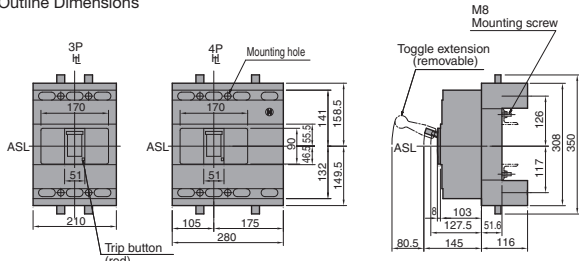

Termination of Busbar

Preparation of conductor

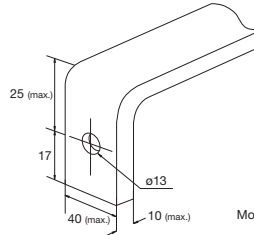

Mounting screw M12x25 max. Hex. sec. head bolt.

Mounting on a support or rails

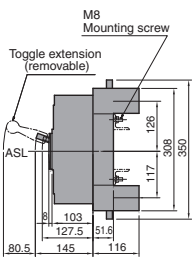

Mounting base (rear view)

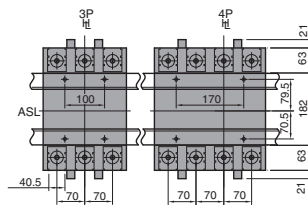

Drilling plan (front view)

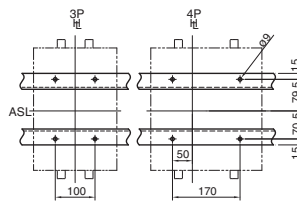

Detail of connecting part Oriented for rear access

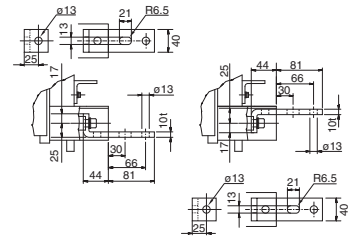

Terminal bars should be connected alternately on adjacent poles.

Mounting through the backplate (shown with optional connection bars oriented for rear access)

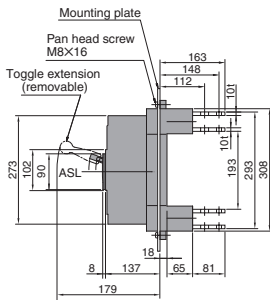

(rear view)

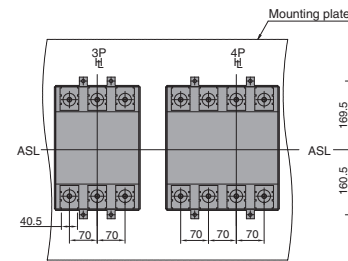

Drilling plan (front view)

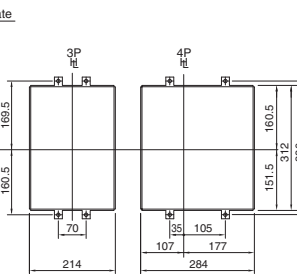

Detail of connecting part Oriented for rear access

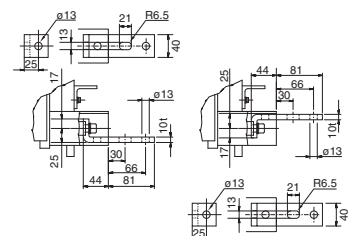

Terminal bars should be connected alternately on adjacent poles.

Mounting on the backplate (optional connection bars must be oriented for front access)

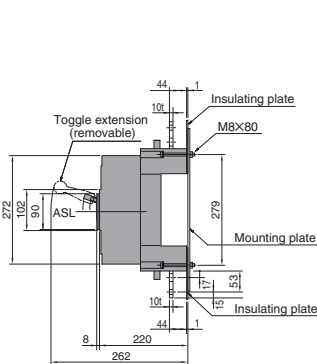

(rear view)

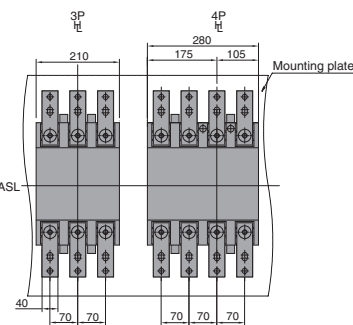

Drilling plan (front view)

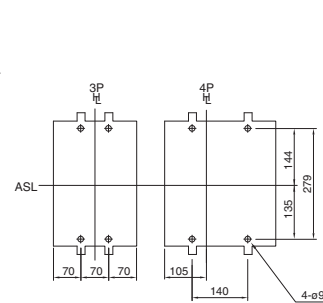

Detail of connecting part Oriented for front access

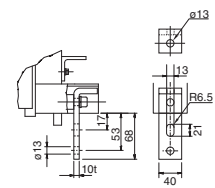

H800-NE, L800-NE

ASL: Arrangement Standard Line
 H: Handle Frame Centre Line

Front connected

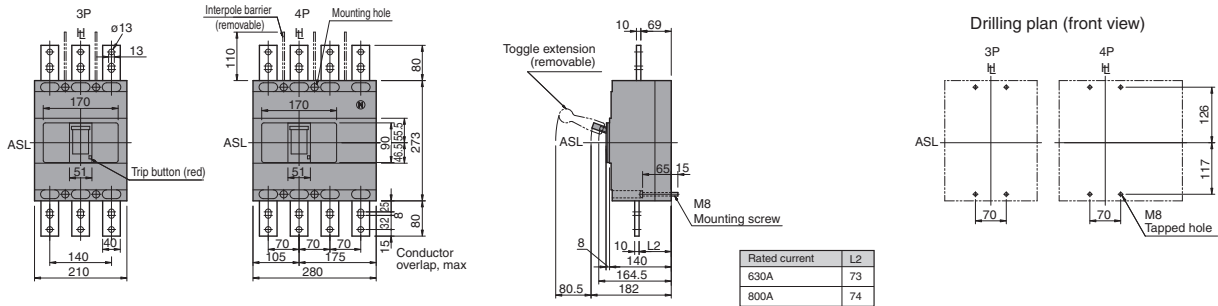

Rear connected

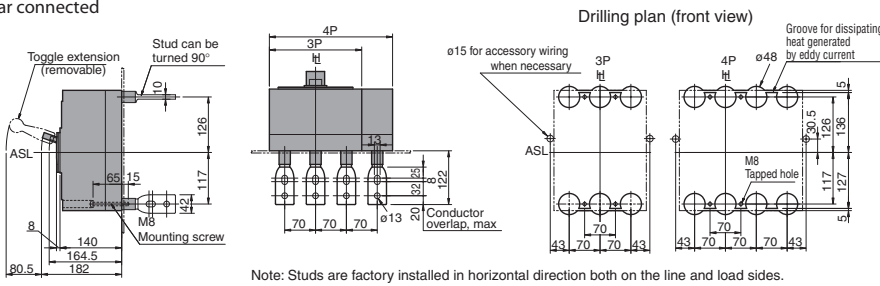

Panel cutout (front view)

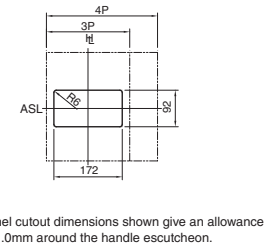

Front connected with Motor Operator

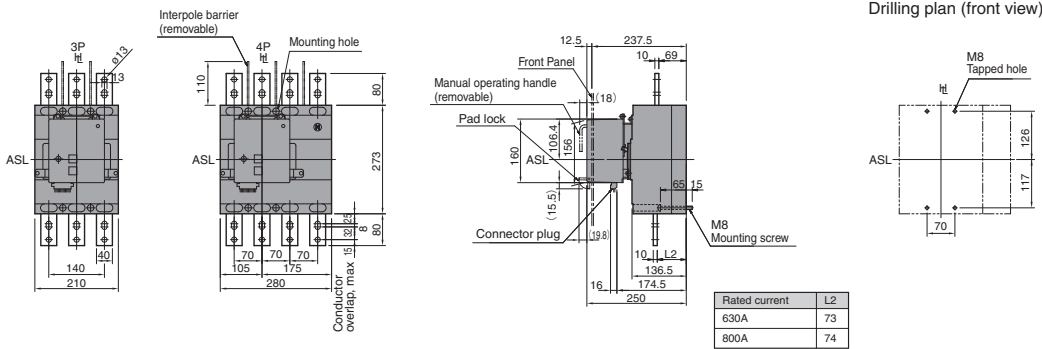

Panel cutout (front view)

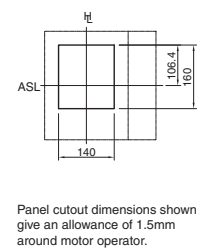

Rear connected with Motor Operator

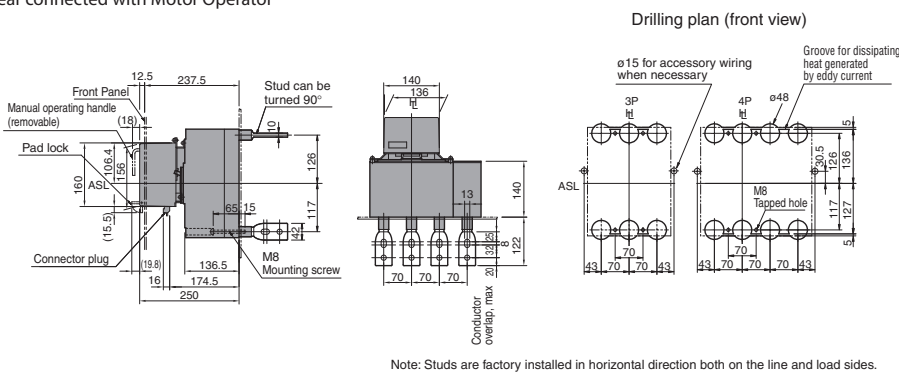

Panel hinge position (hatching area) (bottom view)

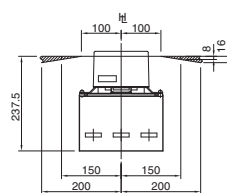

DIMENSIONS

H800-NE, L800-NE. Plug-in Versions

ASL: Arrangement Standard Line
 H_L: Handle Frame Centre Line

Outline Dimensions

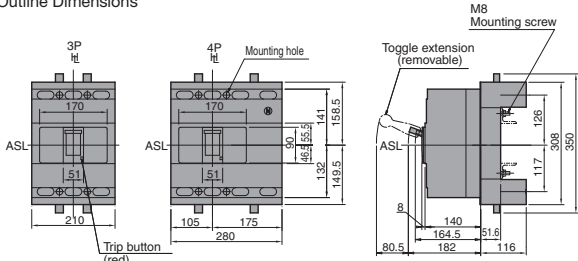

Termination of Busbar

Preparation of conductor

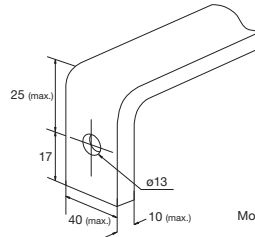

Mounting screw M12x25 max. Hex. sec. head bolt.

Mounting on a support or rails

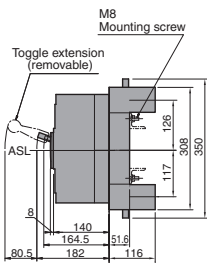

Mounting base (rear view)

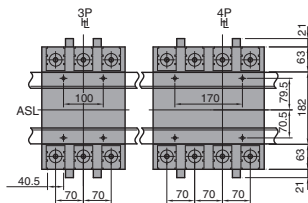

Drilling plan (front view)

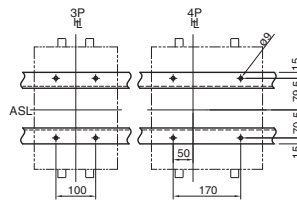

Detail of connecting part Oriented for rear access

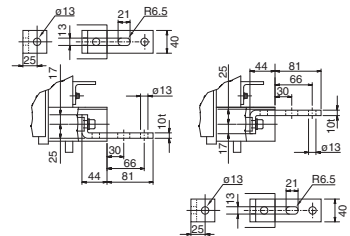

Terminal bars should be connected alternately on adjacent poles.

Mounting through the backplate (shown with optional connection bars oriented for rear access)

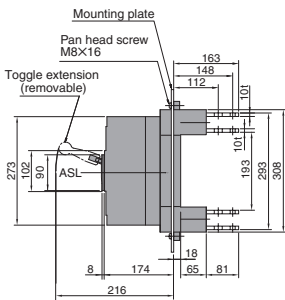

(rear view)

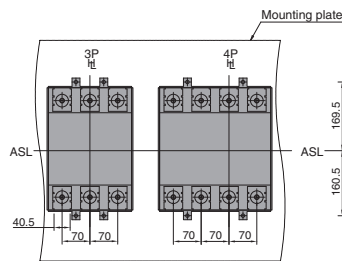

Drilling plan (front view)

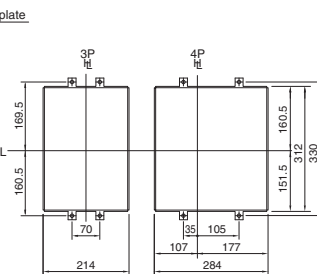

Detail of connecting part Oriented for rear access

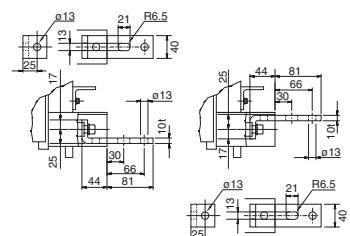

Terminal bars should be connected alternately on adjacent poles.

Mounting on the backplate (optional connection bars must be oriented for front access)

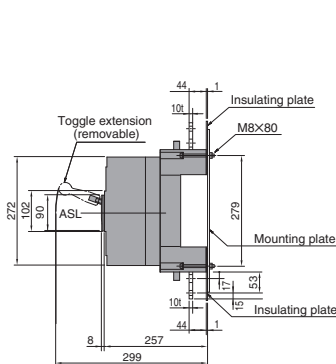

(rear view)

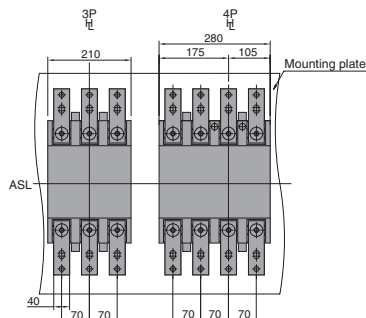

Drilling plan (front view)

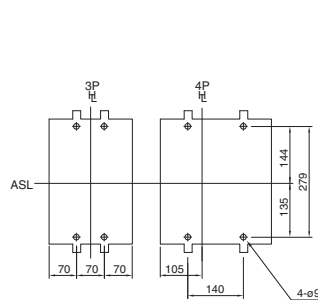

Detail of connecting part Oriented for front access

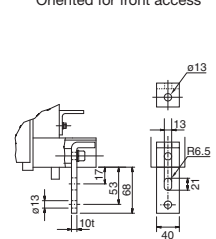

S1000-SE, S1000-NE, S1000-NN

ASL: Arrangement Standard Line
 HL: Handle Frame Centre Line

Front connected

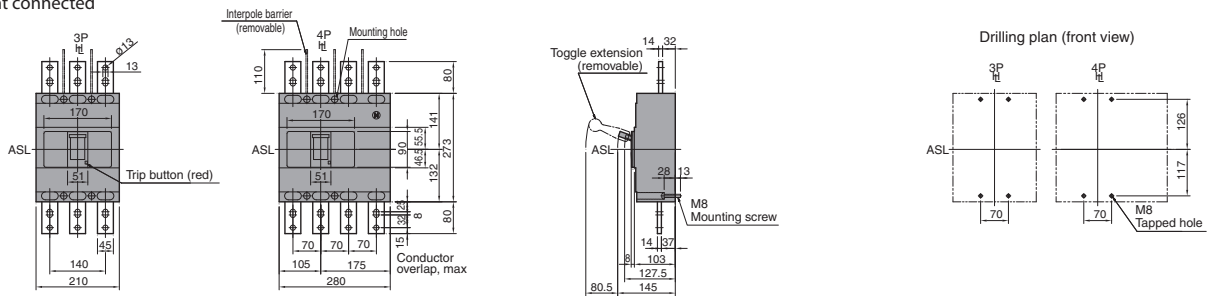

Rear connected

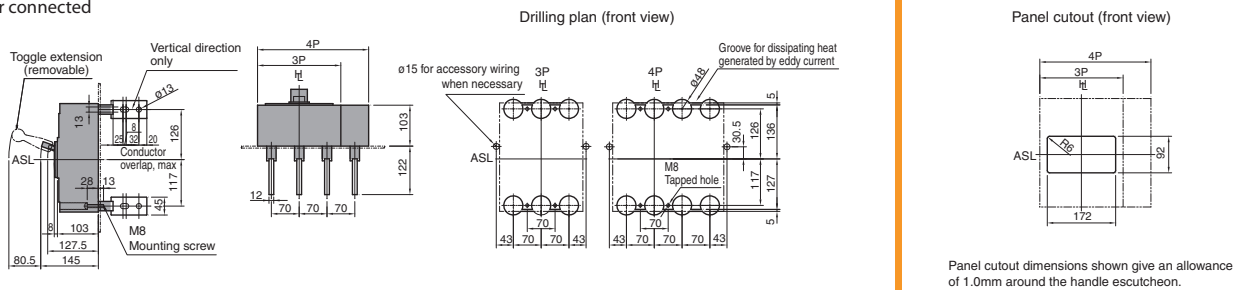

Front connected with Motor Operator

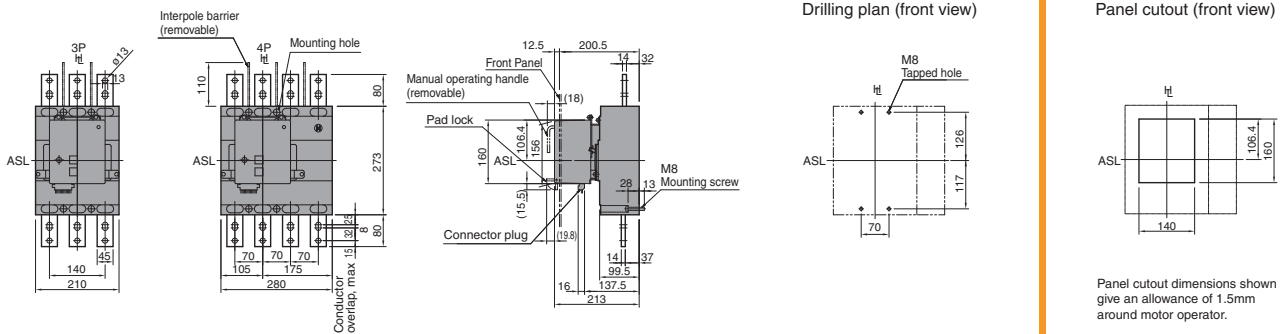

Rear connected with Motor Operator

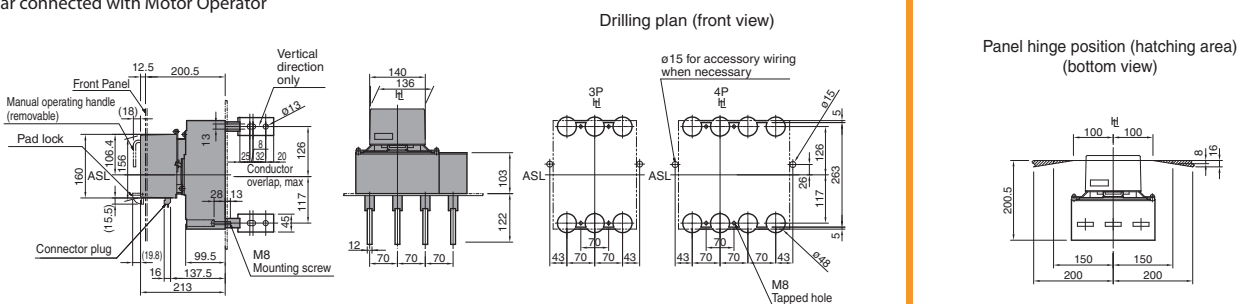

Note: Studs are factory installed in horizontal direction both on the line and load sides.

DIMENSIONS

S1250-SE, S1250-NE, S1250-GE, S1250-NN

ASL: Arrangement Standard Line

HL: Handle Frame Centre Line

Front connected

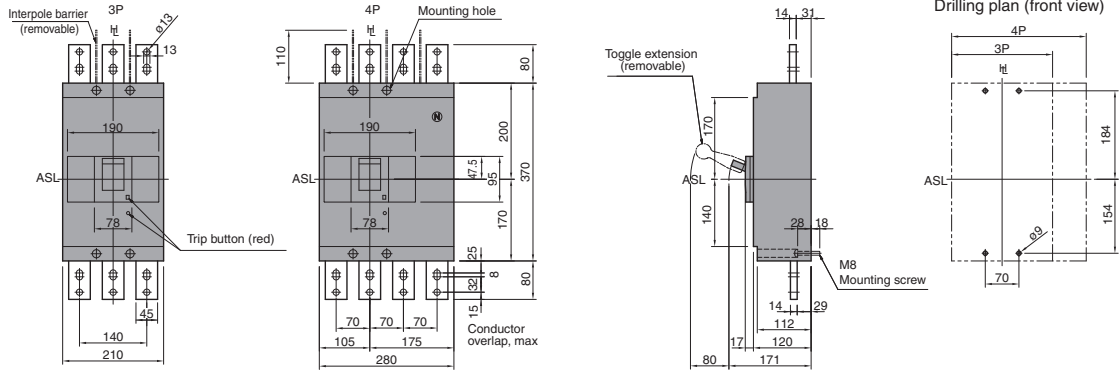

Rear connected

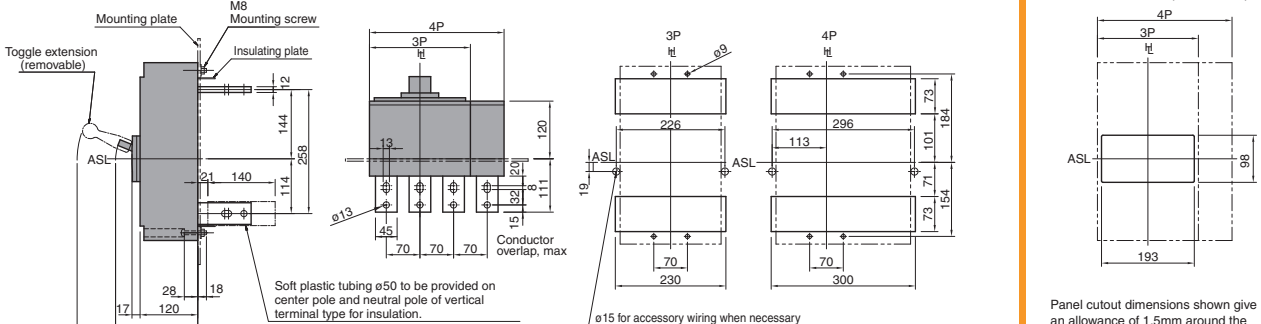

Front connected with Motor Operator

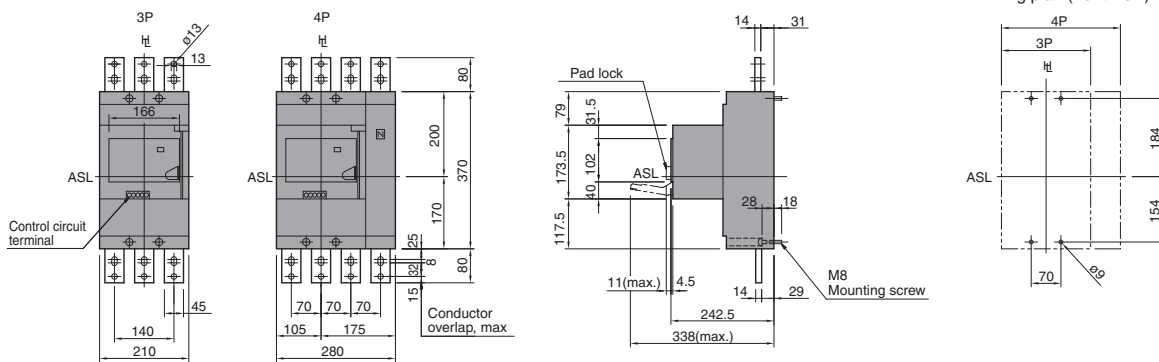

Rear connected with Motor Operator

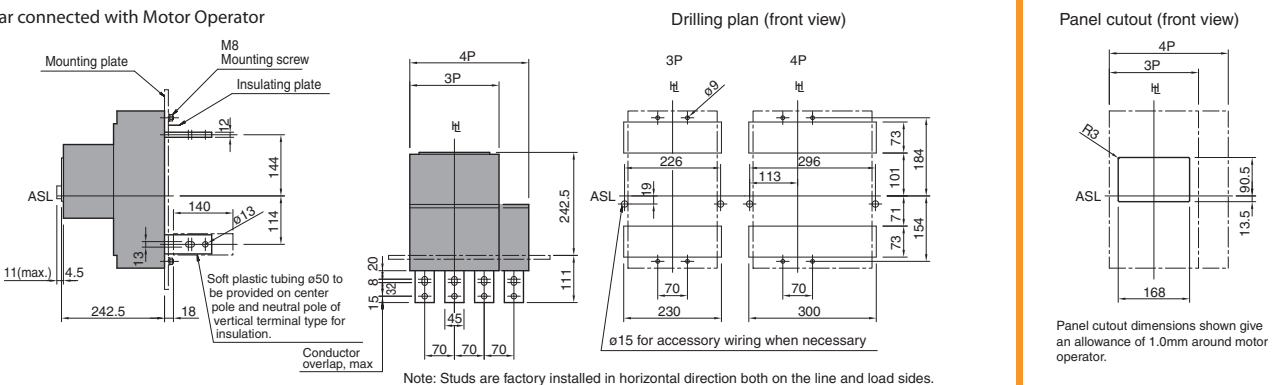

S1250-SE, S1250-NE, S1250-GE, S1250-NN. Plug-in Versions

ASL: Arrangement Standard Line

HL: Handle Frame Centre Line

Plug-in

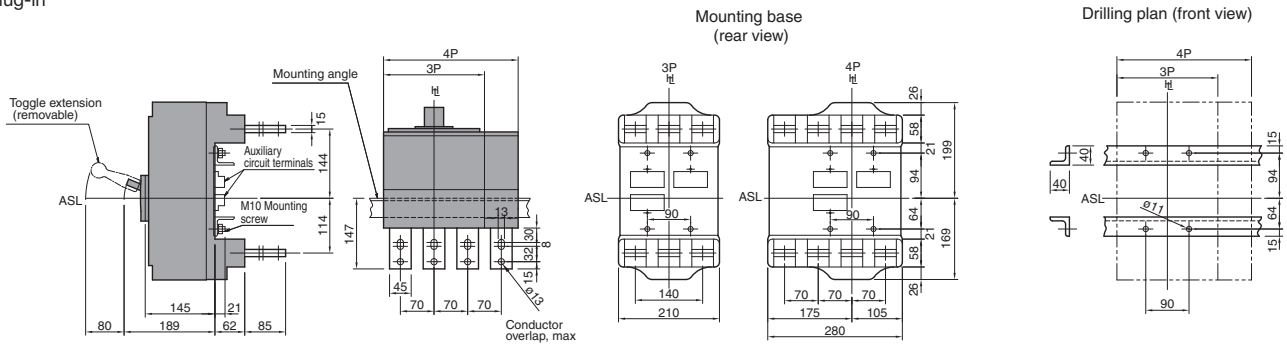

Plug-in with Motor Operator

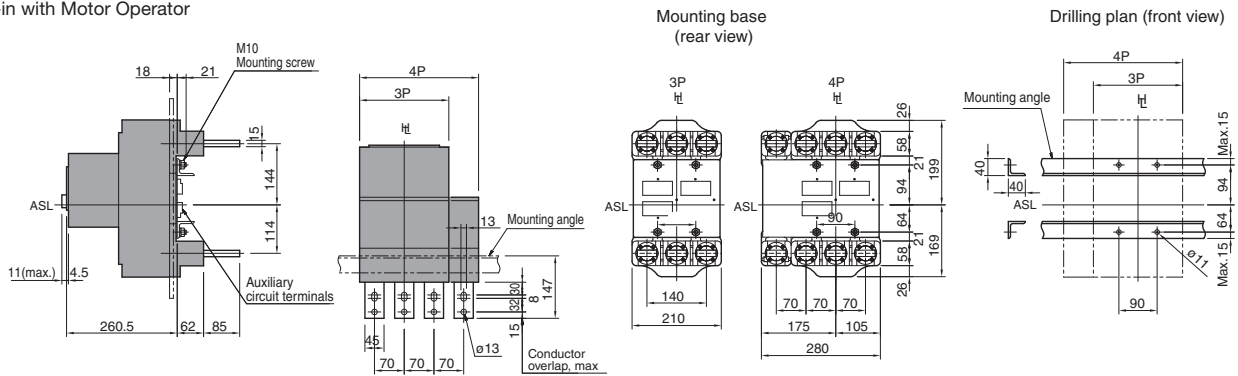

Panel cutout (front view)

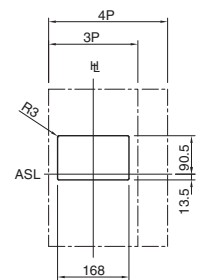

Panel cutout dimensions shown give an allowance of 1.0mm around motor operator.

DIMENSIONS

S1600-SE, S1600-NE, S1600-NN

ASL: Arrangement Standard Line

Ht: Handle Frame Centre Line

Front connected

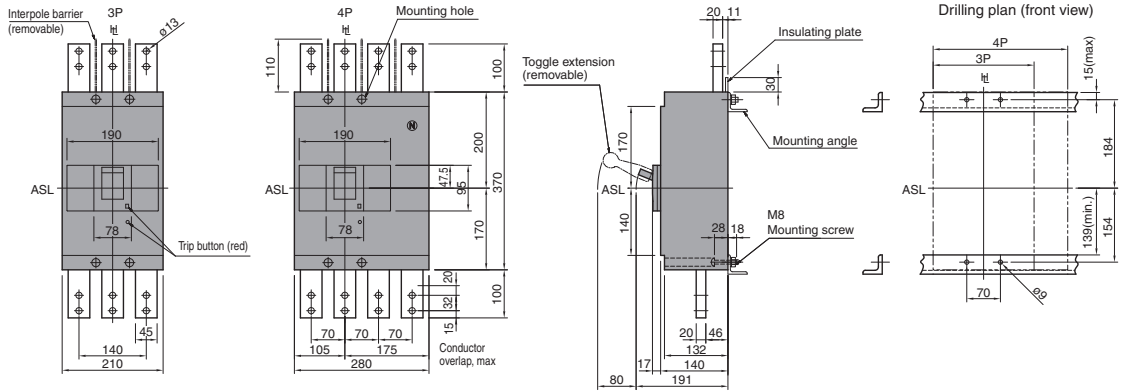

Rear connected

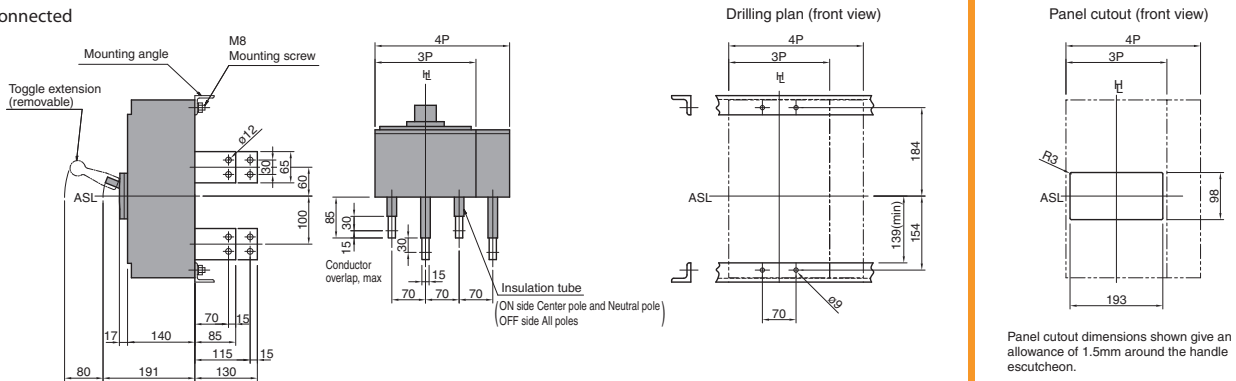

Panel cutout dimensions shown give an allowance of 1.5mm around the handle escutcheon.

Front connected with Motor Operator

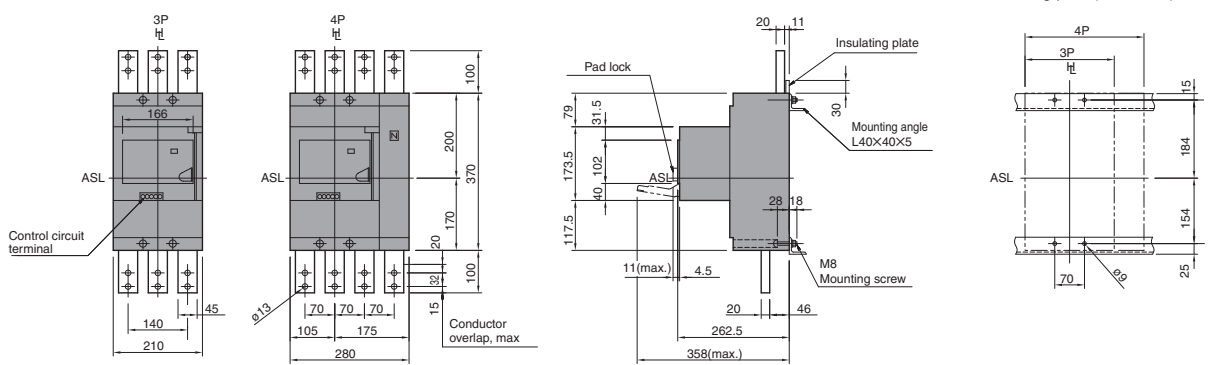

Rear connected with Motor Operator

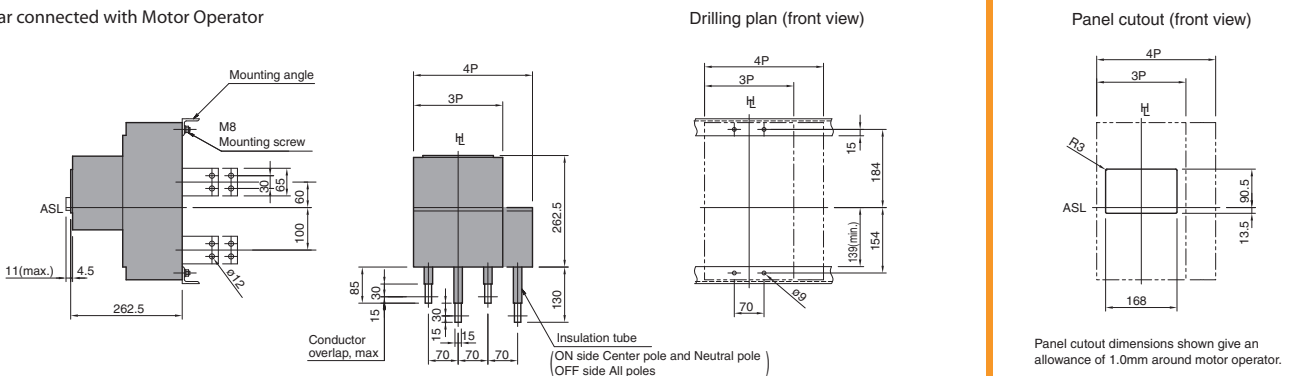

Panel cutout dimensions shown give an allowance of 1.0mm around motor operator.

S1600-SE, S1600-NE, S1600-NN. Draw-out Versions

ASL: Arrangement Standard Line

ht : Handle Frame Centre Line

Draw-out

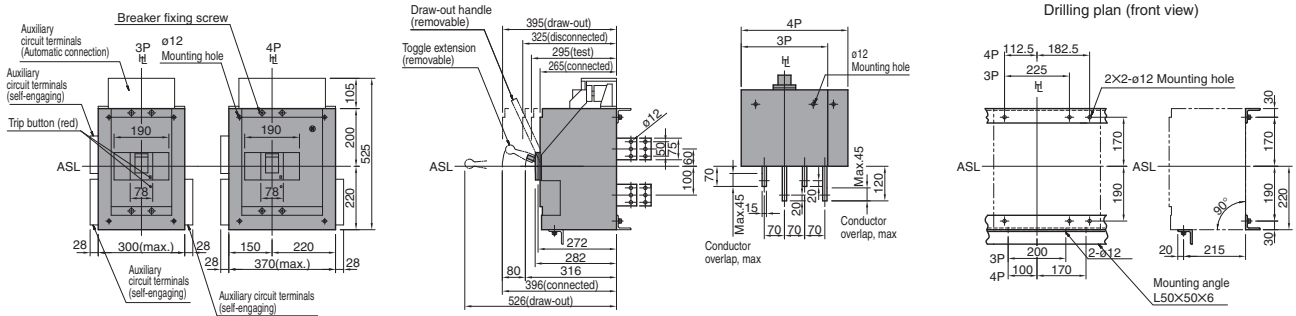

Draw-out with Motor Operator

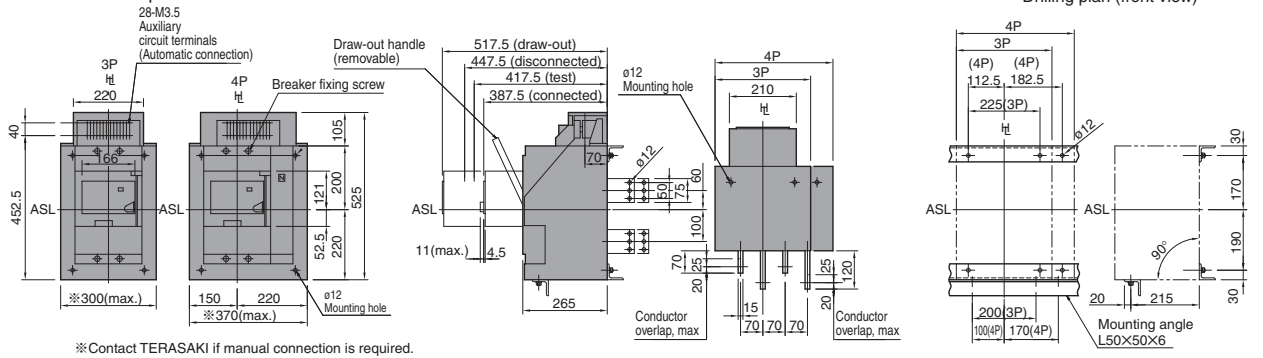

Panel cutout (front view)

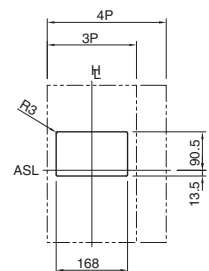

Panel cutout dimensions shown give an allowance of 1.0mm around motor operator.

DIMENSIONS

Breaker Mounted Handle

Applicable MCCB

E125, S125

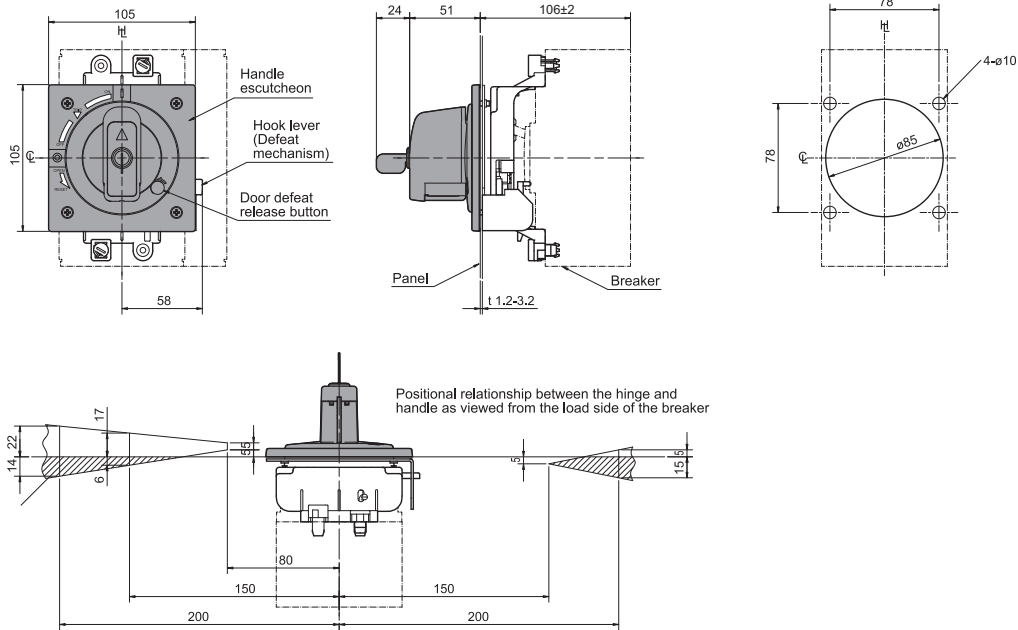

Applicable MCCB

A

S160-NJ, E250-NJ,
S250-NJ, S250-GJ,
S250-NN

106±2

H125, L125, H160, L160,
S250-NE, S250-GE,
S250-PE, H250, L250

141±2

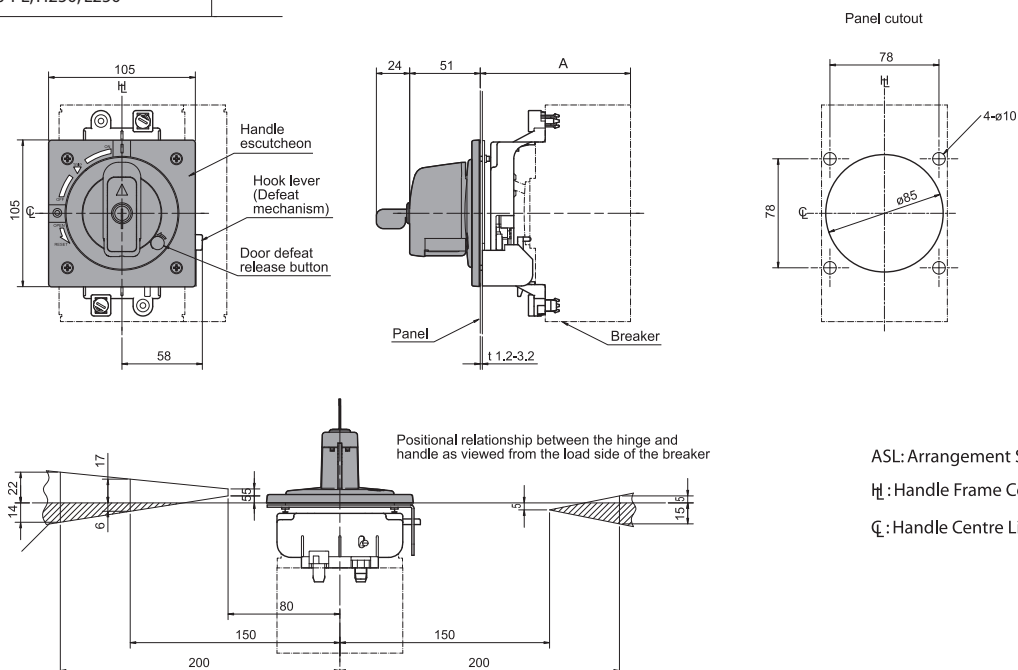

ASL: Arrangement Standard Line

ht: Handle Frame Centre Line

CL: Handle Centre Line

Breaker Mounted Handle

Applicable MCCB	A	B
E400 S400 E630 S630	150±2	97
H400 L400	187±2	134

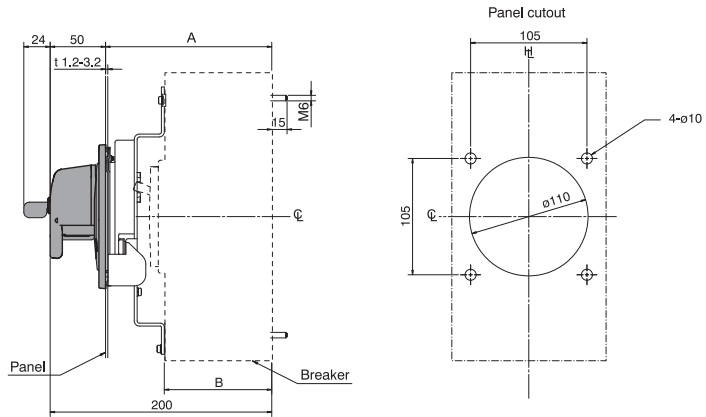
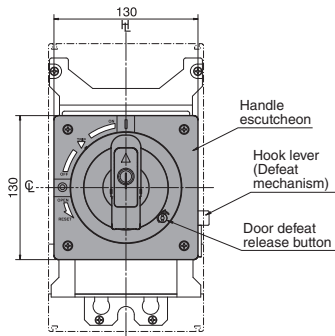

ASL: Arrangement Standard Line
 HL: Handle Frame Centre Line
 CL: Handle Centre Line

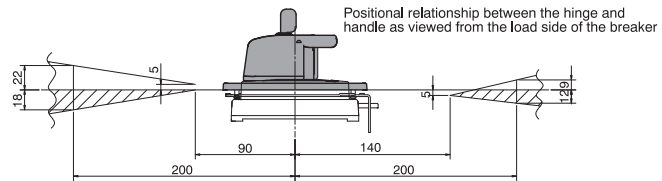

Applicable MCCB	A
S800 S1000	150±2
H800 L800	187±2

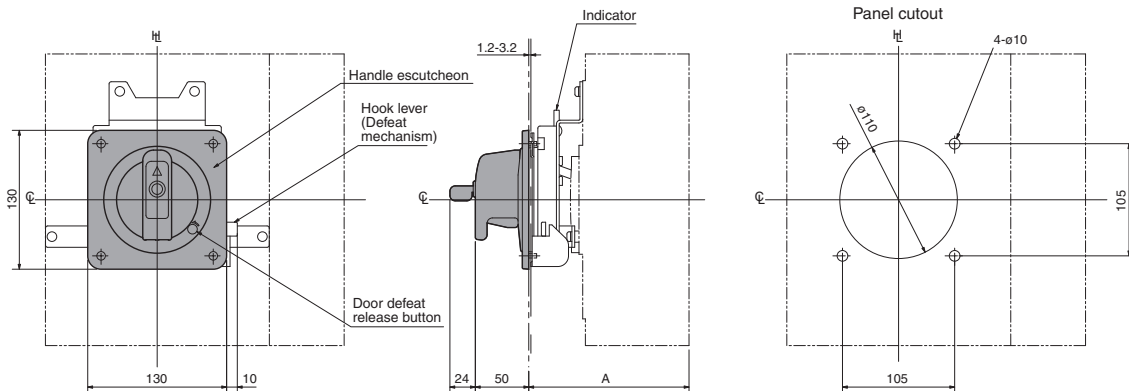

ASL: Arrangement Standard Line
 HL: Handle Frame Centre Line
 CL: Handle Centre Line

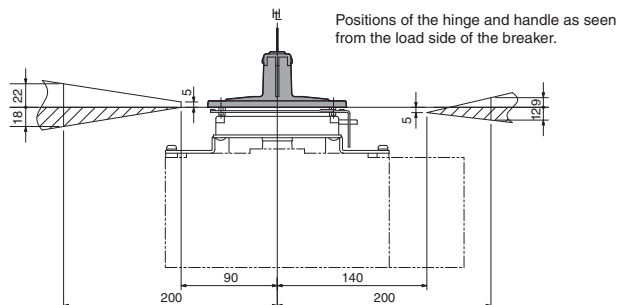

DIMENSIONS

Door Mounted Handle standard type

Applicable MCCB	A*1	B	C
E125 S125	453 max.	358	144

*1: Max. means the maximum length for A without cutting the shaft.
+ The shaft can be cut to the required length.

A: Distance from the panel surface to the breaker mounting surface
B: Length of the square shaft used

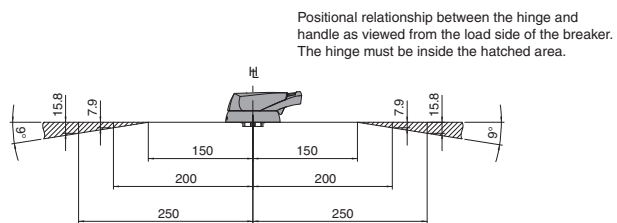
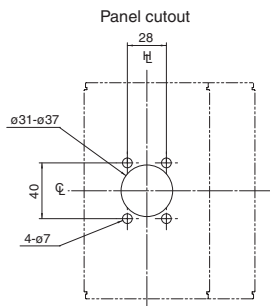
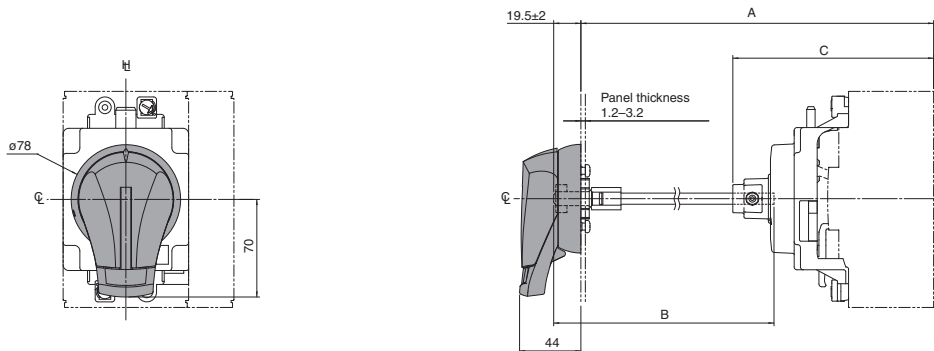

ASL: Arrangement Standard Line
H: Handle Frame Centre Line
C: Handle Centre Line

Padlock dimensions (mm)



Door Mounted Handle standard type

Applicable MCCB	A*1	B	C
S160-NJ, E250-NJ, S250-NJ, S250-GJ S250-NN	453 max.	358	144
H125, L125, H160, L160, S250-NE, S250-GE, S250-PE, H250, L250	488 max.	358	179

*1: Max. means the maximum length for A without cutting the shaft.
+ The shaft can be cut to the required length.

A: Distance from the panel surface to the breaker mounting surface
B: Length of the square shaft used

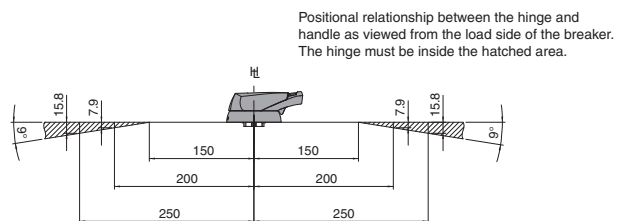
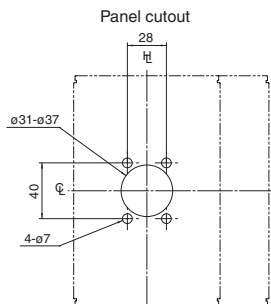
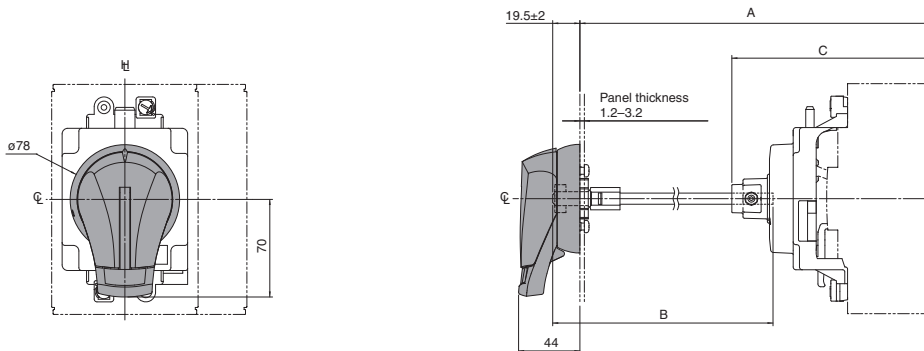

ASL: Arrangement Standard Line
Ht: Handle Frame Centre Line
C: Handle Centre Line

Padlock dimensions (mm)

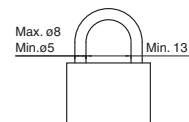

DIMENSIONS

Door Mounted Handle standard type

Applicable MCCB	A*1	B	C
E400 E630	220 min.	86	188.5
S400 S630	456 max.	322	188.5
H400	257 min.	86	225.5
L400	493 max.	322	225.5

*1: Min. means the minimum length for A by cutting the shaft.
 Max. means the maximum length for A without cutting the shaft.
 + The shaft can be cut to the required length.

A: Distance from the panel surface to the breaker mounting surface
 B: Length of the square shaft used

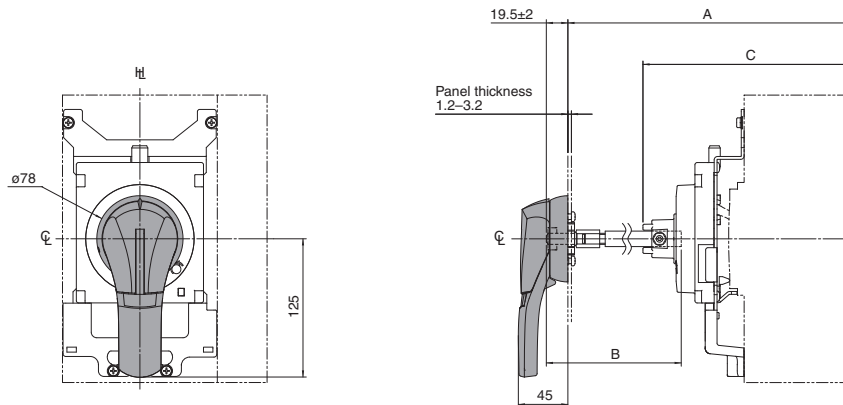

Panel cutout

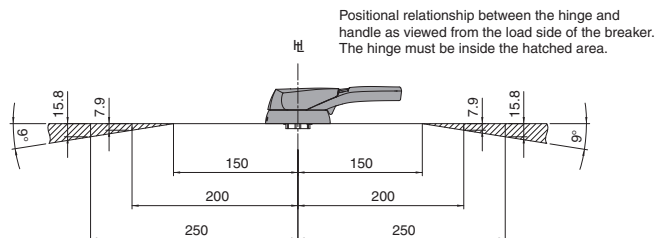
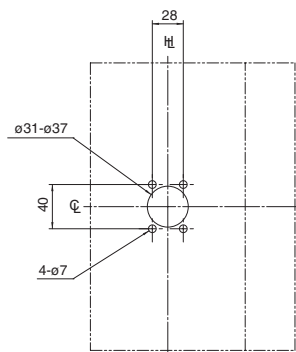

Positional relationship between the hinge and handle as viewed from the load side of the breaker. The hinge must be inside the hatched area.

ASL: Arrangement Standard Line

Padlock dimensions (mm)

H_L: Handle Frame Centre Line

CL: Handle Centre Line

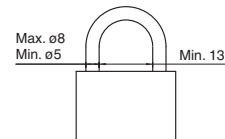

Door Mounted Handle standard type

Applicable MCCB	A*1	B	C
S800, S1000	220 min.	86	188.5
	456 max.	322	188.5
H800, L800	257 min.	86	225.5
	493 max.	322	225.5

*1: Min. means the minimum length for A by cutting the shaft.
 Max. means the maximum length for A without cutting the shaft.
 + The shaft can be cut to the required length.

A: Distance from the panel surface to the breaker mounting surface
 B: Length of the square shaft used

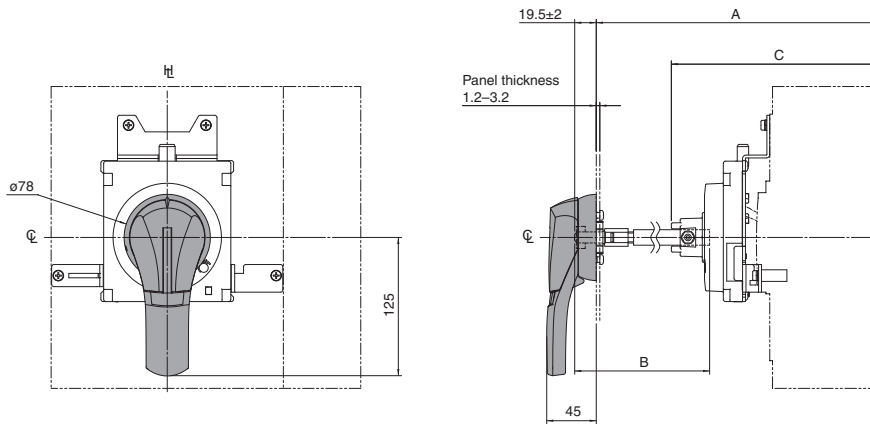

Panel cutout

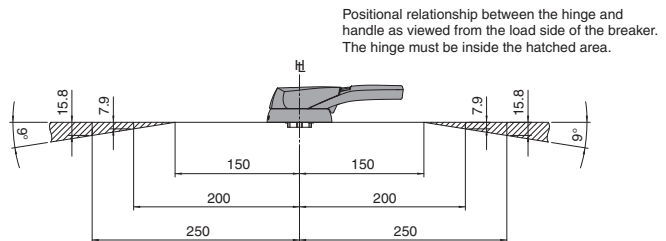
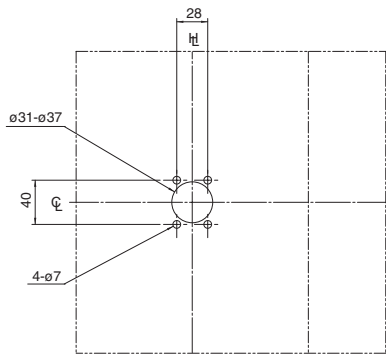

ASL: Arrangement Standard Line
 H: Handle Frame Centre Line
 C: Handle Centre Line

Padlock dimensions (mm)

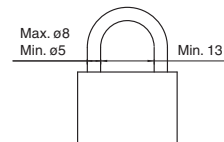

DIMENSIONS

Door Mounted Handle standard type

Applicable MCCB	A*1	B	C
S1250	276.5min.	86	245
	512.5max.	322	245
S1600	296.5min.	86	265
	532.5max.	322	265

*1: Min. means the minimum length for A by cutting the shaft.
 Max. means the maximum length for A without cutting the shaft.
 + The shaft can be cut to the required length.

A: Distance from the panel surface to the breaker mounting surface
 B: Length of the square shaft used

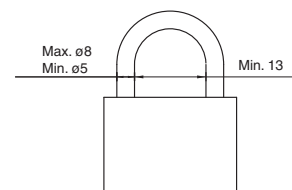
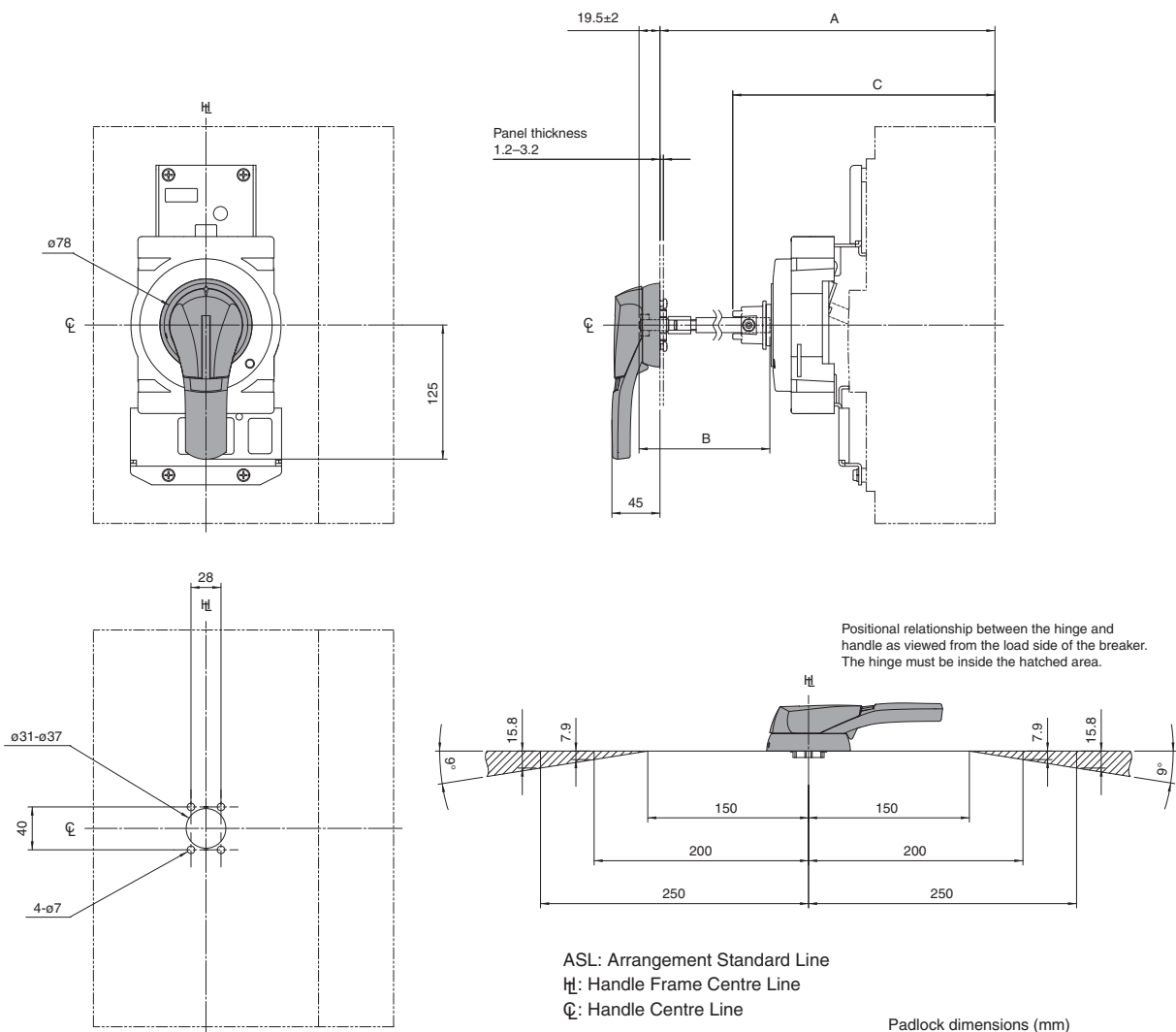

Door Mounted Handle ordinal type

Applicable MCCB	A*1	B	C	Shaft support
E125 S125	543 max.	370	421	With +

*1: Max. means the maximum length for A without cutting the shaft.

+ The shaft can be cut to the required length. If it is necessary to cut the shaft so short that it does not protrude beyond the shaft support, the shaft support may be removed.

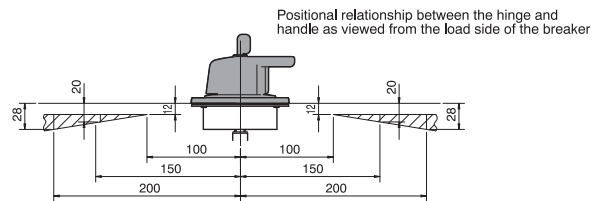
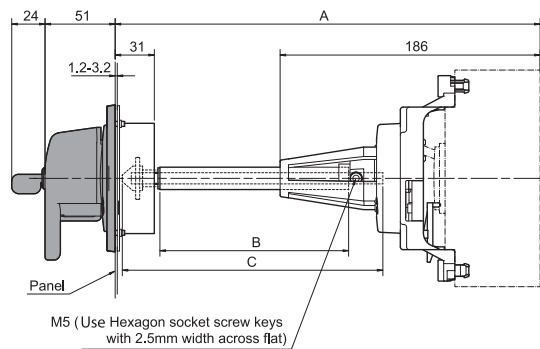
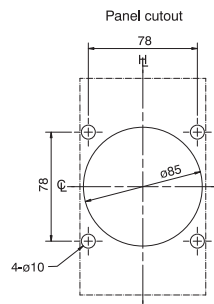
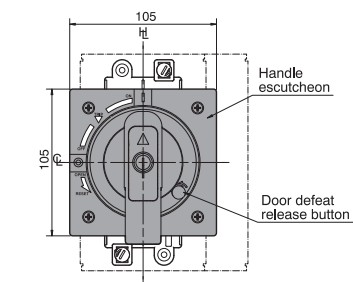

ASL: Arrangement Standard Line

h_l : Handle Frame Centre Line

Q : Handle Centre Line

Padlock dimensions (mm)



DIMENSIONS

Door Mounted Handle ordinal type

Applicable MCCB	A*1	B	C	D	Shaft support
S160-NJ, E250-NJ, S250-NJ, S250-GJ S250-NN	543 max.	370	421	186	With +
H125, L125, H160, L160, S250-NE, S250-GE, S250-PE, H250, L250	578 max.	370	421	221	With +

*1: Max. means the maximum length for A without cutting the shaft.

+ The shaft can be cut to the required length. If it is necessary to cut the shaft so short that it does not protrude beyond the shaft support, the shaft support may be removed.

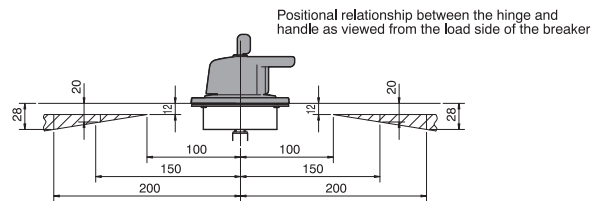
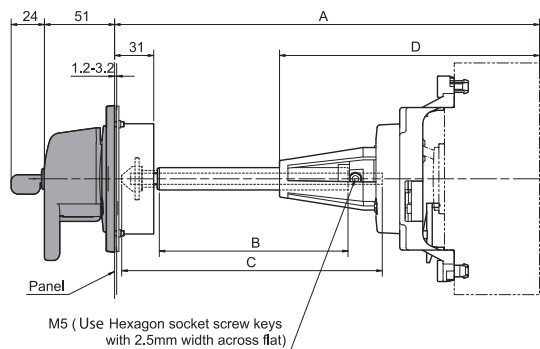
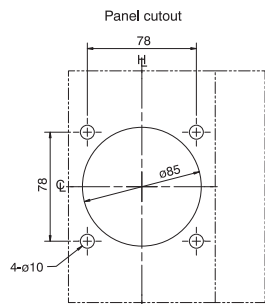
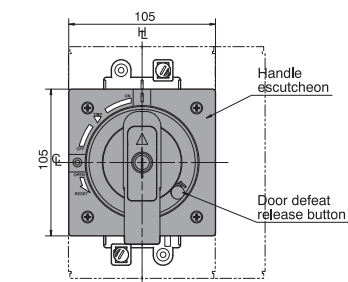

ASL: Arrangement Standard Line

HL: Handle Frame Centre Line

CL: Handle Centre Line

Padlock dimensions (mm)



Door Mounted Handle ordinal type

Applicable MCCB	A*1	B	C	D	Shaft support
E400 E630	270 min.	12	107.5	—	Without
S400 S630	610 max.	280	447.5	261	With +
H400	307 min.	12	107.5	—	Without
L400	647 max.	280	447.5	298	With +

*1: Min. means the minimum length for A by cutting the shaft.

Max. means the maximum length for A without cutting the shaft.

+ The shaft can be cut to the required length. If it is necessary to cut the shaft so short that it does not protrude beyond the shaft support, the shaft support may be removed.

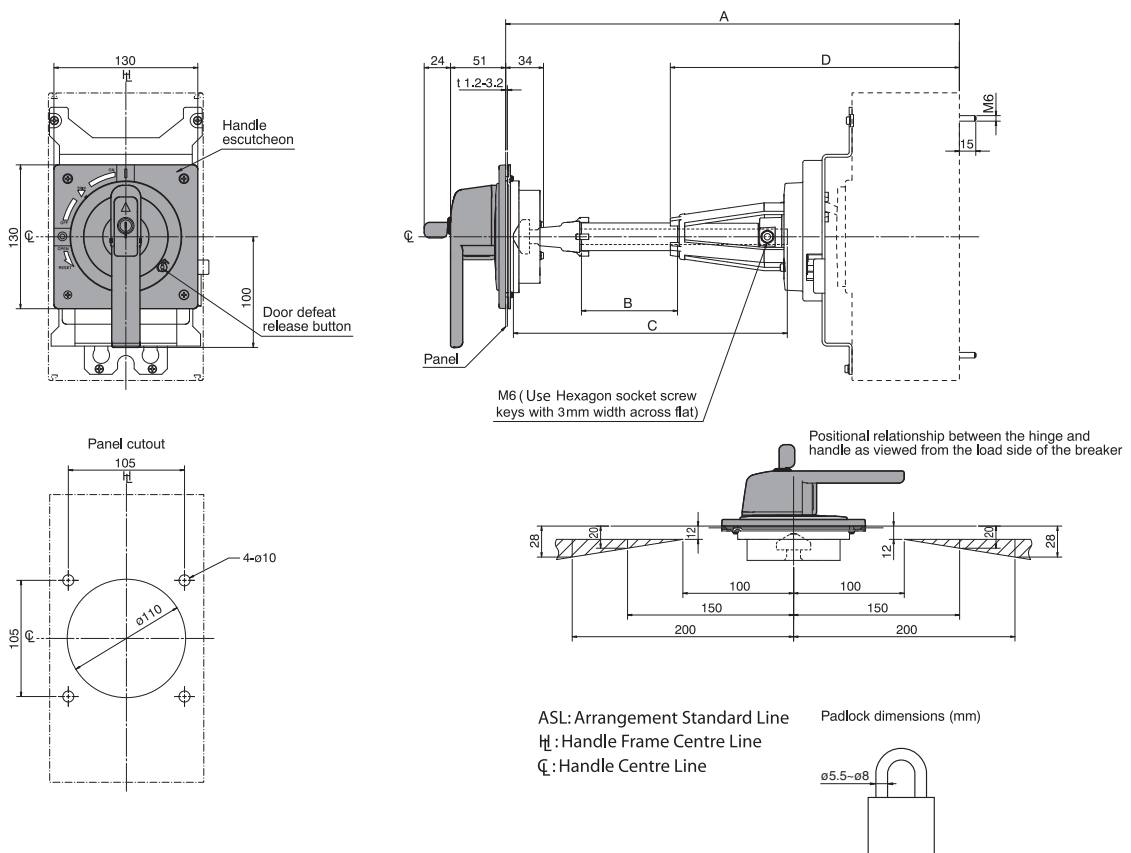

DIMENSIONS

Door Mounted Handle ordinal type

Applicable MCCB	A*1	B	C	D	Shaft support
S800, S1000	270 min.	12	107.5	—	Without
	610 max.	280	447.5	261	With +
H800, L800	307 min.	12	107.5	—	Without
	647 max.	280	447.5	298	With +

*1: Min. means the minimum length for A by cutting the shaft.

Max. means the maximum length for A without cutting the shaft.

+ The shaft can be cut to the required length. If it is necessary to cut the shaft so short that it does not protrude beyond the shaft support, the shaft support may be removed.

A: Distance from the panel surface to the breaker mounting surface

B: Length of the tube used to cover the square shaft

C: Length of the square shaft used

D: Distance from the tip of the shaft support to the breaker mounting surface

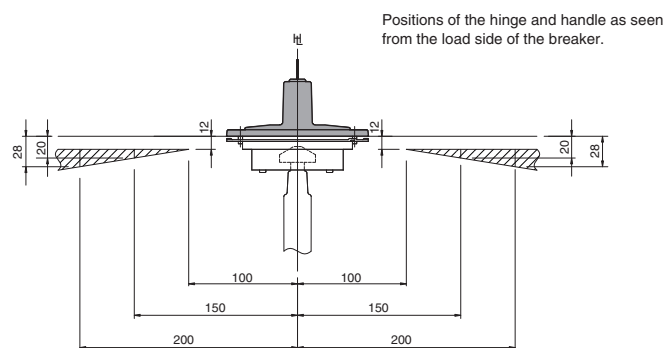
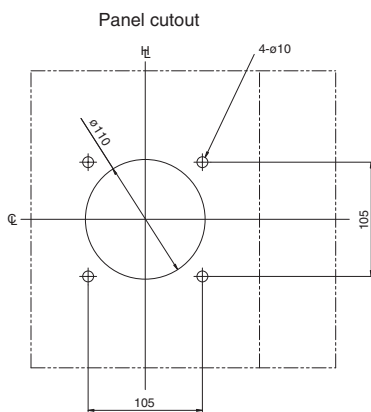
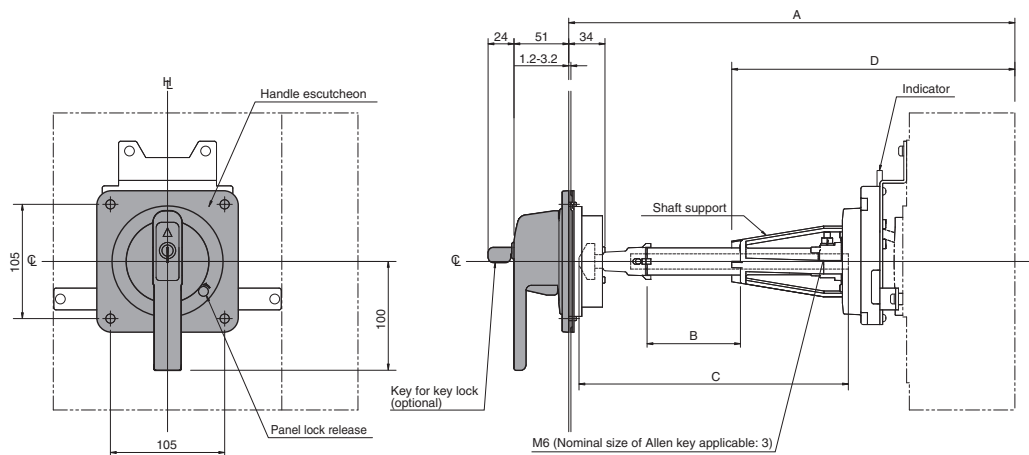

Door Mounted Handle ordinal type

Applicable MCCB	A *1	B	C	D	Shaft support
S1250	367min.	52	147.5	317	Without
	667max.	280	447.5	317	With +
S1600	387min.	52	147.5	337	Without
	687max.	280	447.5	337	With +

*1: Min. means the minimum length for A by cutting the shaft.

Max. means the maximum length for A without cutting the shaft.

+ The shaft can be cut to the required length. If it is necessary to cut the shaft so short that it does not protrude beyond the shaft support, the shaft support may be removed.

A: Distance from the panel surface to the breaker mounting surface
C: Length of the square shaft used

B: Length of the tube used to cover the square shaft
D: Distance from the tip of the shaft support to the breaker mounting surface

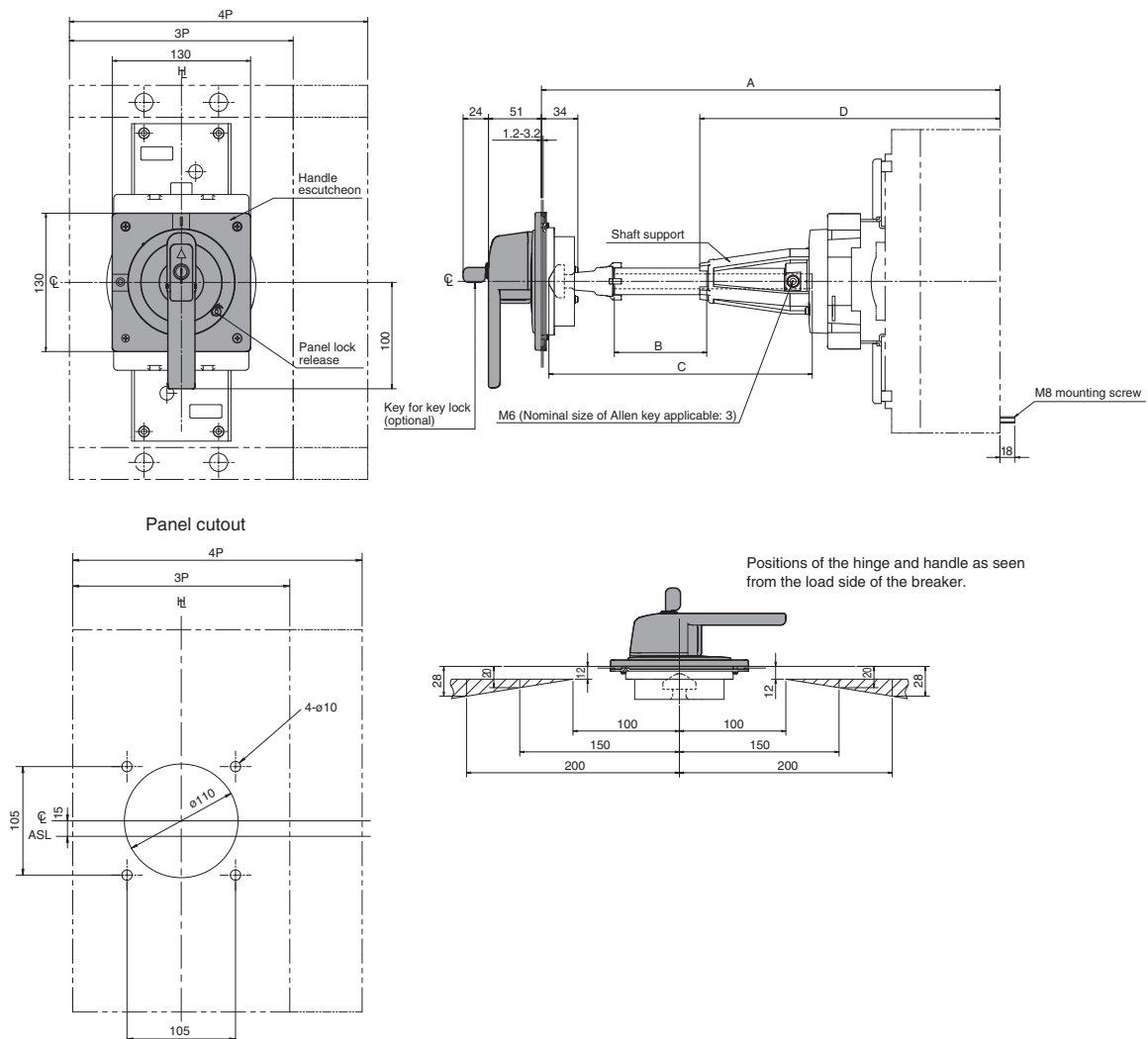

DIMENSIONS

Terminal Covers

Terminal covers for Front connected MCCB's (CF)

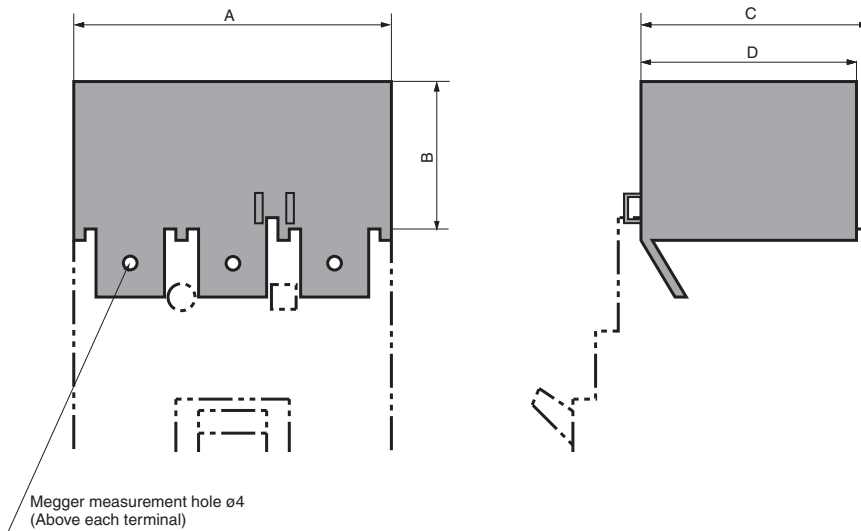

Plug-in mounted version

This version can be mounted simply by being plugged in the breaker body.

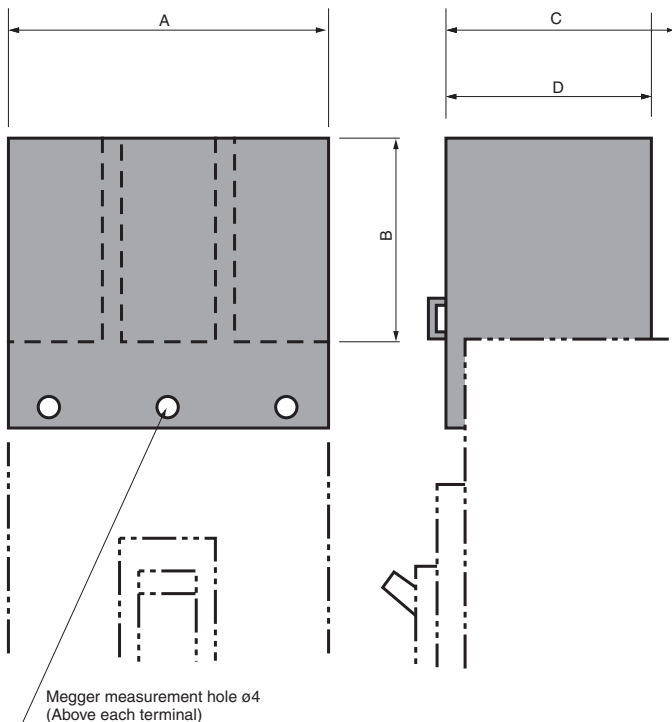

Screw-mounted version

The terminal covers for 630 to 800AF are mounted to the breakers using tapping screws. The terminal cover for 1250AF is mounted to insert nuts of the breaker cover using screws. The insert nuts do not come standard with the breaker. Please be sure to state "with terminal cover (CF)" when ordering the breaker.

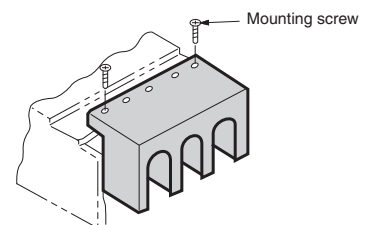

Terminal Covers

Terminal covers for Cable clamp terminal type MCCB's (CS)

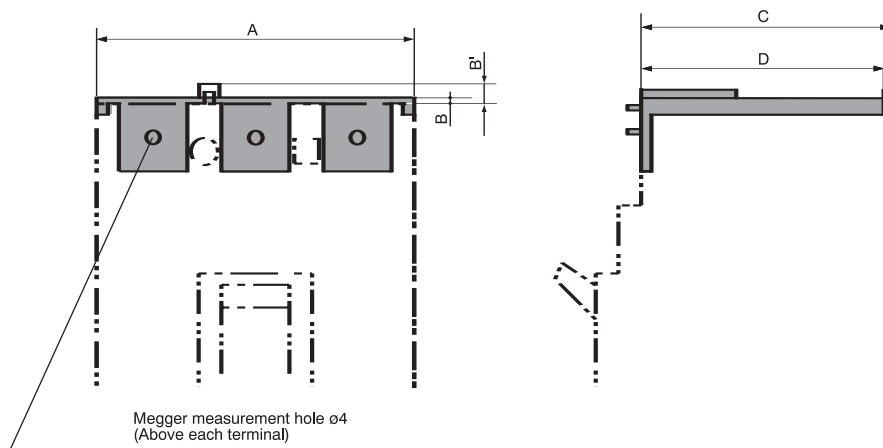

MCCB type	Connection	A			B			B'	C			D			Mounting version	
		1P	3P	4P	1P	3P	4P	3P, 4P	1P	3P	4P	1P	3P	4P	Plug-in mounted	Screw-mounted
E125, S125	Front conn.	30	90	120	40	40	40	o	48	48	48	46	46	46	○	—
	Cable clamp	30	90	120	2.5	2.5	2.5	6	62.5	61	61	60	59.5	59.5	○	—
S160.-NJ, S160NN E250-NJ, S250-NJ, S250-GJ, S250-NN	Front conn. (1)	35	105	140	55	55	55	o	54	54	54	52	52	52	○	—
	Cable clamp	35	105	140	2.5	2.5	2.5	6	63	61	61	49.5	59.5	59.5	○	—
H125, L125, H160, L160, S250-NE, S250-GE, S250-PE H250, L250	Front conn. (1)	o	105	140	o	55	55	o	o	89	89	o	87	87	○	—
	Cable clamp	o	105	140	o	2.5	2.5	4.5	o	96	96	o	59.5	59.5	○	—
E400, S400 E630, S630	Front conn. Wide type	o	180	240	o	110	114	o	o	97	98	o	94.5	98	○	—
	Front conn. Straight type	o	140	185	o	85	85	o	o	97	97	o	94.5	94.5	○	—
	Cable clamp	o	140	185	o	3	3	4.5	o	97	97	o	93	93	○	—
H400, L400	Front conn. Wide type	o	180	240	o	110	114	o	o	134	135	o	94.5	98	○	—
	Front conn. Straight type	o	140	185	o	85	85	o	o	134	134	o	94.5	94.5	○	—
	Cable clamp	—	140	185	o	3	3	4.5	o	134	134	o	93	93	○	—
S800, S1000	Front conn. (3)	—	215	285	—	130	130	—	—	99.5 (102)	99.5 (102)	—	99 (101.5)	99 (101.5)	—	○
H800, L800	Front conn. (2) (3)	—	215	285	—	130	130	—	—	99.5 (139)	99.5 (139)	—	99 (101.5)	99 (101.5)	—	○
S1250	Front conn. (3)	—	215	285	—	130	130	—	—	115	115	—	99 (102.5)	99 (102.5)	—	○

Notes:

- (1) Not applicable when extension bars (FB) are fitted.
- (2) There will be an approx. 40 mm gap between the bottom of the terminal cover and the breaker mounting surface.
- (3) Values in parentheses indicate the distance to the head of terminal cover mounting screws.

DIMENSIONS

Terminal Covers

Terminal covers for Rear connected and Plug-in MCCB's (CR)

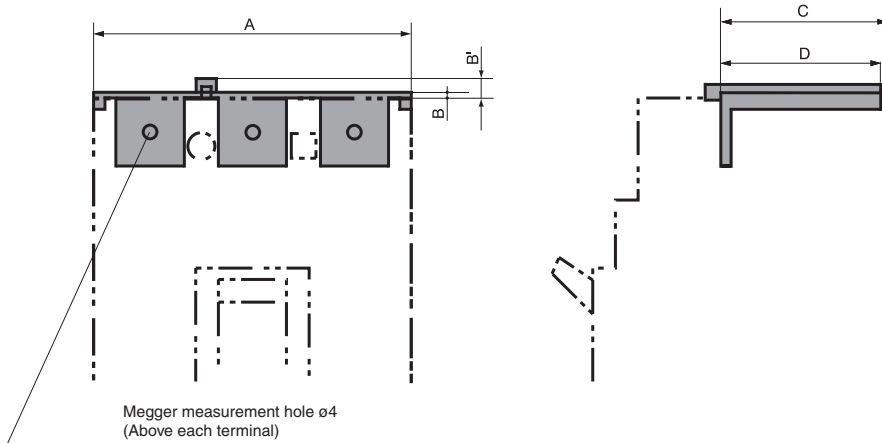

Plug-in mounted version

This version can be mounted simply by being plugged in the breaker body.

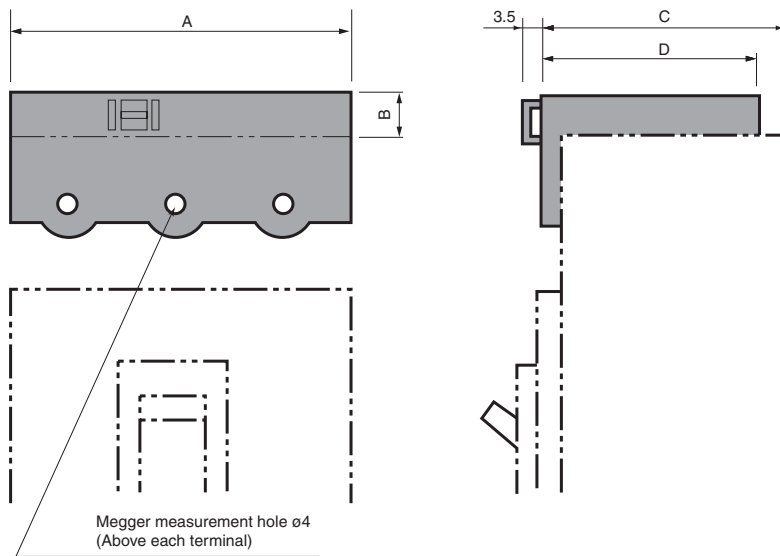

Screw-mounted version

The terminal covers for 630 to 800AF are mounted to the breakers using tapping screws.

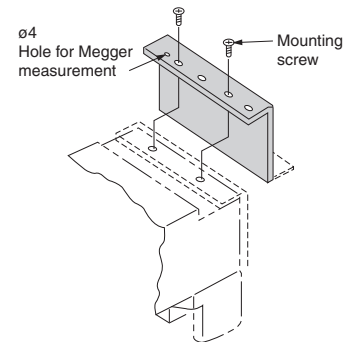

MCCB type	A		B		B'	C		D		Mounting version	
	3 poles	4 poles	3 poles	4 poles		3 poles	4 poles	3 poles	4 poles	Plug-in mounted	Screw-mounted
E125, S125	90	120	2	2	6	41.5	41.5	40.5	40.5	○	—
S160, E250, S250-NJ, S250-GJ, S250-NN	105	140	2	2	6	42.5	42.5	39.5	39.5	○	—
H125, L125, H160, L160, S250-NE, S250-GE, S250-PE, H250, L250	105	140	2	2	6	77.5	77.5	39.5	39.5	○	—
E400, S400, E630, S630	140	185	3	3	5	97	97	93	93	○	—
H400, L400, (1)	140	185	3	3	5	134	134	93	93	○	—
S800, S1000 (2)	206	280	15	18	—	101 (103.5)	99 (101.5)	100.5 (103)	98 (100.5)	—	○
H800, L800 (2)	210	280	15	15	—	136 (138.5)	136 (138.5)	135 (137.5)	135 (137.5)	—	○

Notes:

(1): There will be an approx. 40 mm gap between the bottom of the terminal cover and the breaker mounting surface.

(2): Values in parentheses indicate the distance to the head of terminal cover mounting screws.

Interpole Barriers

Terminal Interpole Barriers (BA)

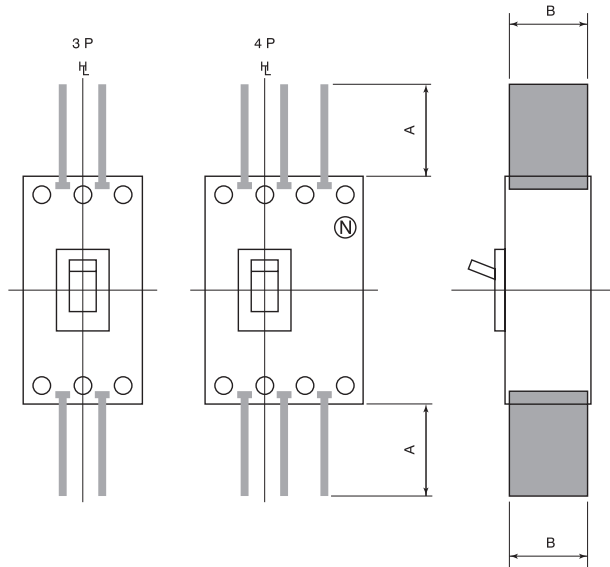

MCCB type	A	B
E125, S125	47	53
S160, E250, S250-NJ, S250-GJ, S250-NN	100	53
H125, L125, H160, L160, S250-NE, S250-GE, S250-PE, H250, L250	100	88
E400, S400, E630, S630	110	95
H400, L400	110	95
S800, H800, L800, S1000	110	95

ASL: Arrangement Standard Line

HL: Handle Frame Centre Line

CL: Handle Centre Line

DIMENSIONS

Terminal Blocks for Front-Connected and Rear-Connected MCCBs

11 terminals

Left terminal designations

Example

AXc1	AXc1
AXb1	AXb1
AXa1	AXa1
AXc2	AXc2
AXb2	AXb2
AXa2	AXa2
ALc1	ALc1
ALb1	ALb1
ALa1	ALa1
C1	D1
C2	D2

With SHT With UVT

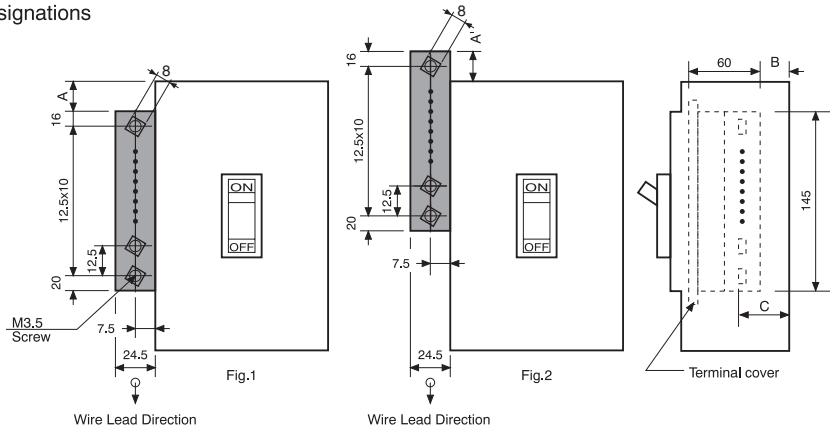

MCCB type	A	A'	B	C	Fig
E125, S125	—	3	0.5	40	2
S160, E250, S250-NJ, S250-GJ, S250-NN	2	—	0.5	40	1
H125, L125, H160, L160, S250-NE, S250-GE, S250-PE, H250, L250	2	—	35.5	75	1

Comments:

- The tightening torque for the M3.5 terminal screws is 0.9 to 1.2 N·m.
- Connection wire size is 2.5mm² (max).

11 terminals

Left terminal designations

Wire Lead direction

Right terminal designations

AXc1
AXb1
AXa1
AXc2
AXb2
AXa2
ALc1
ALb1
ALa1
AXc3
AXb3

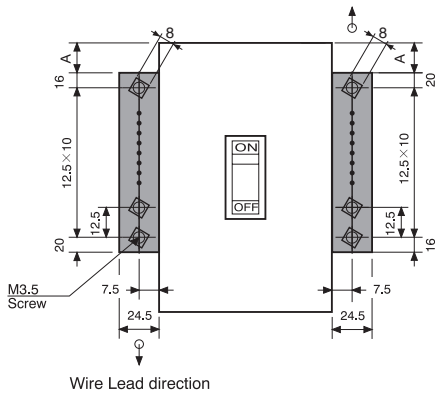

PALc	PALc
PALa	PALa
k	k
/	/
C1	D1
C2	D2

With SHT With UVT

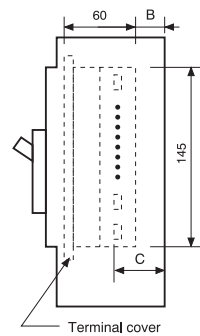

MCCB type	A	B	C
E400, S400, E630, S630	39.5	30.5	70
H400, L400	39.5	67.5	107
S800, S1000	31	30.5	70
H800, L800	31	67.5	107

Comments:

- The tightening torque for the M3.5 terminal screws is 0.9 to 1.2 N·m.
- Connection wire size is 2.5mm² (max).
- When you specify Ground Fault Trip on electronic MCCBs with 3 poles the terminal block is automatically fitted to connect with the external neutral CT for 3 phases 4 wires system.

Terminal Blocks for Front-Connected and Rear-Connected MCCBs

6 terminals

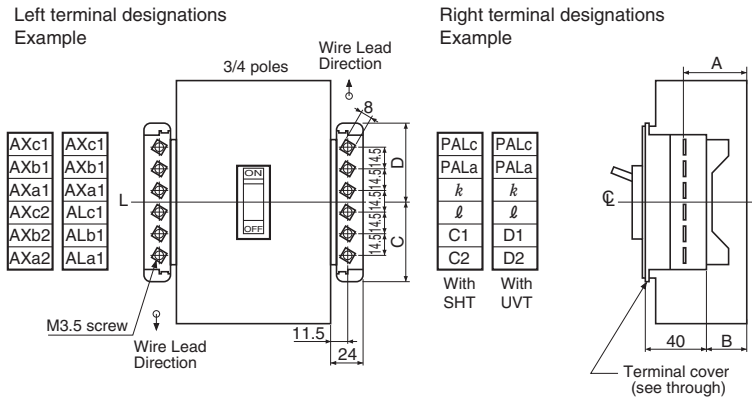

MCCB Type	A	B	C	D
E125, S125	42.5	27	53	53
S160, E250, S250-NJ, S250-GJ, S250-NN	42.5	27	53	53
H125, L125, H160, L160, S250-NE, S250-GE, S250-PE, H250, L250	77.5	62	53	53
E400, S400, E630, S630	72.5	57	43	63
H400, L400	109.5	94	43	63
S800, S1000	72.5	57	23.5	82.5
H800, L800	109.5	94	23.5	82.5

Comments:
 1. The tightening torque for the M3.5 terminal screws is 0.9 to 1.2 N·m.
 2. Connection wire size is 1.25mm² (max).

6 terminals

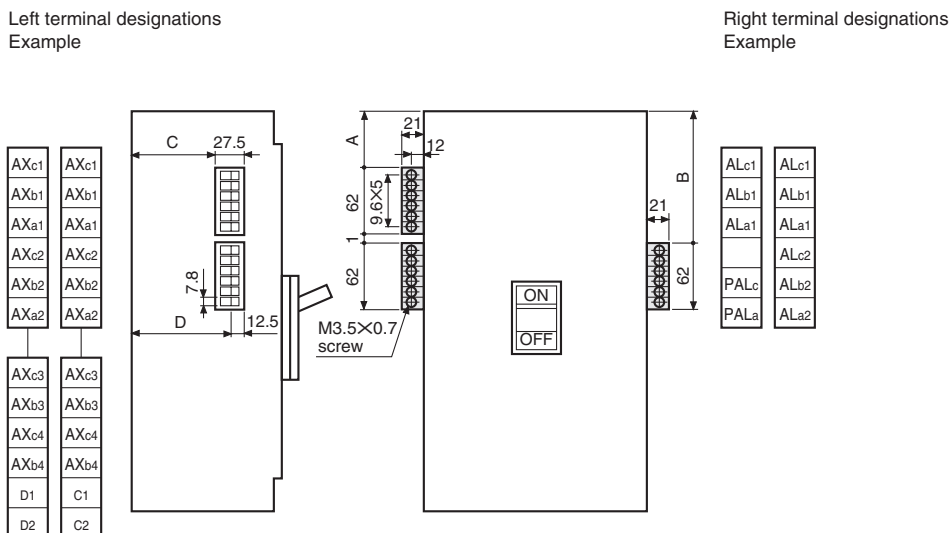

MCCB Type	A	B	C	D
S1250	51	114 (124)	57	72
S1600	51	114 (124)	77	92

Comments:
 1. Values in parentheses applies to 4-pole breakers.
 2. Tightening torque of M3.5 terminal screws: 0.9 – 1.2 N·m.
 3. Connection wire size: 2.0mm² max x 2.

DIMENSIONS

OCR Power Supply for Electronic Protection (Standard type)

MCCB Type

S250-NE, S250-GE,
S250-PE, H250-NE

Connection diagram

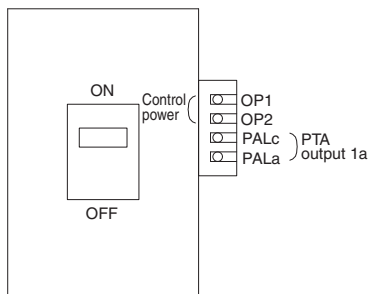

Notes: Separate installation of the OCR power supply is not available.

Mounting dimensions

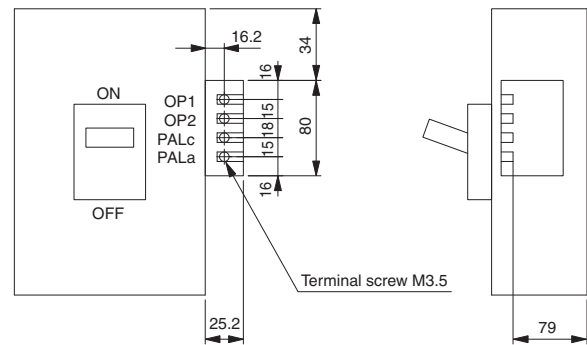

Notes: 1. Tightening torque of terminal screws: 0.9 – 1.2 N·m
2. Applicable wire size: 2.0 mm² max

OCR Power Supply for Electronic Protection (Standard type)

MCCB Type		A	B	C	D
S400-NE, S400-GE, S400-PE, E630-NE, S630-CE, S630-GE		71	74	25.2	16.2
H400-NE, L400-NE		71	111	25.2	16.2
S800, S1000		62.5	74	25.2	16.2
H800, L800		62.5	111	25.2	16.2
S1250	3P	33	72	21	12
	4P	43	72	21	12
S1600	3P	33	92	21	12
	4P	43	92	21	12

Connection diagram

OCR power supply installed on the breaker

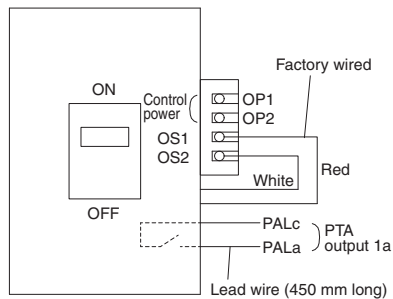

OCR power supply installed separately to the breaker

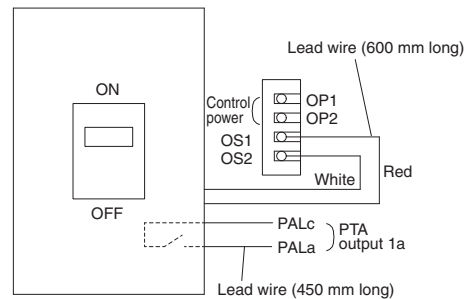

Mounting dimensions

OCR power supply installed on the breaker

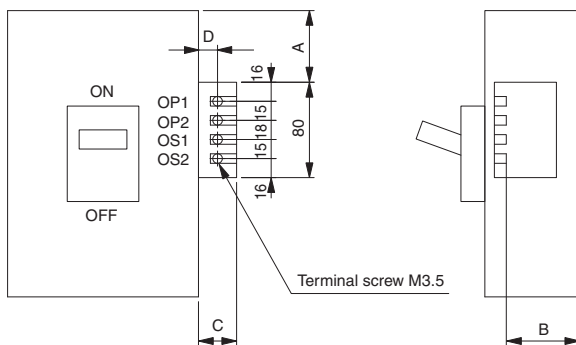

- Notes:**
1. Tightening torque of terminal screws: 0.9 – 1.2 N·m
 2. Applicable lead wire size: 2.0 mm² max

OCR power supply installed separately to the breaker

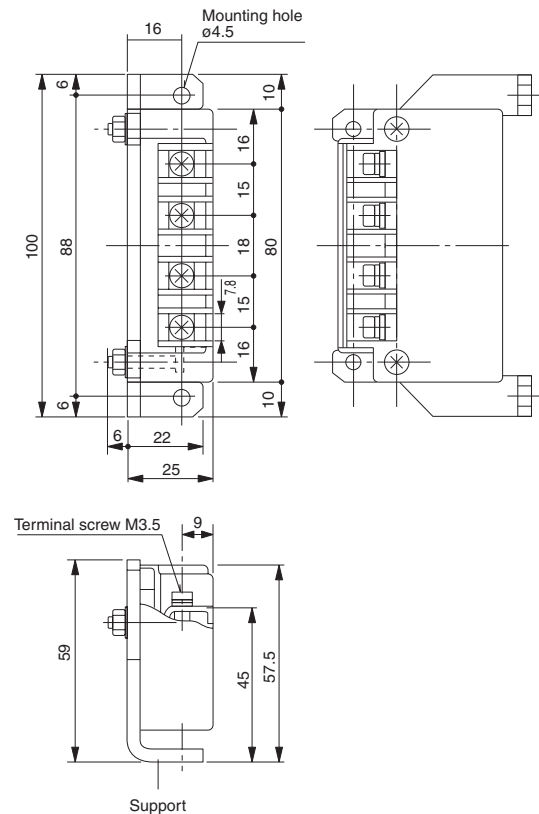

DIMENSIONS

OCR Power Supply for Electronic Protection (with LCD)

MCCB Type	A	B	C	D
S400-NE, S400-GE, S400-PE, E630-NE, S630-CE, S630-GE	80	74	25.2	16.2
H400-NE, L400-NE	80	111	25.2	16.2
S800, S1000	71.5	74	25.2	16.2
H800, L800	71.5	111	25.2	16.2

Connection diagram

OCR power supply installed on the breaker

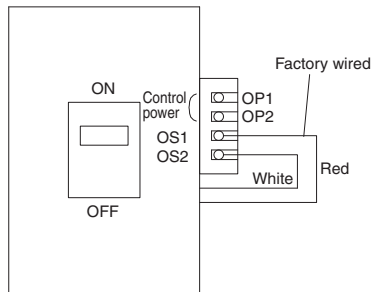

OCR power supply installed separately to the breaker

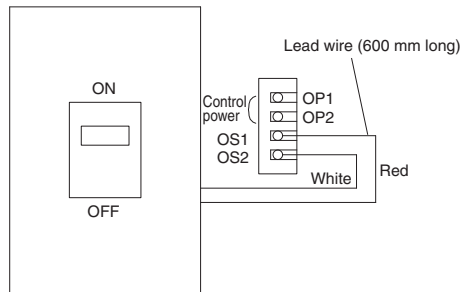

Mounting dimensions

OCR power supply installed on the breaker

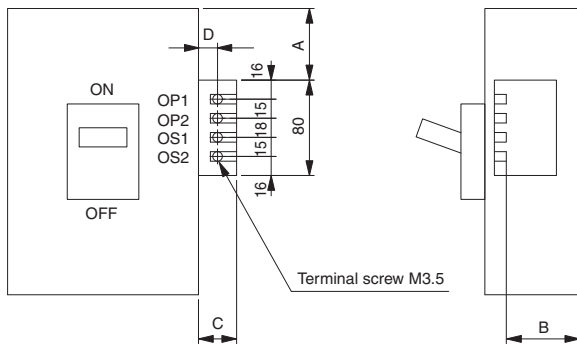

- Notes:** 1. Tightening torque of terminal screws: 0.9 – 1.2 N·m
2. Applicable lead wire size: 2.0 mm² max

OCR power supply installed separately to the breaker

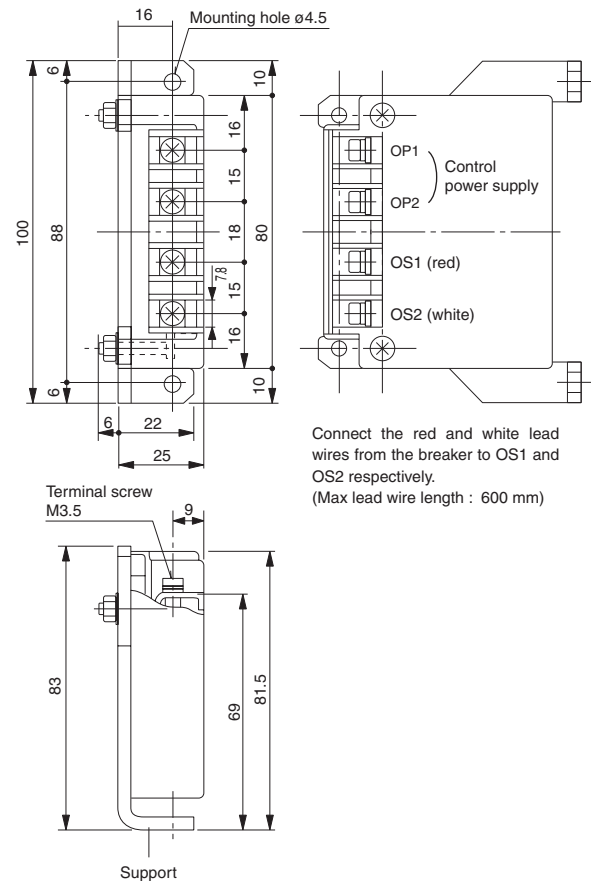

Slide Interlocks

ASL : Arrangement Standard Line

H_L : Handle Frame Centre Line

C_L : Handle Centre Line

Mechanical Interlocks slide type (MS)

For 125A frame size

MCCB Type	Poles	Conn.	Parts No.	A
E125, S125	3	FC, RC	T2MS123SF	91.7
	4	FC, RC	T2MS124SF	91.7

Panel Cutout

T2MS123SF

T2MS124SF

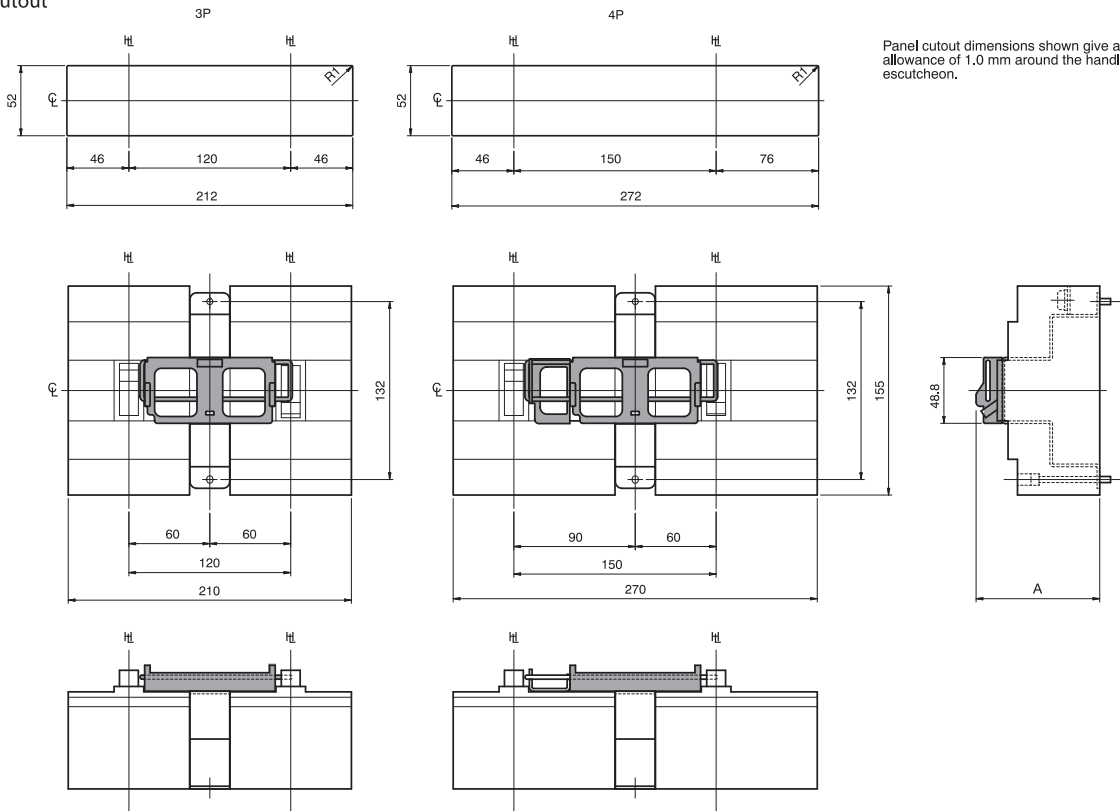

Drilling plan

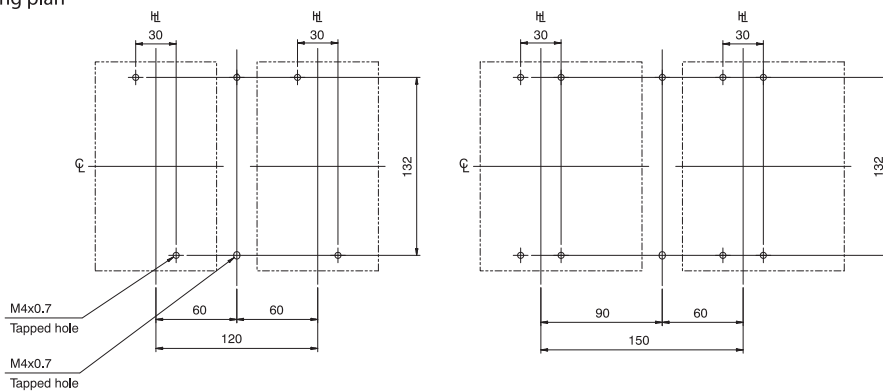

DIMENSIONS

Slide Interlocks

ASL : Arrangement Standard Line

HL : Handle Frame Centre Line

CL : Handle Centre Line

Mechanical Interlocks slide type (MS)

For 125A, 160A, 250A frame size

MCCB Type	Poles	Conn.	Parts No.	A
S160, E250, S250-NJ, S250GJ, S250-NN	3	FC, RC	T2MS253SF	91.7
	4	FC, RC	T2MS254SF	
H125, L125, H160, L160, S250-NE, S250-GE, S250-PE, H250, L250	3	FC, RC	T2MS253LF	126.7
	4	FC, RC	T2MS254LF	

Panel Cutout

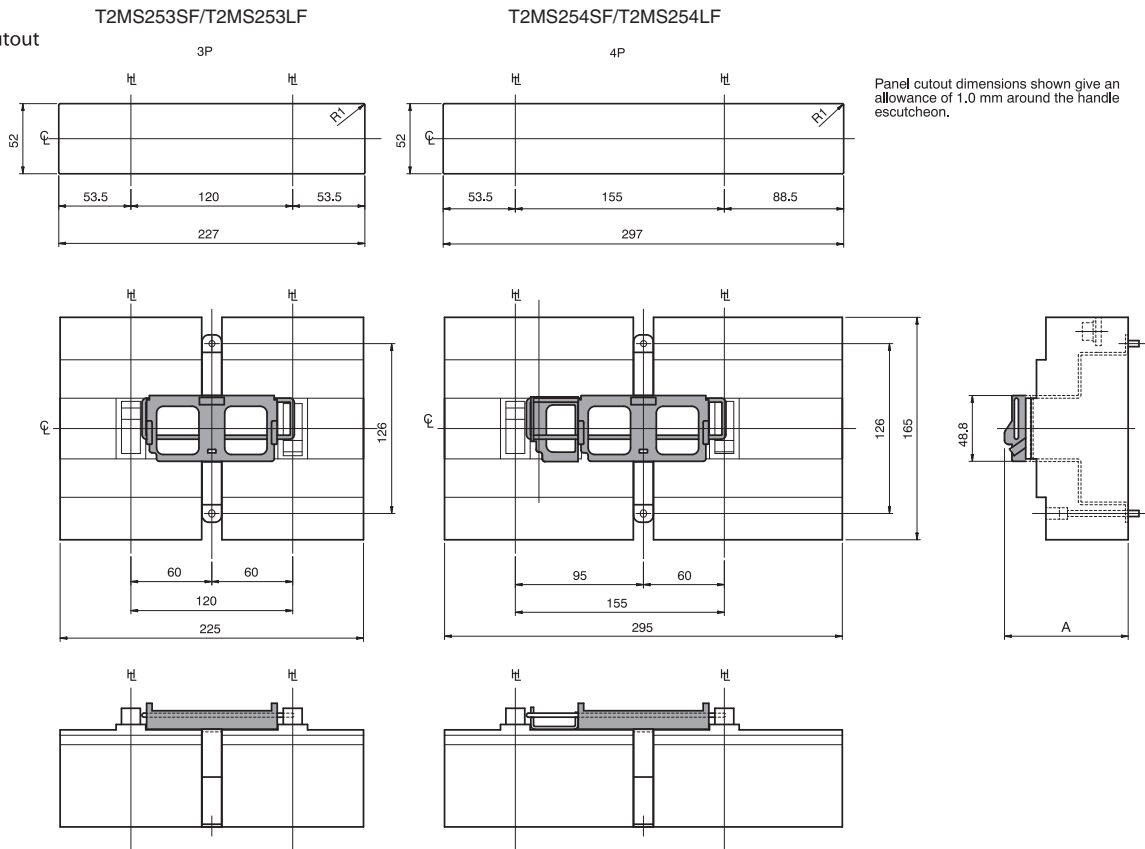

Drilling plan

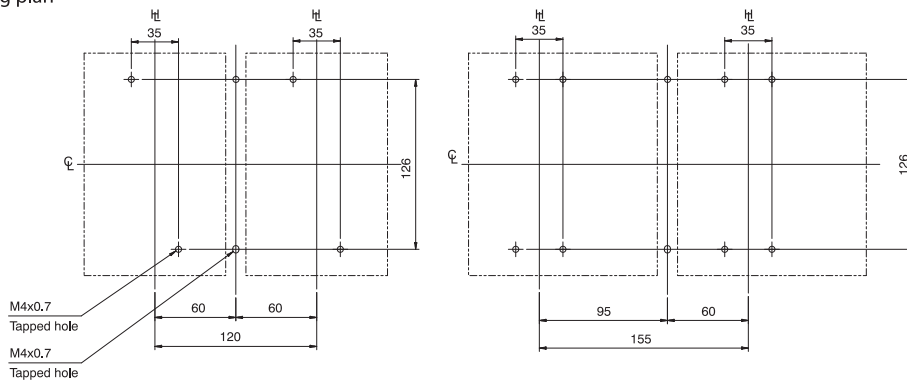

Slide Interlocks

ASL : Arrangement Standard Line

HL : Handle Frame Centre Line

CL : Handle Centre Line

Mechanical Interlocks slide type (MS)

For 400A, 630A frame size

MCCB Type	Poles	Conn.	Parts No.	A
E400, S400, E630, S630	3	FC, RC	T2MS403SF	135.5
	4	FC, RC	T2MS404SF	
H400, L400	3	FC, RC	T2MS403LF	172.5
	4	FC, RC	T2MS404LF	

T2MS403SF/T2MS403LF
Panel Cutout

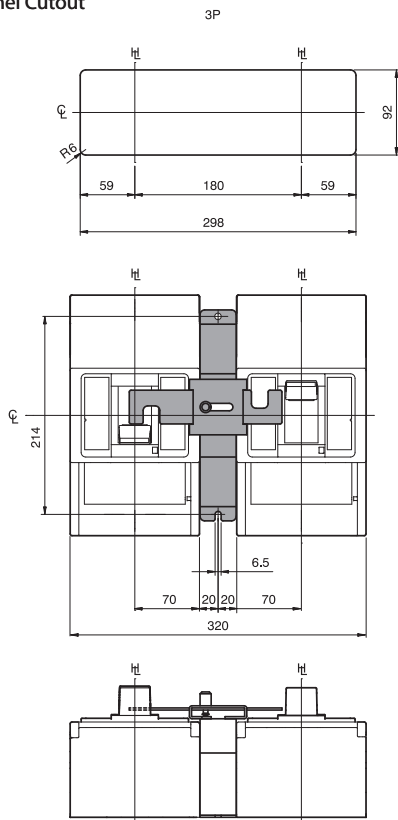

T2MS404SF/T2MS404LF
Panel Cutout

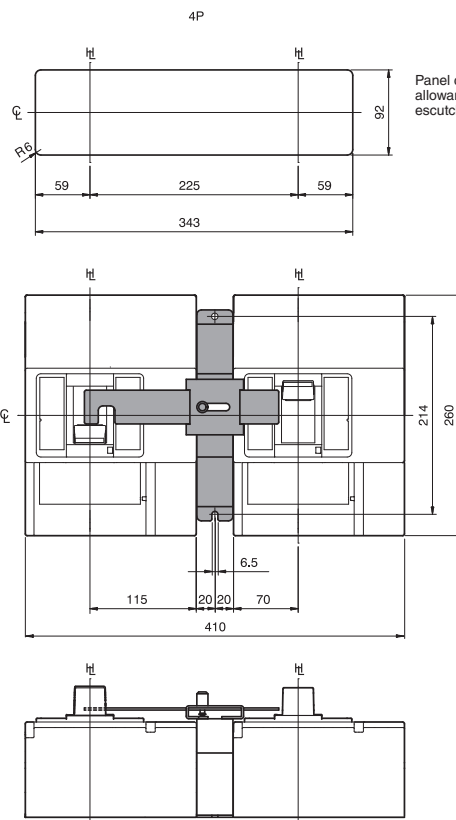

Panel cutout dimensions shown give an allowance of 1.0 mm around the handle escutcheon.

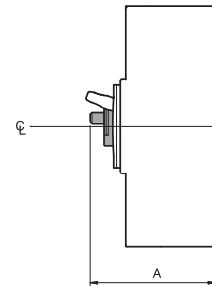

Drilling plan

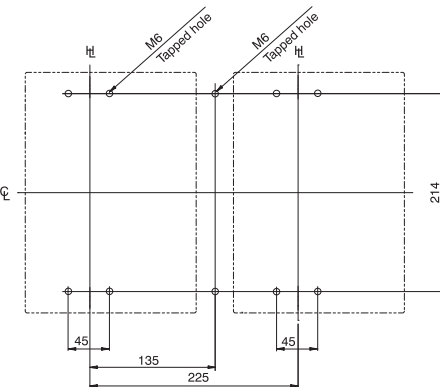
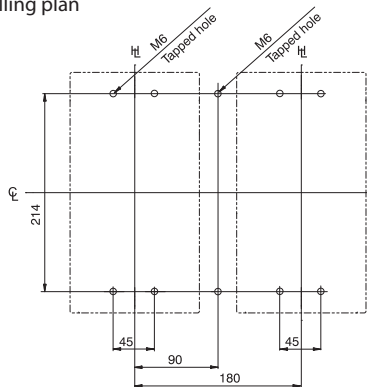

DIMENSIONS

Slide Interlocks

ASL : Arrangement Standard Line

HL : Handle Frame Centre Line

CL : Handle Centre Line

Mechanical Interlocks slide type (MS)

For 800A, 1000A frame size

MCCB Type	Poles	Conn.	Parts No.	A
S800, S1000	3	FC, RC	T2MS803SF	135.5
	4	FC, RC	T2MS804SF	
H800, L800	3	FC, RC	T2MS803LF	172.5
	4	FC, RC	T2MS804LF	

Notes:

(1) The interlock cannot be applied to breakers equipped with front extension bars due to the shortage of the insulating distance.

T2MS803SF/T2MS803LF
Panel Cutout

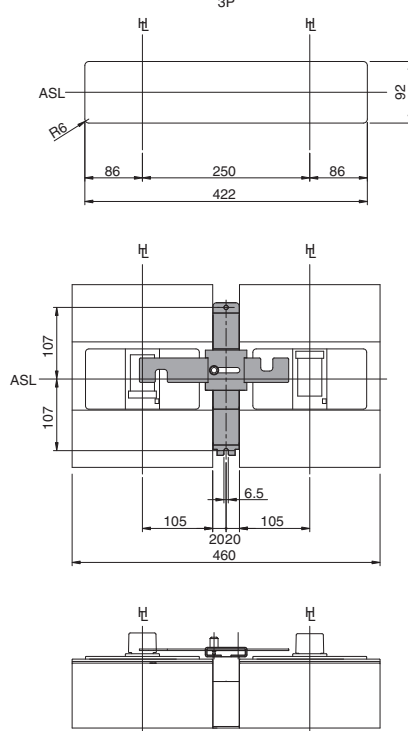

T2MS804SF/T2MS804LF

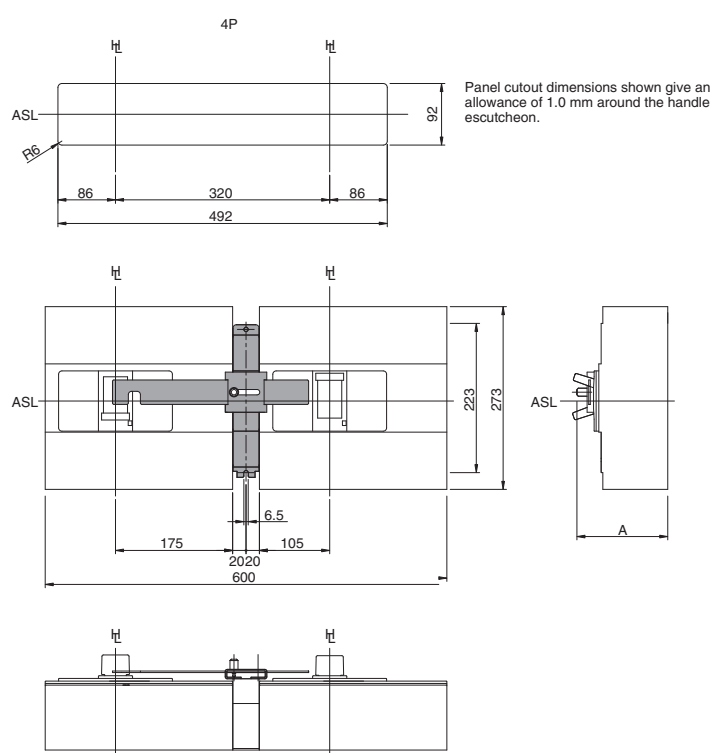

Panel cutout dimensions shown give an allowance of 1.0 mm around the handle escutcheon.

Drilling plan

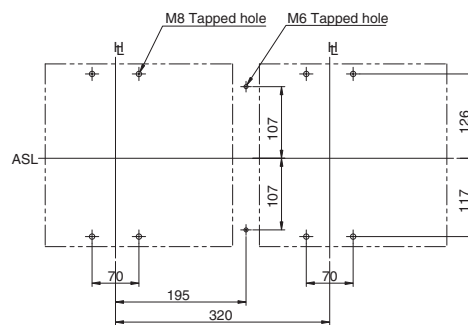
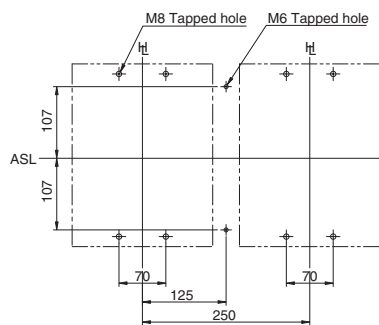

Slide Interlocks

MCCB Type	Parts No.	Poles	a	b	c	d	e	f	g	h	k	m	ℓ	R
S1250 (S1250-ND is excluded)	T2MSX63SF	3	220	340	135	61.5	343	64	74	138	430	160.5	30	8.5
	T2MSX64SF	4	290	410	135	61.5	413	64	74	138	570	160.5	30	8.5
TL-1250NE	XLF9 ①	3	220	340	129	61.5	343	58	74	132	430	179.6	30	8.5
		4	290	410	129	61.5	413	58	74	132	570	179.6	30	8.5
S1250-ND S1600	T2MSX63SF	3	220	340	135	61.5	343	64	74	138	430	180.5	30	8.5
	T2MSX64SF	4	290	410	135	61.5	413	64	74	138	570	180.5	30	8.5

Notes:

① : Please order with the breakers.

(1) The interlock cannot be applied to breakers equipped with a terminal block, UVT controller or OCR controller.

(2) See the outline dimensions of the breaker for the drilling plan.

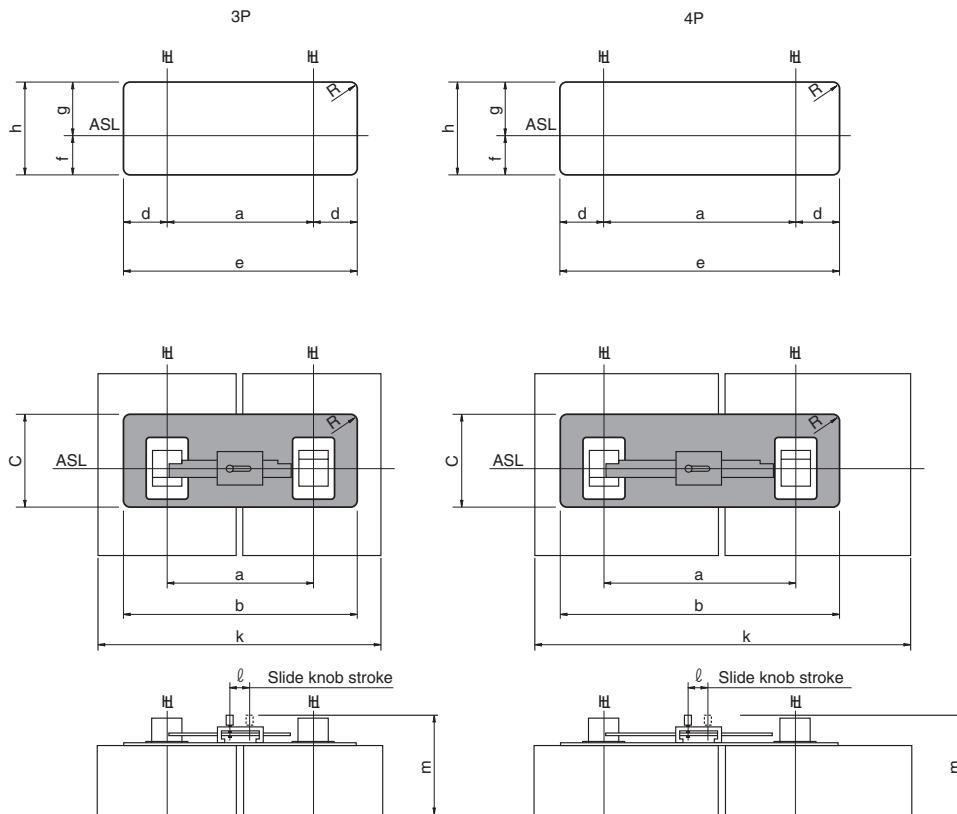

DIMENSIONS

Link Interlocks

ASL : Arrangement Standard Line

H_L : Handle Frame Centre Line

CL : Handle Centre Line

Mechanical Interlocks link type (ML)

For 125A frame size

MCCB Type	Poles	Position	Parts No.	A
E125, S125	3	Right	T2ML12RA	81.7
	4		T2ML12L3A	
	3	Left	T2ML12L4A	
	4		T2ML12L3A	

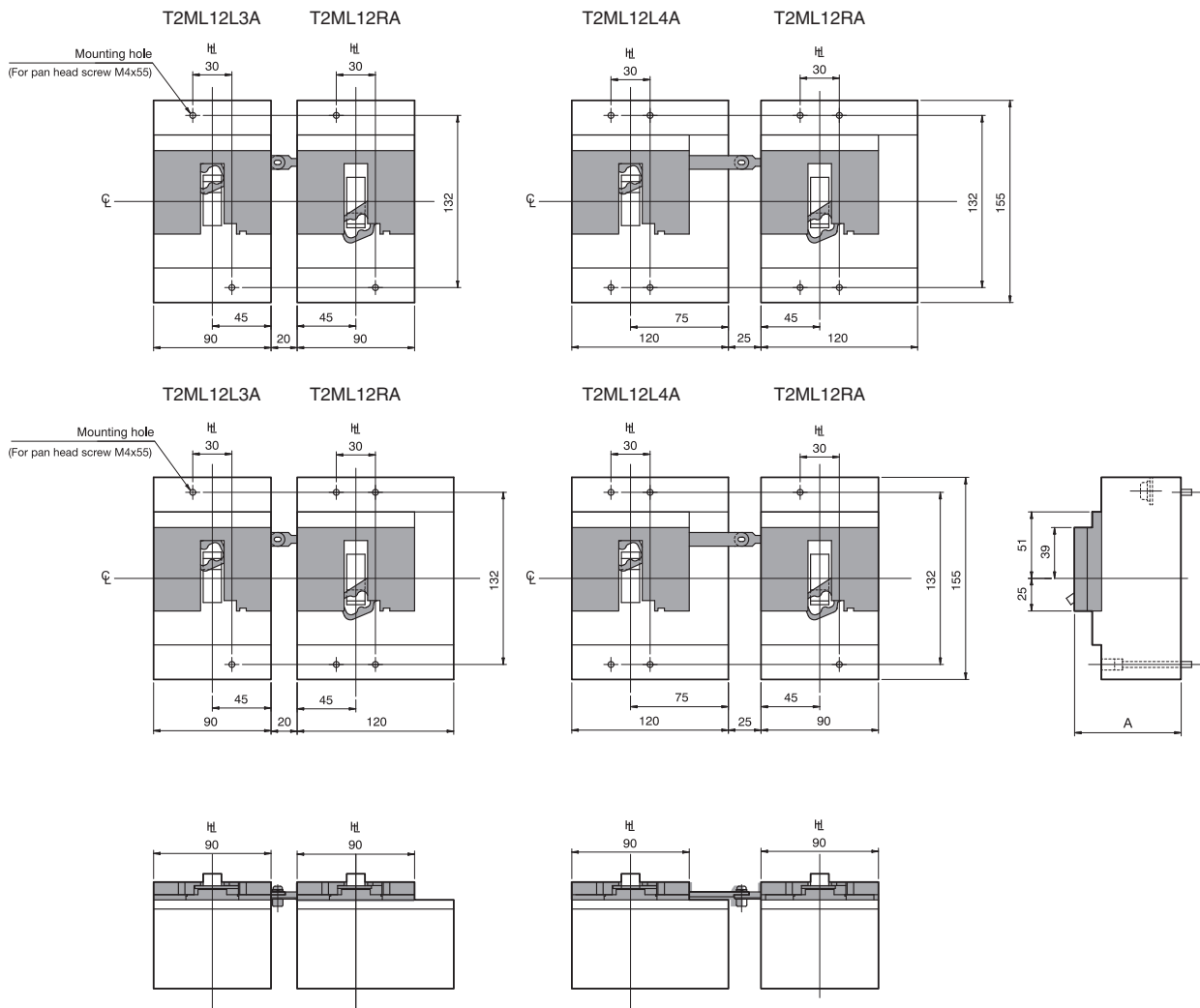

Link Interlocks

ASL : Arrangement Standard Line

H_L : Handle Frame Centre Line

Q : Handle Centre Line

Mechanical Interlocks link type (ML)

For 125A, 160A, 250A frame size

MCCB Type	Poles	Position	Parts No.	A
S160, E250, S250-NJ, S250-GJ, S250-NN	3	Right	T2ML25RA	81.7
	4		T2ML25L3A	
	3	Left	T2ML25L3A	
	4		T2ML25L4A	
H125, L125, H160, L160, S250-NE, S250-GE, S250-PE, H250, L250	3	Right	T2ML25RA	116.7
	4		T2ML25L3A	
	3	Left	T2ML25L3A	
	4		T2ML25L4A	

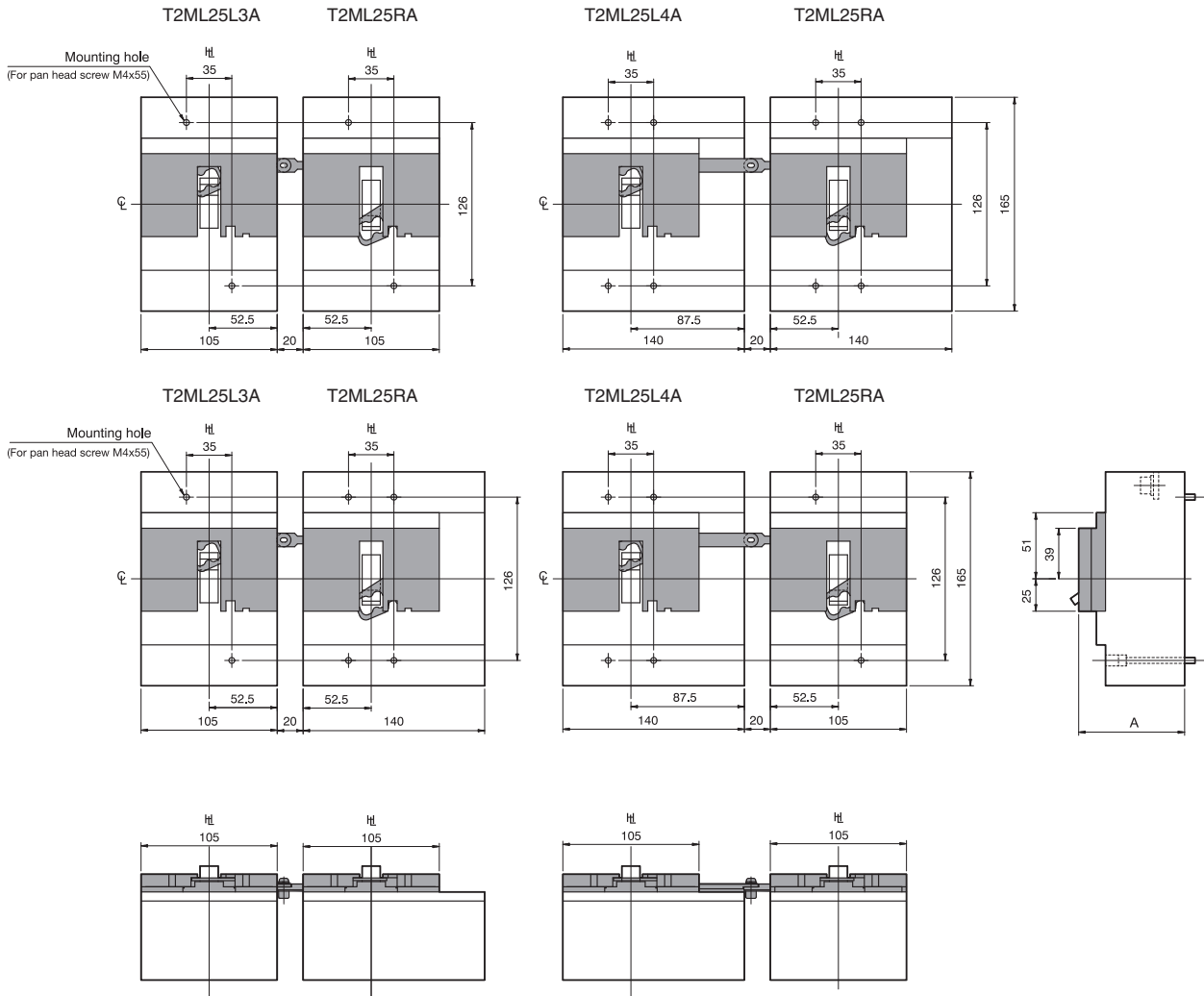

DIMENSIONS

Link Interlocks with motor operators

ASL : Arrangement Standard Line

HL : Handle Frame Centre Line

CL : Handle Centre Line

Mechanical Interlocks link type (ML)

For 400A, 630A frame size

MCCB Type	Poles	Position	Parts No.	A
E400, S400 E630, S630	3	Right	T2ML40RA	213
	4		T2ML40L3A	
	3	Left	T2ML40L4A	
	4		T2ML40L4A	
H400, L400	3	Right	T2ML40RA	250
	4		T2ML40L3A	
	3	Left	T2ML40L3A	
	4		T2ML40L4A	

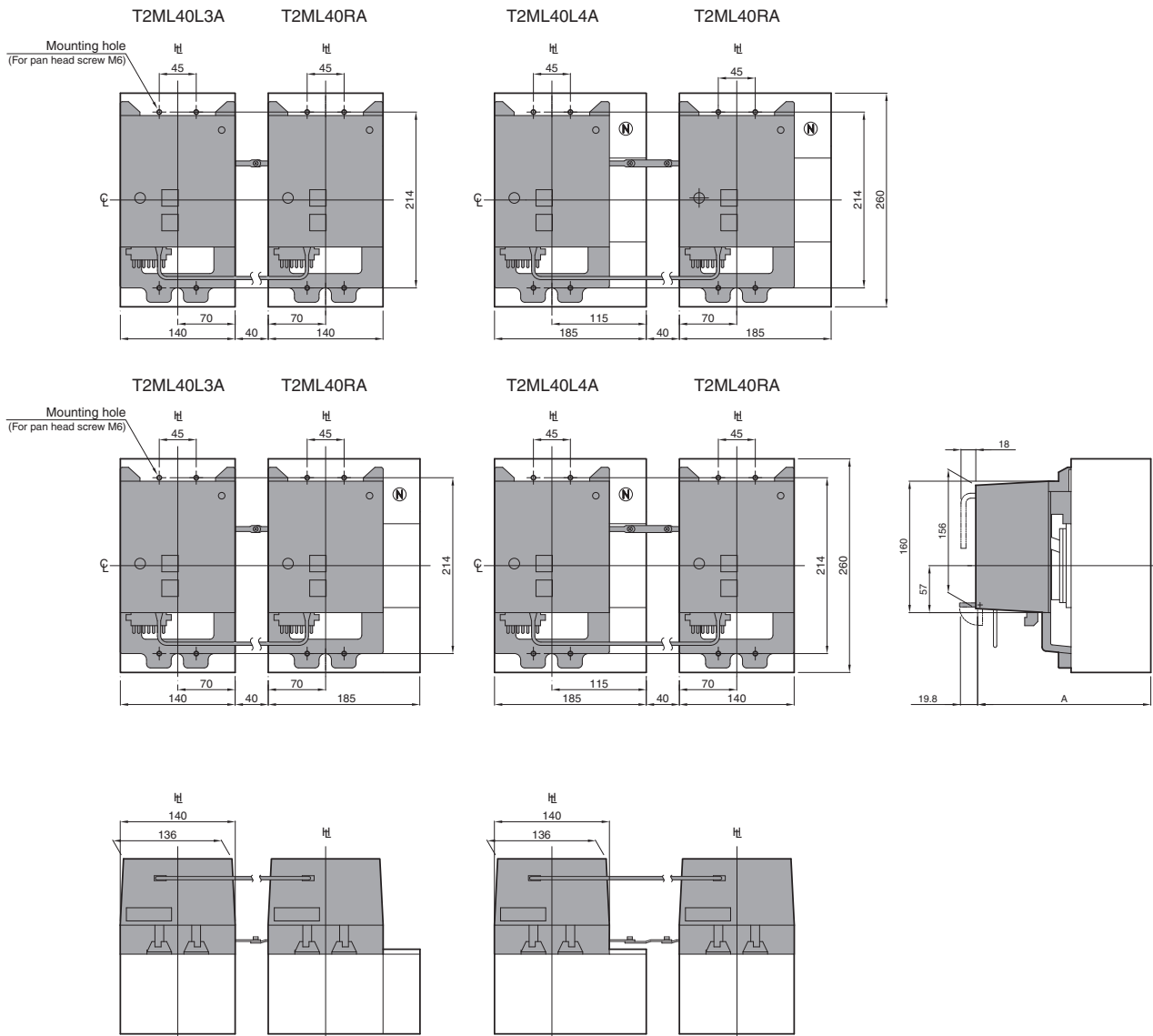

For 400A and 630A frame, the link mechanical interlocks can not be used without motor operators. Please specify also the motor operators when ordering. Furthermore, please request the additional labels for the breakers to TERASAKI and put the labels on the side of the breakers.

Link Interlocks with breaker mounted handles

ASL : Arrangement Standard Line

HL : Handle Frame Centre Line

CL : Handle Centre Line

Mechanical Interlocks link type (ML)

For 400A, 630A frame size

MCCB Type	Poles	Position	Parts No.	A	B
E400, S400 E630, S630	3	Right	T2ML40RA	200	150±2
	4		T2ML40L3A		
	3	Left	T2ML40L4A		
	4		T2ML40L3A		
H400, L400	3	Right	T2ML40RA	237	187±2
	4		T2ML40L3A		
	3	Left	T2ML40L4A		
	4		T2ML40L3A		

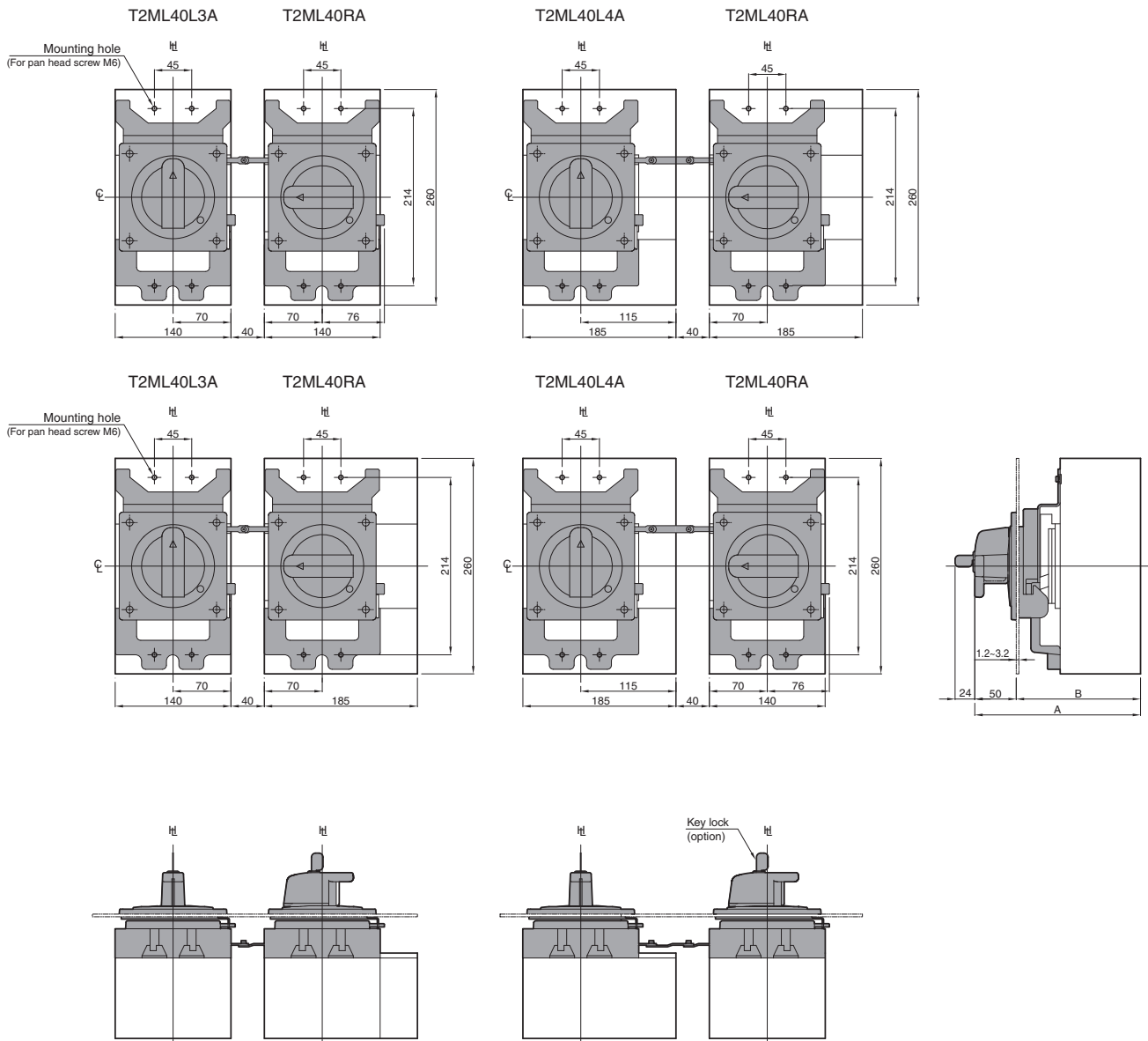

For 400A and 630A frame, the link mechanical interlocks can not be used without breaker mounted handles. Please specify also the breaker mounted handles when ordering. Furthermore, please request the additional labels for the breakers to TERA SAKI and put the labels on the side of the breakers.

DIMENSIONS

Link Interlocks with motor operators

ASL : Arrangement Standard Line

hl : Handle Frame Centre Line

Cl : Handle Centre Line

Mechanical Interlocks link type (ML)

For 800A, 1000A frame size

MCCB Type	Poles	Position	Parts No.	A
S800, S1000	3	Right	T2ML80RA	213
	4			
	3	Left	T2ML80L3A	
	4		T2ML80L4A	
H800, L800	3	Right	T2ML80RA	250
	4			
	3	Left	T2ML80L3A	
	4		T2ML80L4A	

Notes:

(1) The interlock cannot be applied to breakers equipped with terminal block.

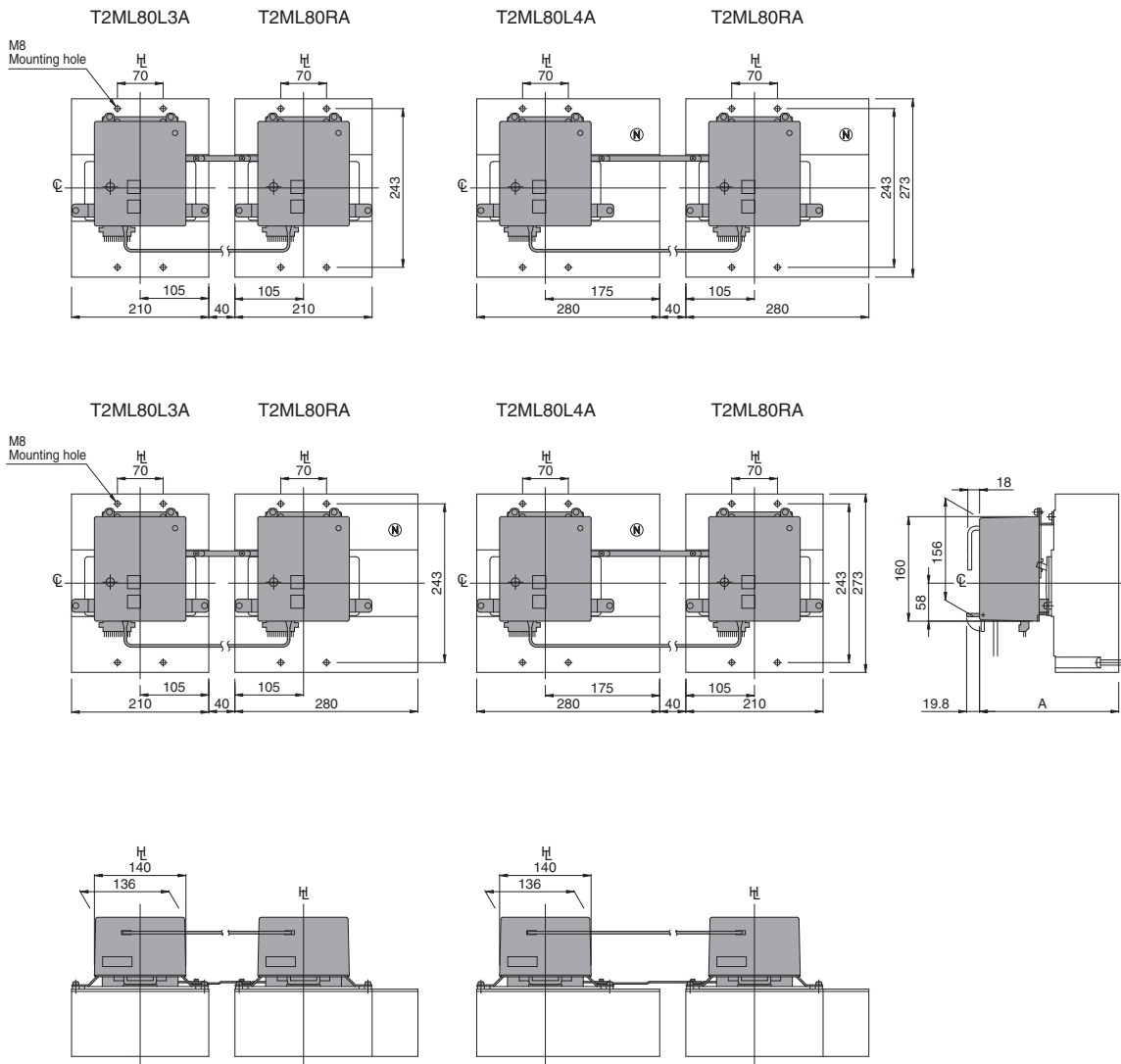

For 800A and 1000A frame, the link mechanical interlocks can not be used without motor operators. Please specify also the motor operators when ordering. Furthermore, please request the additional labels for the breakers to TERASAKI and put the labels on the side of the breakers.

Link Interlocks with breaker mounted handles

ASL : Arrangement Standard Line

HL : Handle Frame Centre Line

CL : Handle Centre Line

Mechanical Interlocks link type (ML)

For 800A, 1000A frame size

MCCB Type	Poles	Position	Parts No.	A	B
S800, S1000	3	Right	T2ML80RA	200	150
	4		T2ML80L3A		
	3	Left	T2ML80L4A		
	4		T2ML80L4A		
H800, L800	3	Right	T2ML80RA	237	187
	4		T2ML80L3A		
	3	Left	T2ML80L3A		
	4		T2ML80L4A		

Notes:

(1) The interlock cannot be applied to breakers equipped with terminal block.

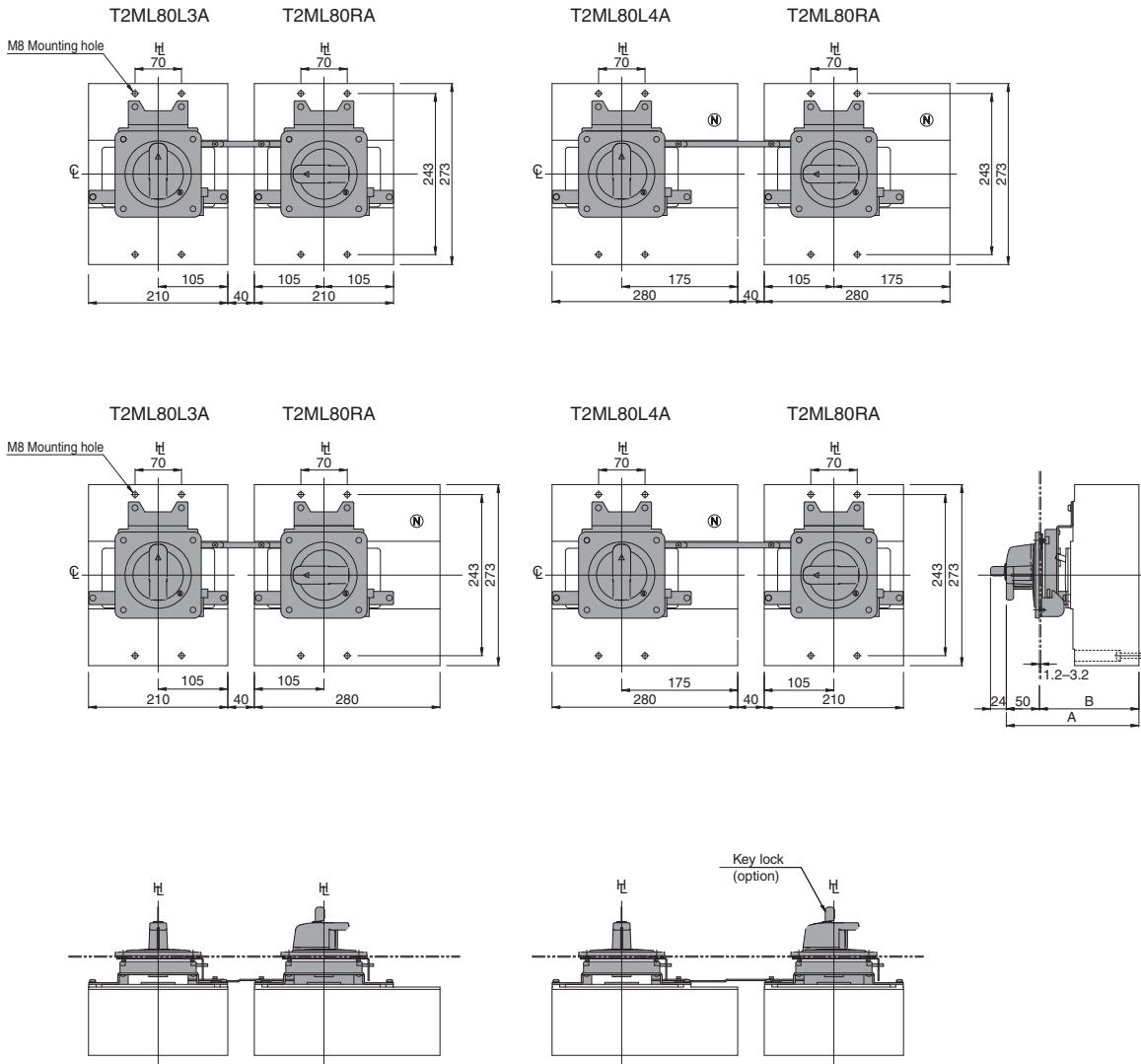

For 800A and 1000A frame, the link mechanical interlocks can not be used without breaker mounted handles. Please specify also the breaker mounted handles when ordering. Furthermore, please request the additional labels for the breakers to TERASAKI and put the labels on the side of the breakers.

DIMENSIONS

Wire Interlocks

ASL : Arrangement Standard Line

H_L : Handle Frame Centre Line

Q : Handle Centre Line

Mechanical Interlocks wire type (MW)

For 125A frame size

MCCB Type	Parts No.	A	Cable length	Parts No.	B	C
E125, S125	T2MW12CA	81.7	1.0m	T2MW00SA	130min. – 480max.	160min. – 480max.
			1.5m	T2MW00LA	130min. – 980max.	160min. – 980max.

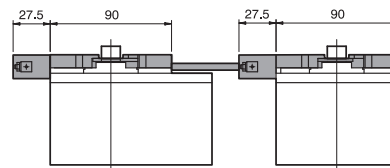
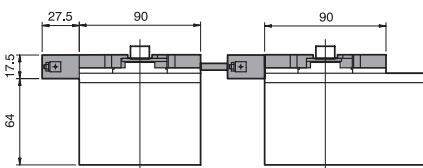
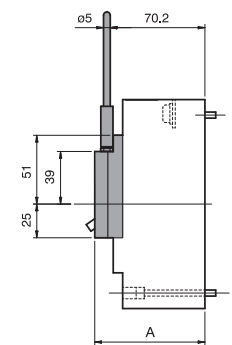
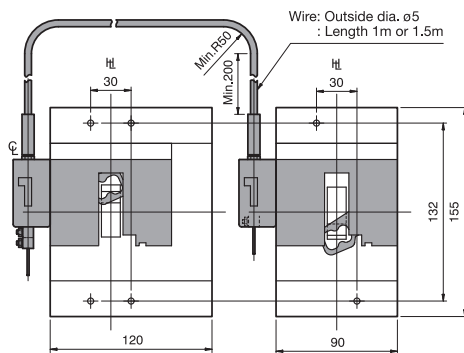
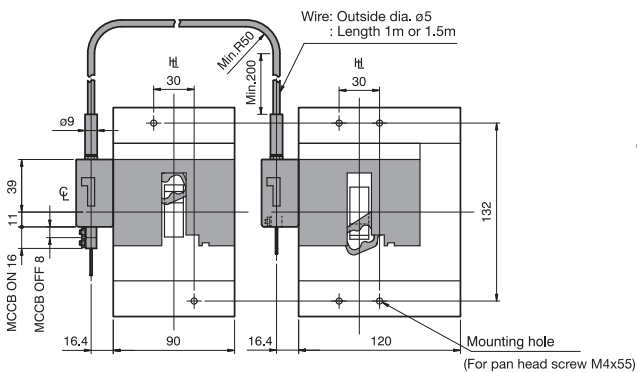
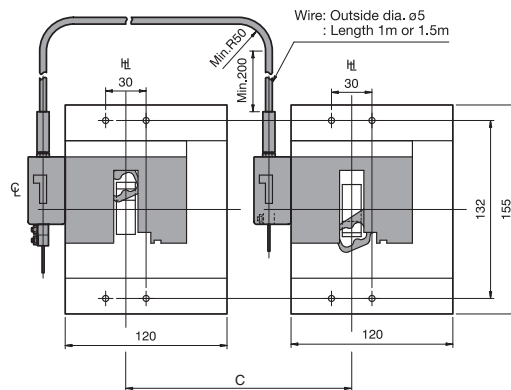
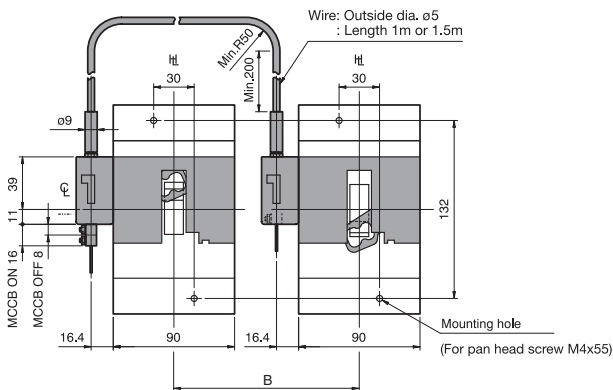

Wire Interlocks

ASL : Arrangement Standard Line

HL : Handle Frame Centre Line

CL : Handle Centre Line

Mechanical Interlocks wire type (MW)

For 125A, 160A, 250A frame size

MCCB Type	Parts No.	A	B	Cable length	Parts No.	B	C
S160, E250, S250-NJ S250-GJ, S250-NN	T2MW25CA	81.7	64	1.0m	T2MW00SA	155min. – 480max.	180min. – 480max.
H125, L125, H160, L160, S250-NE, S250-GE, S250-PE, H250, L250	T2MW25CA	116.7	99	1.5m	T2MW00LA	155min. – 980max.	180min. – 980max.

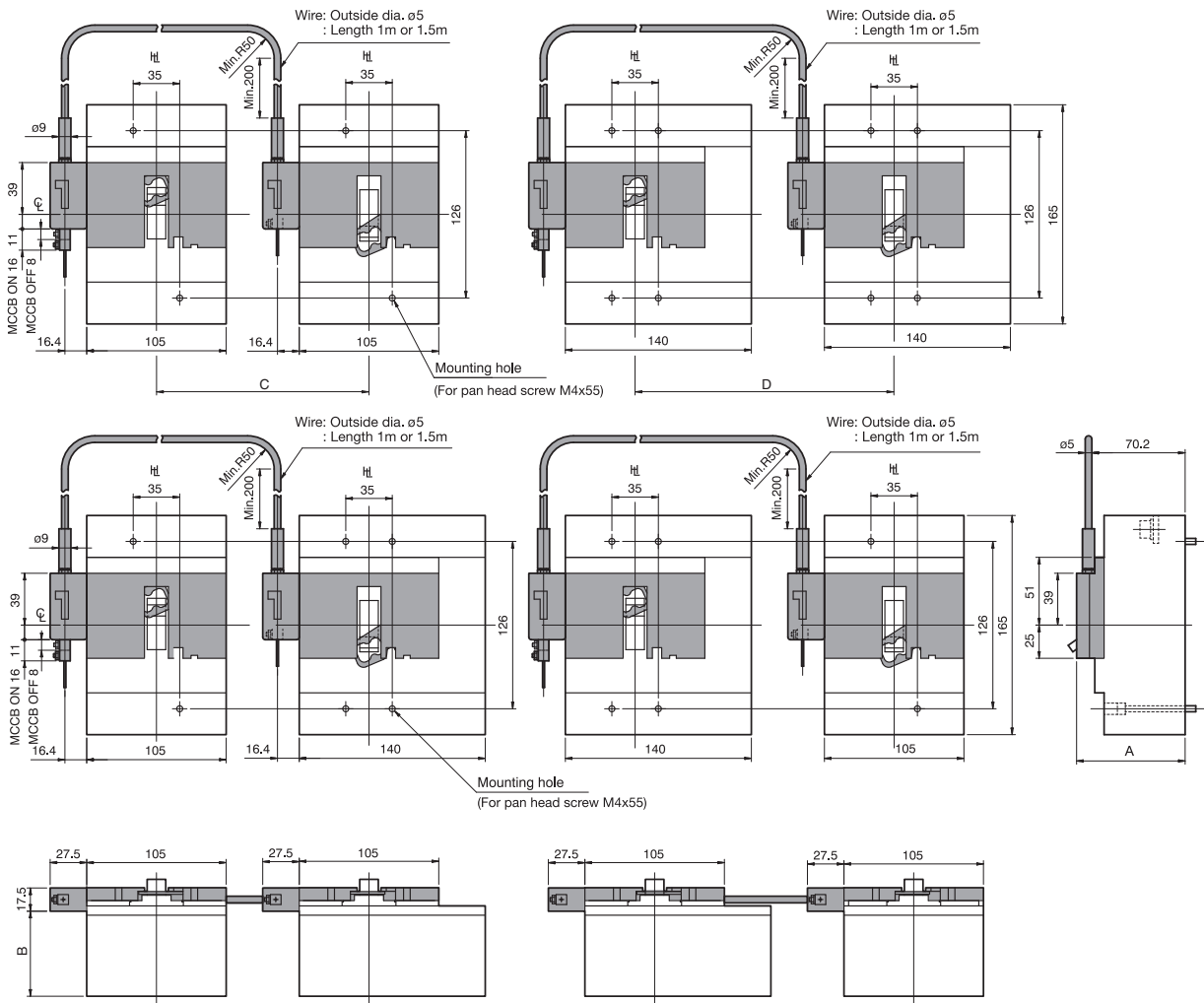

DIMENSIONS

Wire Interlocks with motor operators

ASL : Arrangement Standard Line

H_L : Handle Frame Centre Line

Q : Handle Centre Line

Mechanical Interlocks wire type (MW)

For 400A, 630A frame size

MCCB Type	Parts No.	A	B
E400, S400, E630, S630	T2MW40CA	213	105.4
H400, L400	T2MW40CA	250	142.4

Cable length	Parts No.	B	C
1.0m	T2MW00SA	180min. – 480max.	225min. – 480max.
1.5m	T2MW00LA	180min. – 930max.	225min. – 930max.

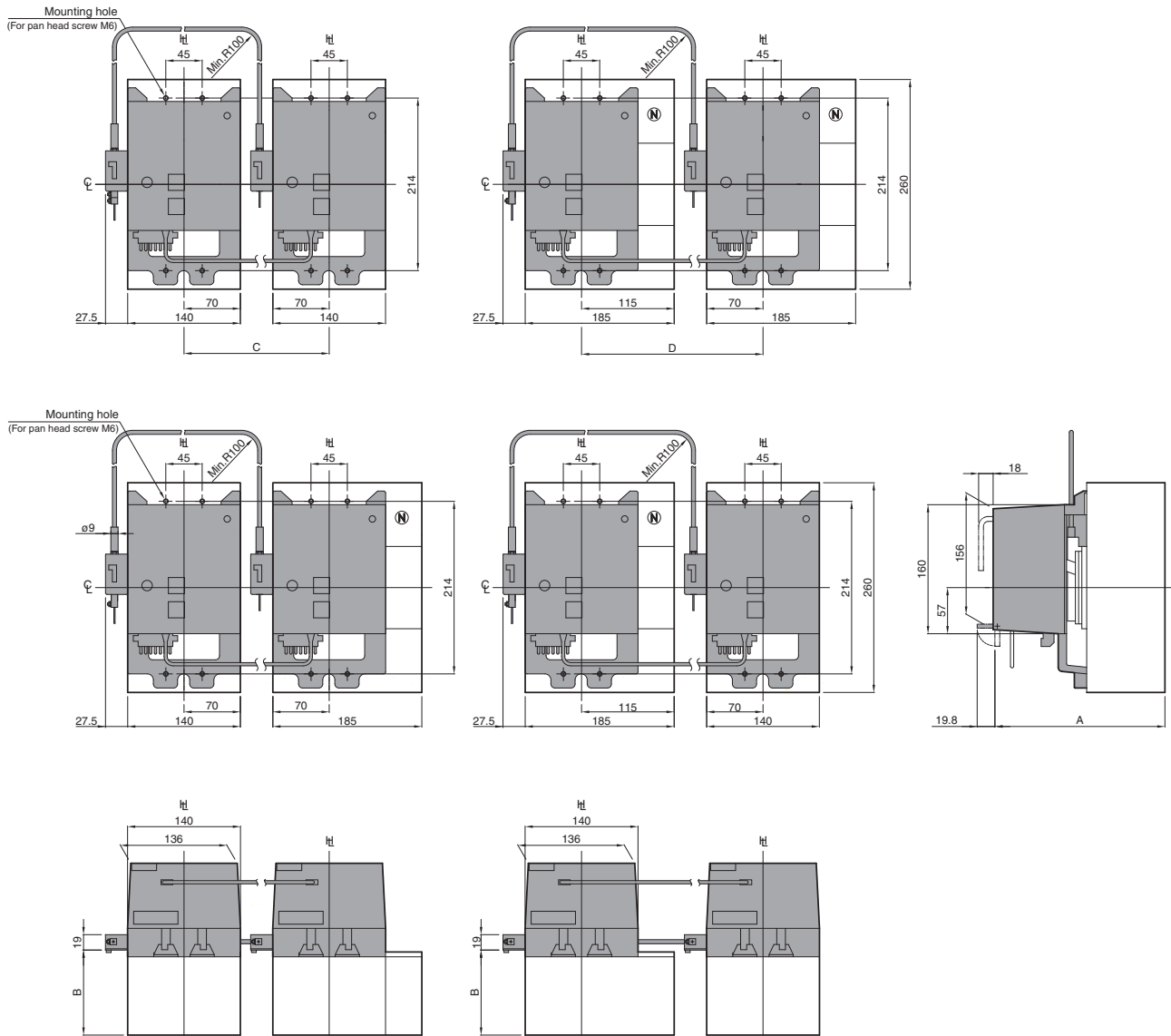

For 400A and 630A frame, the wire mechanical interlocks can not be used without motor operators. Please specify also the motor operators when ordering. Furthermore, please request the additional labels for the breakers to TERASAKI and put the labels on the side of the breakers.

Wire Interlocks with breaker mounted handles

ASL : Arrangement Standard Line

H_L : Handle Frame Centre Line

Q : Handle Centre Line

Mechanical Interlocks wire type (MW)

For 400A, 630A frame size

MCCB Type	Parts No.	A	B	Cable length	Parts No.	B	C
E400, S400, E630, S630	T2MW40CA	200	150±2	1.0m	T2MW00SA	180min. – 430max.	225min. – 430max.
H400, L400	T2MW40CA	237	187±2	1.5m	T2MW00LA	180min. – 930max.	225min. – 930max.

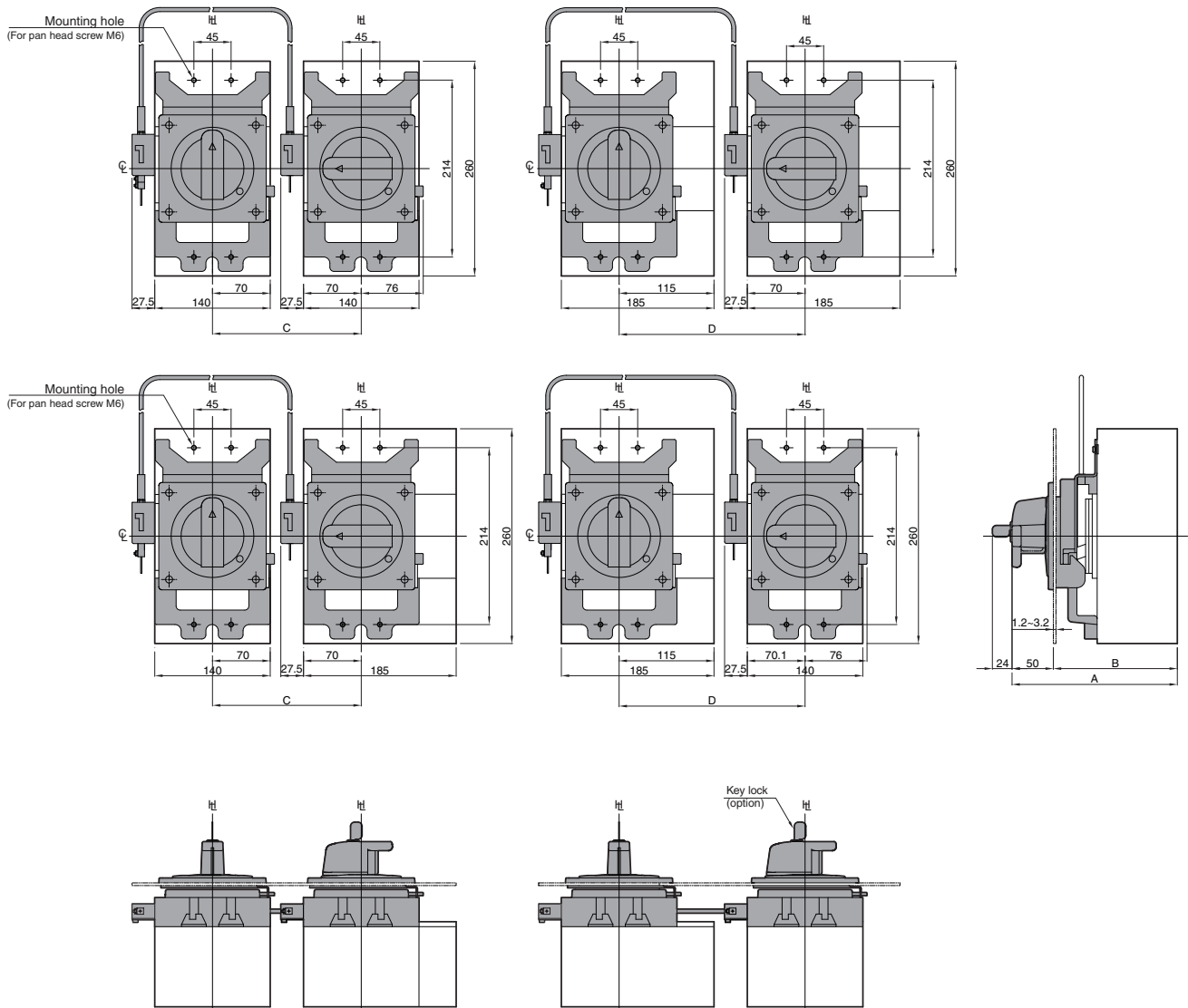

For 400A and 630A frame, the wire mechanical interlocks can not be used without breaker mounted handles. Please specify also the breaker mounted handles when ordering. Furthermore, please request the additional labels for the breakers to TERA SAKI and put the labels on the side of the breakers.

DIMENSIONS

Wire Interlocks with motor operators

ASL: Arrangement Standard Line

hl: Handle Frame Centre Line

Cl: Handle Centre Line

Mechanical Interlocks wire type (MW)

For 800A, 1000A frame size

MCCB Type	Parts No.	A	Cable length	Parts No.	C	D
S800, S1000	T2MW80CA	213	1.0m	T2MW00S	250min. – 430max.	320min. – 430max.
H800, L800	T2MW80CA	250	1.5m	T2MW00L	250min. – 930max.	320min. – 930max.

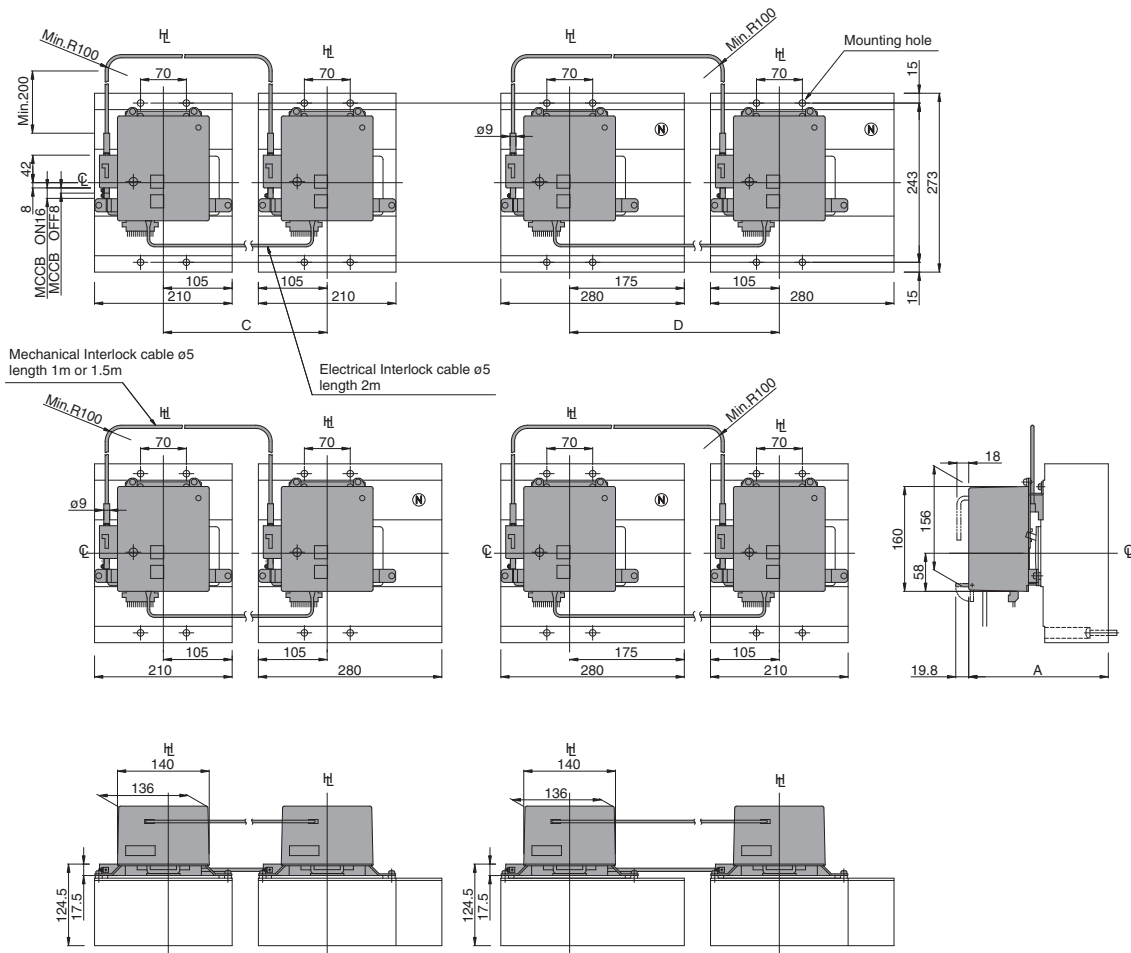

For 800A and 1000A frame, the wire mechanical interlocks can not be used without motor operators. Please specify also the motor operators when ordering. Furthermore, please request the additional labels for the breakers to TERASAKI and put the labels on the side of the breakers.

Wire Interlocks with breaker mounted handles

ASL : Arrangement Standard Line

HL : Handle Frame Centre Line

CL : Handle Centre Line

Mechanical Interlocks wire type (MW)

For 800A, 100A frame size

MCCB Type	Parts No.	A	B	Cable length	Parts No.	C	D
S800, S1000	T2MW80CA	200	150±2	1.0m	T2MW00S	250min. – 430max.	320min. – 430max.
H800, L800	T2MW80CA	237	187±2	1.5m	T2MW00L	250min. – 930max.	320min. – 930max.

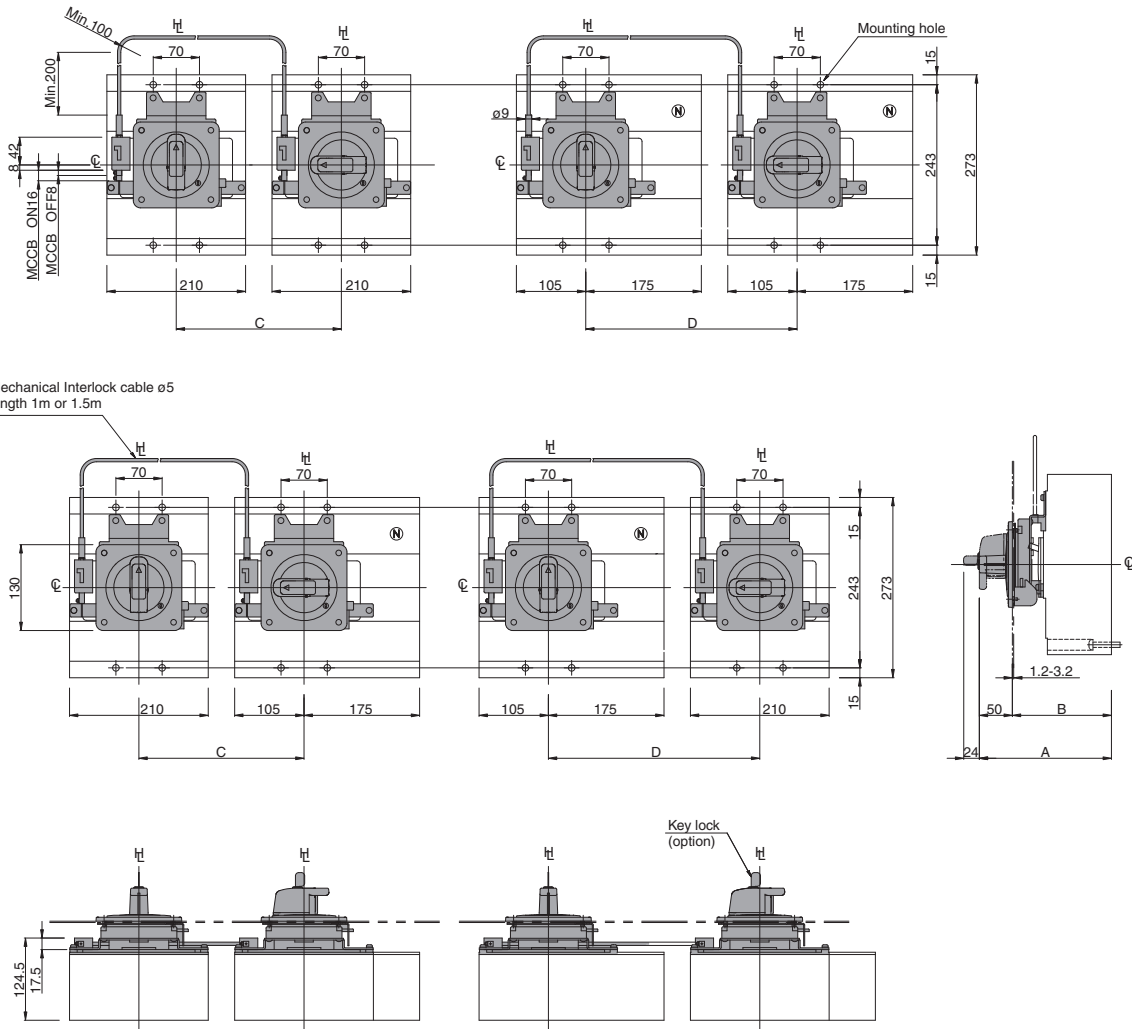

For 800A and 1000A frame, the wire mechanical interlocks can not be used without breaker mounted handles. Please specify also the breaker mounted handles when ordering. Furthermore, please request the additional labels for the breakers to TERA SAKI and put the labels on the side of the breakers.

DIMENSIONS

Wire Interlocks rear type

ASL: Arrangement Standard Line

H_L: Handle Frame Centre Line

Q: Handle Centre Line

Mechanical Interlocks wire type (MW)

For 1250A, 1600A frame size

MCCB Type	Parts No.	A
S1250 (S1250-ND is excluded)	Factory fitted	120
S1250-ND, S1600		140

Cable length	Parts No.	P	L
1.0m	T2MW00S	650-500-350	450-500-530 ±30
1.5m	T2MW00L	1000-900-750	550-600-700 ±30

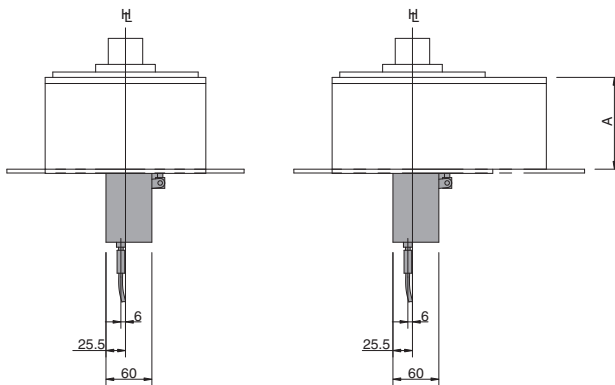
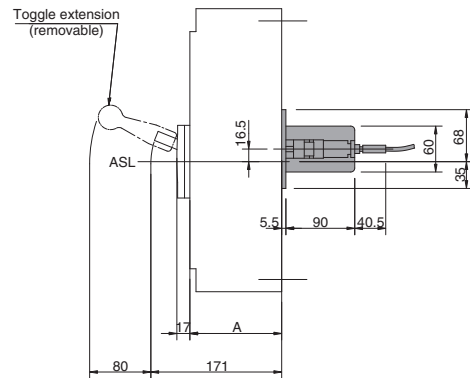
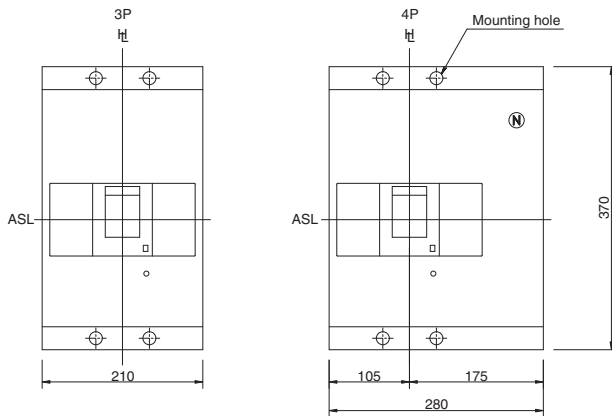

Drilling plan (front view)

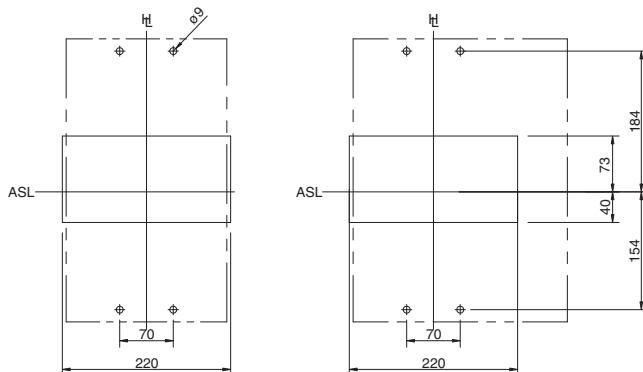

Vertical installation

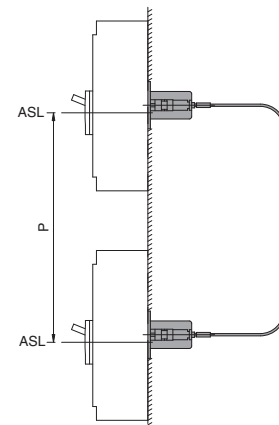

Horizontal installation

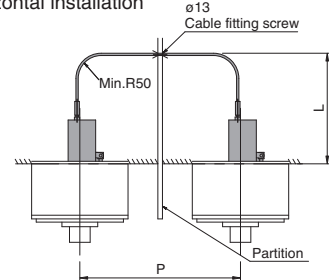

Position of Trip Button

Positions of Trip Button

ASL : Arrangement Standard Line

H_L : Handle Frame Centre Line

C_L : Handle Centre Line

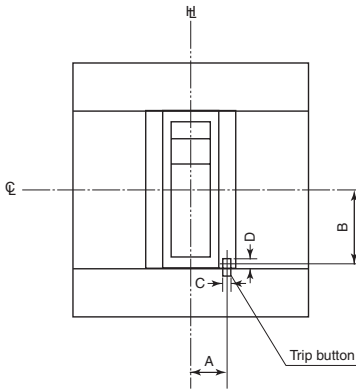

MCCB Type	Poles	A	B	C	D
E125, S125	3, 4	13.8	20.4	3.3	4.3
S160, E250, S250-NJ, S250-GJ, S250-NN,	3, 4	17.2	20.4	3.3	4.3
H125, L125, H160, L160, S250-NE, S250-GE, S250-PE, H250, L250	3, 4	17.2	20.4	3.3	4.3
E400, S400 H400, L400, E630, S630	3, 4	21.6	37.2	5.3	6.6
S800, S1000 H800, L800	3, 4	21.6	33	5.3	6.6

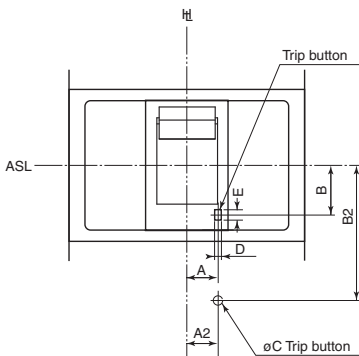

MCCB Type	Poles	A	B	A2	B2	C	D	E
S1250 S1600	3, 4	30	37.5	31	70.5	6	6	8

DIMENSIONS

External Neutral CT

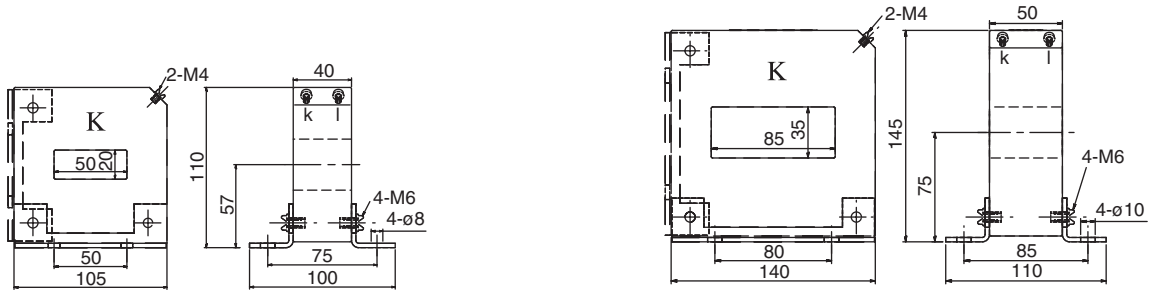

Type of CT	Rated primary current (A)	Rated secondary current (mA)
T2GB40N04	400	100
T2GB40N06	630	100
T2GB40N08	800	100

Type of CT	Rated primary current (A)	Rated secondary current (mA)
T2GBX6N10	1000	100
T2GBX6N12	1250	100
T2GBX6N16	1600	100

Door Flanges

Door flanges are recommended to be used to cover the cutout of a switchboard panel.

Door Flange for toggle-operated MCCBs (mm)

MCCB Type	Parts No.	Fig.	A	B	C	D	E	F		G		H		K	d	t
								Min	Max	Min	Max	Min	Max			
E125, S125	T2DF25	1 ①	77.5	77.5	105	50	92	37	42	37	42	32	45	—	M3×0.5	2
H125, L125, H160, L160, S250-NE, S250-GE, S250-PE, H250, L250	T2DF25	1 ①	82.5	82.5	105	50	92	37	42	37	42	32	45	—	M3×0.5	2
S160, E250, S250-NJ, S250-GJ, S250-NN	T2DF25	1 ①	82.5	82.5	105	50	92	37	42	37	42	32	45	—	M3×0.5	2
E400, S400, E630, S630	T2DF40	2 ①	130	130	135	95	120	48	56	48	56	57	90	80	M3×0.5	2
H400, L400	T2DF40	2 ①	130	130	135	95	120	48	56	48	56	57	90	80	M3×0.5	2
S800, S1000	T2DF40	2 ②	132	141	135	95	120	48	56	48	56	57	90	80	M3×0.5	2
H800, L800	T2DF40	2 ②	132	141	135	95	120	48	56	48	56	57	90	80	M3×0.5	2
S1250	T2DFX6	2 ②	170	200	150	120	135	51	63.5	51	63.5	85	115	80	M3×0.5	2
S1600	T2DFX6	2 ②	170	200	150	120	135	51	63.5	51	63.5	85	115	80	M3×0.5	2

Notes:

- ① : ϕ Handle centre line is applied.
- ② : ASL Arrangement standard line is applied.

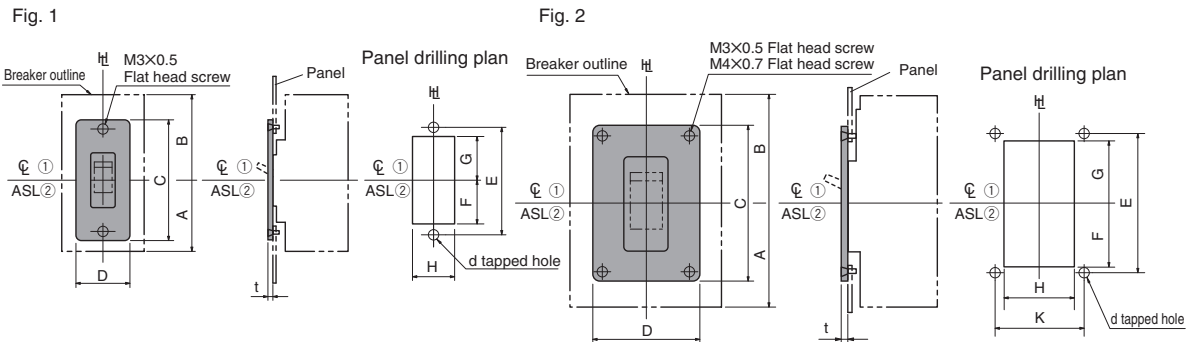

Door Flange for motor-operated MCCBs (mm)

MCCB Type	Parts No.	A	B	C	D	E	F		G		H		K	d	t
							Min	Max	Min	Max	Min	Max			
E125 S125	T2DM25	77.5	77.5	200	130	151	80	90	80	90	94	98	106	4	3.5
H125, L125, H160, L160 S250-NE, S250-GE, S250-PE H250, L250	T2DM25	77.5	77.5	200	130	151	80	90	80	90	94	98	106	4	3.5
S160, E250, S250-NJ, S250-GJ, S250-NN	T2DM25	77.5	77.5	200	130	151	80	90	80	90	94	98	106	4	3.5
E400, S400 E630, S630	T2DM40	57	103	200	180	150	59	69	105	115	144	148	156	4	3.5
H400, L400	T2DM40	57	103	200	180	150	59	69	105	115	144	148	156	4	3.5
S800, S1000	T2DM40	58	102	200	180	150	60	70	104	114	144	148	156	4	3.5
H800, L800	T2DM40	58	102	200	180	150	60	70	104	114	144	148	156	4	3.5

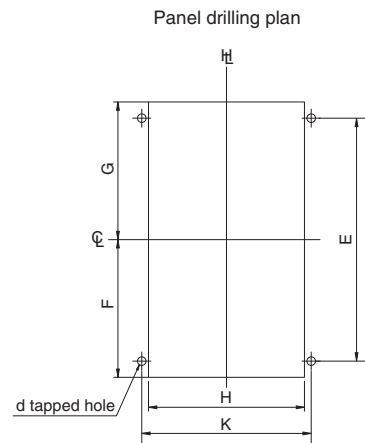
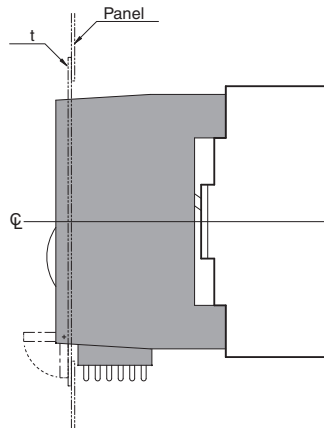
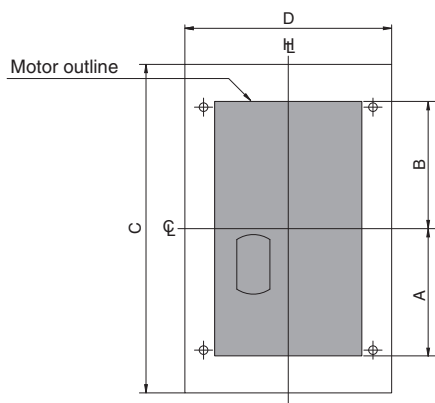

DIRECT OPENING



Under the heading “Measures to minimise the risk in the event of failure”, IEC 60204-1 Safety of Machinery-Electrical Equipment Machinery includes the following recommendation:

“-the use of switching devices having positive (or direct) opening operation.”



TEMBREAK 2 FIXED THERMAL MOULDED CASE CIRCUIT BREAKERS

TEMBREAK 2

MOULDED CASE CIRCUIT BREAKERS 16A TO 1600A

1. Welcome to TemBreak 2
2. Ratings and Specifications
3. Operating Characteristics
4. Application Data
5. Accessories
6. Installation
7. Dimensions

TEMBREAK 2

FIXED THERMAL MOULDED CASE CIRCUIT BREAKERS 15A TO 800A

8. Characteristics and Outline Dimensions

• S100-NF, S100-GF	181
• S125-NF, S125-GF	183
• S225-NF, S225-GF	185
• S250-NF, S250-GF	187
• H100-NF, L100-NF	189
• H125-NF, L125-NF	191
• H225-NF, L225-NF	193
• H250-NF, L250-NF	195
• E400-NF	197
• S400-CF, S400-NF, S400-GE, S400-PF	199
• S800-CF, S800-NF, S800-RF	201



8

Characteristics and Outline Dimensions *TemBreak2*

Molded Case Circuit Breakers

(100A Frame)

S100-NF, S100-GF

Ratings and Specifications

Type	S100-NF			S100-GF		
	2	3	4	2	3	4
Number of poles						
■ Ratings						
Rated current, A	15	50		15	60	
Calibrated at 40°C	20	60		20	75	
	30	75		30	100	
	40	100		40		
				50		
Rated insulation voltage [U_i] V AC						
	690			690		
Rated impulse withstand voltage [U_{imp}] kV						
	8			8		
■ Rated breaking capacity, kA						
IEC60947-2	AC	690V	6/6	6/6		
<i>I_{cu}/I_{cs}(sym)</i>		500V	22/22	25/22		
		440V	25/25	50/25		
		415V	30/30	65/33		
		380V	30/30	65/33		
		240V	50/50	85/85		
	① DC		250V	25/19	40/40	
		125V	40/30	40/40		
■ Rated short time withstand current, kA						
Weight (● marked standard type) kg	0.7	1.1	1.4	0.7	1.1	1.4
■ Connections and Mountings						
Front-connected (FC)	Terminal screws			Terminal screws		
	With extension bars			With extension bars		
	○ (BAR)			○ (BAR)		
Rear-connected (RC)	Bolt studs			Bolt studs		
	Flat bar studs			Flat bar studs		
Plug-in (PM)	○			○		
Draw-out type (DR)	—			—		
DIN rail mount	— ○ ①			— ○ ①		
Clip-in chassis mount	—			—		
■ Accessories (optional) Symbol						
Motor operator	●			●		
Externally mounted	●			●		
External operating handle	●			●		
Breaker-mounted	●			●		
Door-mounted (variable depth)	●			●		
Toggle extension	—			—		
Mechanical interlock	●			●		
Slide type	●			●		
Link type	●			●		
Wire type	●			●		
Toggle holder	●			●		
Toggle lock	●			●		
Terminal cover	●			●		
For front-connected	●			●		
For rear-connected and plug-in	●			●		
Interpole barrier	● ③			● ③		
Terminal block for lead	●			●		
Door flange	●			●		
■ Standard specifications						
Overcurrent trip mechanism	Thermal-magnetic			Thermal-magnetic		
Trip button (color)	Yes (Red)			Yes (Red)		
Handle position indication (ON: Red, OFF: Green)	Yes			Yes		
Suitability for isolation	Yes			Yes		

Notes:

- : Standard. This configuration used unless otherwise specified. ○ : Optional standard. Specify when ordering.
- : "yes" or "available". — : "no" or "not available". ① : DC rating available on request. ③ : Line side interpole barriers are supplied as standard. (Front connection only) ①① : Provided with DIN rail adaptor.

Time/Current characteristic curves

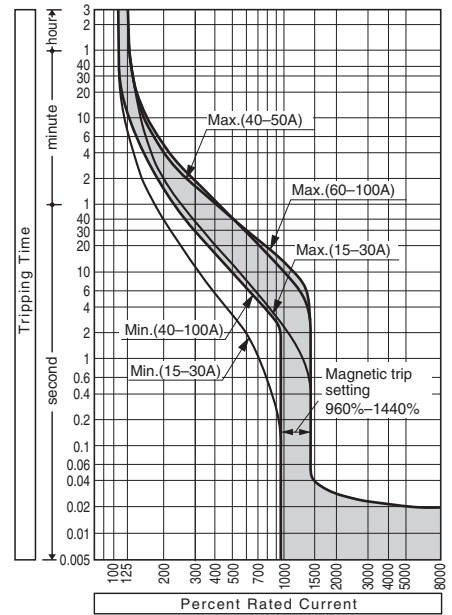

Ambient Compensating Curves

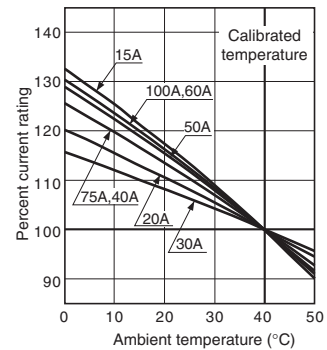

Combinations of Internally Mounted Accessories (Optional)

Poles	AX	AL	SH	UV	AX	AX	AX	AL	AL	AX	AX
	Auxiliary switch	Alarm switch	Shunt trip	Under voltage trip	AL	SH	UV	SH	UV	AL	UV
2	☐	☐	☐	☐	☐	☐	☐	☐	☐	☐	☐
3	☐	☐	☐	☐	☐	☐	☐	☐	☐	☐	☐
4	☐	☐	☐	☐	☐	☐	☐	☐	☐	☐	☐

☐ : Toggle Left pole Right pole

NOTE: 2-pole type breaker may incorporate only one combination of [AX (max.2C)], [AL], [SH], [UV], [AX (max.2C)] [AL] into the right pole.



8

Characteristics and Outline Dimensions *TemBreak2*

Molded Case Circuit Breakers

(125A Frame)

S125-NF, S125-GF

Ratings and Specifications

Type	S125-NF			S125-GF			
	2	3	4	2	3	4	
Number of poles							
■ Ratings							
Rated current, A	125			125			
Calibrated at 40°C							
■ Rated insulation voltage [U_i] V AC							
Rated insulation voltage [U _i] V AC	690			690			
■ Rated impulse withstand voltage [U_{imp}] kV							
Rated impulse withstand voltage [U _{imp}] kV	8			8			
■ Rated breaking capacity, kA							
IEC60947-2 AC	6/6			6/6			
I _{cu} /I _{cs} (sym)	500V	22/22			25/22		
	440V	25/25			50/25		
	415V	30/30			65/33		
	380V	30/30			65/33		
	240V	50/50			85/85		
	① DC	250V 25/19			40/40		
	125V 40/30			40/40			
■ Rated short time withstand current, kA							
Weight (● marked standard type) kg	0.7 1.1 1.4			0.7 1.1 1.4			
■ Connections and Mountings							
Front-connected (FC)	Terminal screws			Terminal screws			
	With extension bars			With extension bars			
Rear-connected (RC)	Bolt studs			Bolt studs			
	Flat bar studs			Flat bar studs			
Plug-in (PM)							
Draw-out type (DR)							
DIN rail mount	○ ①			○ ①			
Clip-in chassis mount							
■ Accessories (optional) Symbol							
Motor operator	●			●			
Externally mounted							
External operating handle	●			●			
Breaker-mounted	●			●			
Door-mounted (variable depth)	●			●			
Toggle extension	H A			H A			
Mechanical interlock	Slide type ●			Slide type ●			
	Link type ●			Link type ●			
	Wire type ●			Wire type ●			
Toggle holder	H H ●			H H ●			
Toggle lock	H L ●			H L ●			
Terminal cover	For front-connected ●			For front-connected ●			
	For rear-connected and plug-in ●			For rear-connected and plug-in ●			
Interpole barrier	B A ● ③			B A ● ③			
Terminal block for lead	T F ●			T F ●			
Door flange	D F ●			D F ●			
■ Standard specifications							
Overcurrent trip mechanism	Thermal-magnetic			Thermal-magnetic			
Trip button (color)	Yes (Red)			Yes (Red)			
Handle position indication (ON: Red, OFF: Green)	Yes			Yes			
Suitability for isolation	Yes			Yes			

Notes:

- : Standard. This configuration used unless otherwise specified. ○ : Optional standard. Specify when ordering.
- : "yes" or "available". — : "no" or "not available". ① : DC rating available on request. ③ : Line side interpole barriers are supplied as standard. (Front connection only) ① : Provided with DIN rail adaptor.

Time/Current characteristic curves

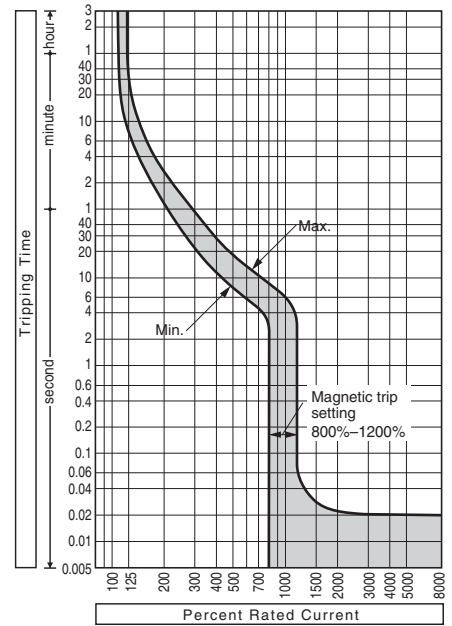

Ambient Compensating Curves

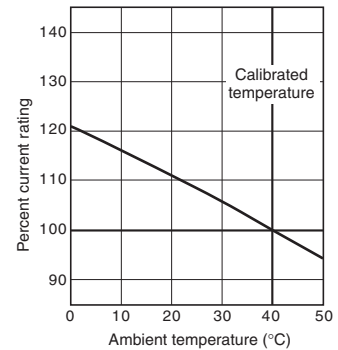

Combinations of Internally Mounted Accessories (Optional)

Poles	AX	AL	SH	UV	AX	AX	AX	AL	AL	AX	AX
	Auxiliary switch	Alarm switch	Shunt trip	Under voltage trip	AL	SH	UV	SH	UV	SH	UV
2	☐	☐	☐	☐	☐	☐	☐	☐	☐	☐	☐
3	☐	☐	☐	☐	☐	☐	☐	☐	☐	☐	☐
4	☐	☐	☐	☐	☐	☐	☐	☐	☐	☐	☐

☐ : Toggle Left pole Right pole

NOTE: 2-pole type breaker may incorporate only one combination of [AX (max.2C)], [AL], [SH], [UV], [AX (max.2C)] [AL] into the right pole.



8

Characteristics and Outline Dimensions *TemBreak2*

Molded Case Circuit Breakers

(225A Frame)

S225-NF, S225-GF

Ratings and Specifications

Type	S225-NF	S225-GF			
Number of poles	2* 3 4	2* 3 4			
■ Ratings					
Rated current, A	125 200	125			
Calibrated at 40°C	150 225	150			
	175	175			
		200			
		225			
Rated insulation voltage [U_i] V AC					
	690	690			
Rated impulse withstand voltage [U_{imp}] kV					
	8	8			
■ Rated breaking capacity, kA					
IEC60947-2 AC	690V	7.5/7.5	7.5/7.5		
<i>I_{cu}/I_{cs}(sym)</i>	500V	25/25	25/25		
	440V	25/25	50/25		
	415V	35/35	65/35		
	380V	35/35	65/35		
	240V	65/65	85/85		
① DC	250V	40/40	40/40		
	125V	40/40	40/40		
■ Rated short time withstand current, kA					
Weight (● marked standard type) kg	1.5 1.5 1.9	1.5 1.5 1.9			
■ Connections and Mountings					
Front-connected (FC)	Terminal screws	●	●		
	With extension bars	○ (BAR)	○ (BAR)		
Rear-connected (RC)	Bolt studs	—	—		
	Flat bar studs	○	○		
Plug-in (PM)		○	○		
Draw-out type (DR)		—	—		
DIN rail mount		—	—		
Clip-in chassis mount		—	—		
■ Accessories (optional) Symbol					
Motor operator	M C	●	●		
Externally mounted	External operating handle	Breaker-mounted	H B	●	
		Door-mounted (variable depth)	H P	●	
	Toggle extension		H A	—	
Externally mounted	Mechanical interlock	Slide type	M S	●	
		Link type	M L	●	
		Wire type	M W	●	
Toggle holder		H H	●		
Toggle lock		H L	●		
Terminal cover	For front-connected		C F	●	
	For rear-connected and plug-in		C R	●	
Interpole barrier		B A	● ③	● ③	
Terminal block for lead		T F	●	●	
Door flange		D F	●	●	
■ Standard specifications					
Overcurrent trip mechanism		Thermal-magnetic	Thermal-magnetic		
Trip button (color)		Yes (Red)	Yes (Red)		
Handle position indication (ON: Red, OFF: Green)		Yes	Yes		
Suitability for isolation		Yes	Yes		

Notes:

● : Standard. This configuration used unless otherwise specified. ○ : Optional standard. Specify when ordering.
 ● : "yes" or "available". — : "no" or "not available". ① : DC rating available on request. ③ : Line side interpole barriers are supplied as standard. (Front connection only)

Time/Current characteristic curves

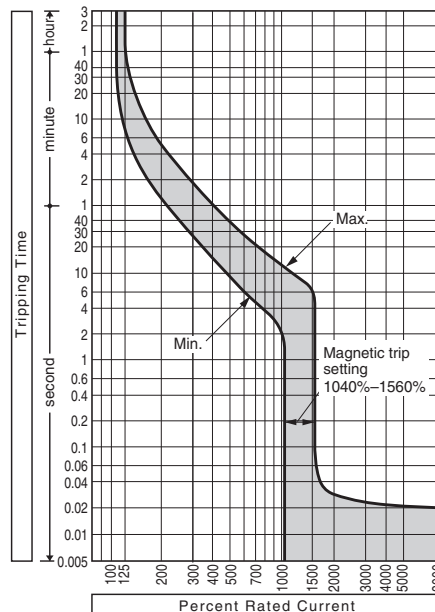

Ambient Compensating Curves

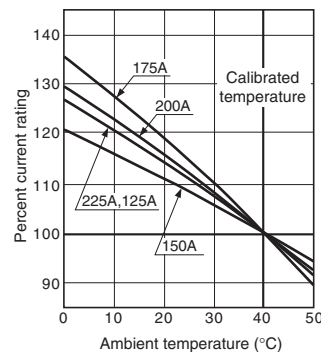

Combinations of Internally Mounted Accessories (Optional)

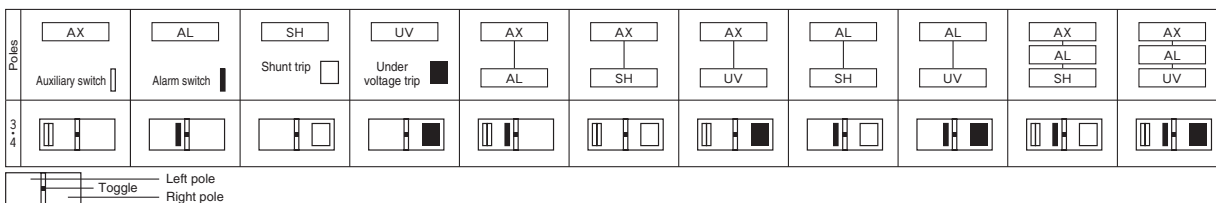



8

Characteristics and Outline Dimensions *TemBreak2*

Molded Case Circuit Breakers

(250A Frame)

S250-NF, S250-GF

Ratings and Specifications

Type	S250-NF	S250-GF		
Number of poles	2* 3 4	2* 3 4		
■ Ratings				
Rated current, A	250	250		
Calibrated at 40°C				
Rated insulation voltage [U_i] V AC				
	690	690		
Rated impulse withstand voltage [U_{imp}] kV				
	8	8		
■ Rated breaking capacity, kA				
IEC60947-2				
AC	690V	7.5/7.5	7.5/7.5	
	500V	25/25	25/25	
	440V	25/25	50/25	
	415V	35/35	65/35	
	380V	35/35	65/35	
	240V	65/65	85/85	
① DC	250V	40/40	40/40	
	125V	40/40	40/40	
■ Rated short time withstand current, kA				
Weight (● marked standard type) kg	1.5 1.5 1.9	1.5 1.5 1.9		
■ Connections and Mountings				
Front-connected (FC)	Terminal screws	●	●	
	With extension bars	○ (BAR)	○ (BAR)	
Rear-connected (RC)	Bolt studs	—	—	
	Flat bar studs	○	○	
Plug-in (PM)		○	○	
Draw-out type (DR)		—	—	
DIN rail mount		—	—	
Clip-in chassis mount		—	—	
■ Accessories (optional) Symbol				
Motor operator	M C	●	●	
External operating handle	Breaker-mounted	●	●	
	Door-mounted (variable depth)	●	●	
Toggle extension	H A	—	—	
Mechanical interlock	Slide type	●	●	
	Link type	●	●	
	Wire type	●	●	
Toggle holder	H H	●	●	
Toggle lock	H L	●	●	
Terminal cover	For front-connected	●	●	
	For rear-connected and plug-in	●	●	
Interpole barrier	B A	● ③	● ③	
Terminal block for lead	T F	●	●	
Door flange	D F	●	●	
■ Standard specifications				
Overcurrent trip mechanism	Thermal-magnetic	Thermal-magnetic		
Trip button (color)	Yes (Red)	Yes (Red)		
Handle position indication (ON: Red, OFF: Green)	Yes	Yes		
Suitability for isolation	Yes	Yes		

Notes:

● : Standard. This configuration used unless otherwise specified. ○ : Optional standard. Specify when ordering.
 ● : "yes" or "available". — : "no" or "not available". ① : DC rating available on request. ③ : Line side interpole barriers are supplied as standard. (Front connection only)

Time/Current characteristic curves

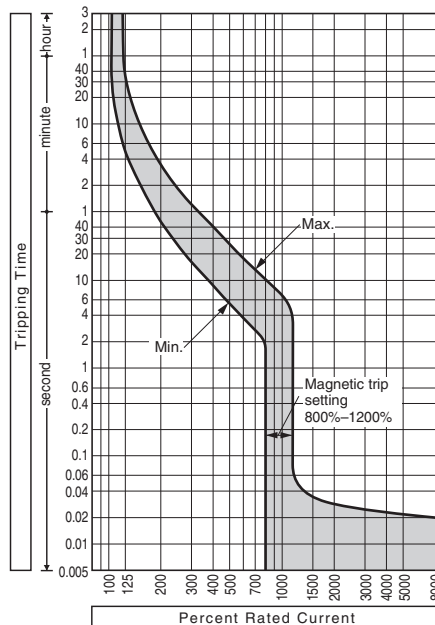

Ambient Compensating Curves

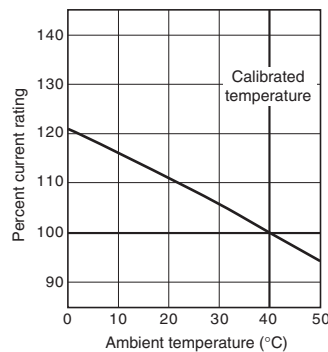

Combinations of Internally Mounted Accessories (Optional)

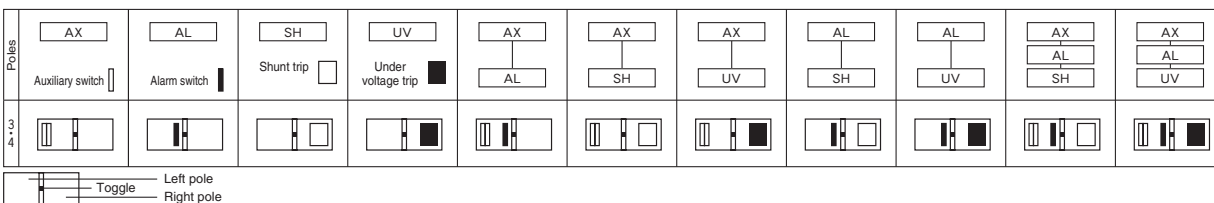



8

Characteristics and Outline Dimensions *TemBreak2*

Molded Case Circuit Breakers

(100A Frame)

H100-NF, L100-NF

Ratings and Specifications

Type	H100-NF		L100-NF	
Number of poles	3	4	3	4
■ Ratings				
Rated current, A	15	50	15	50
Calibrated at 40°C	20	60	20	60
	30	75	30	75
	40	100	40	100
Rated insulation voltage [U_i] V AC				
	690		690	
Rated impulse withstand voltage [U_{imp}] kV				
	8		8	
■ Rated breaking capacity, kA				
IEC60947-2	AC 690V		20/15	
<i>I_{cu}/I_{cs}(sym)</i>	500V		45/45	
	440V		120/80	
	415V		125/85	
	380V		125/85	
	240V		150/150	
① DC	250V		40/40	
	125V		40/40	
■ Rated short time withstand current, kA				
Weight (● marked standard type) kg	2.4	3.2	2.4	3.2
■ Connections and Mountings				
Front-connected (FC)	Terminal screws		●	
	With extension bars		○ (BAR)	
Rear-connected (RC)	Bolt studs		—	
	Flat bar studs		—	
Plug-in (PM)	○		○	
Draw-out type (DR)	—		—	
DIN rail mount	—		—	
Clip-in chassis mount	—		—	
■ Accessories (optional) Symbol				
Motor operator	M C		●	
Externally mounted	External operating handle		●	
	Breaker-mounted		●	
	Door-mounted (variable depth)		●	
	H P		●	
	Toggle extension		H A	
	—		—	
	Mechanical interlock		●	
	Slide type		M S	
	Link type		M L	
	Wire type		M W	
	—		—	
	Toggle holder		H H	
	—		—	
	Toggle lock		H L	
	—		—	
	Terminal cover		●	
	For front-connected		C F	
	For rear-connected and plug-in		C R	
	—		—	
	Interpole barrier		B A	
	—		—	
	Terminal block for lead		T F	
	—		—	
	Door flange		D F	
	—		—	
■ Standard specifications				
Overcurrent trip mechanism	Thermal-magnetic		Thermal-magnetic	
Trip button (color)	Yes (Red)		Yes (Red)	
Handle position indication (ON: Red, OFF: Green)	Yes		Yes	
Suitability for isolation	Yes		Yes	

Notes:

- : Standard. This configuration used unless otherwise specified. ○ : Optional standard. Specify when ordering.
- ▲ : Semi-standard. ● : "yes" or "available". — : "no" or "not available". ① : DC rating available on request.
- ③ : Line side interpole barriers are supplied as standard. (Front connection only)

Time/Current characteristic curves

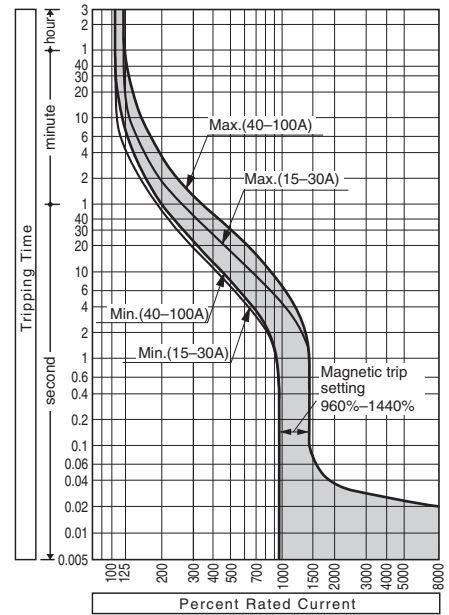

Ambient Compensating Curves

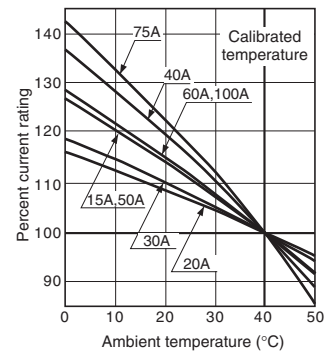

Combinations of Internally Mounted Accessories (Optional)

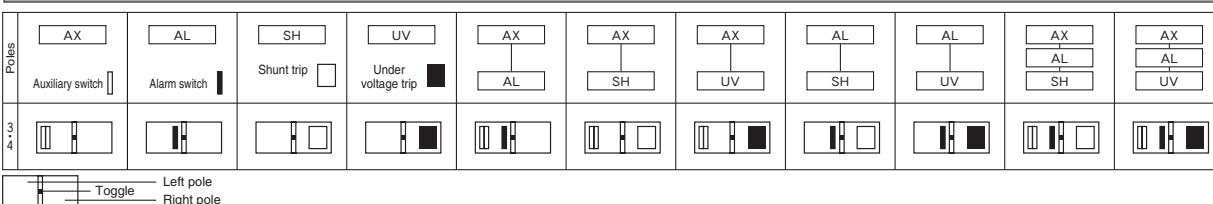

Outline dimensions (mm)

H100-NF, L100-NF

Front-connected

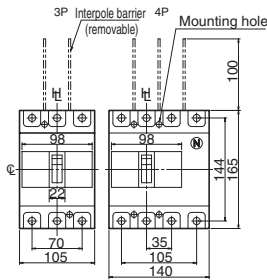

Preparation of conductor

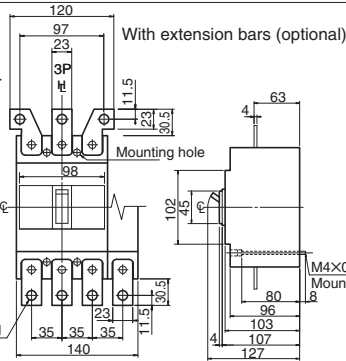
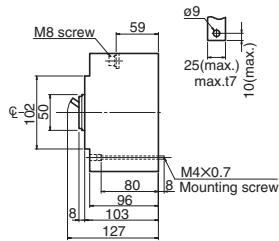

Drilling plan (front view)

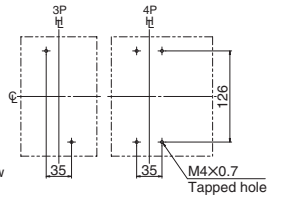

Rear-connected

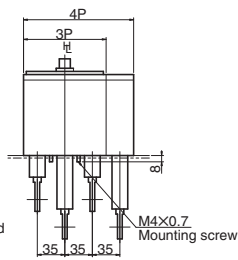
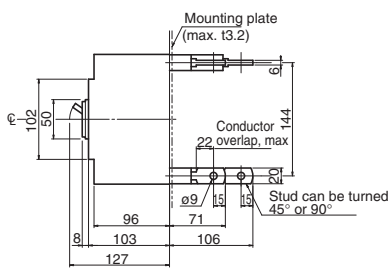

Drilling plan (front view)

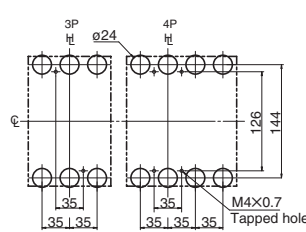

Panel cutout (front view)

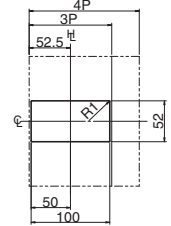

Note: Studs are factory installed in horizontal direction both on the line and load sides.

Panel cutout dimensions shown give an allowance of 1.0mm or more around the handle escutcheon.

Plug-in

Detail of connecting part

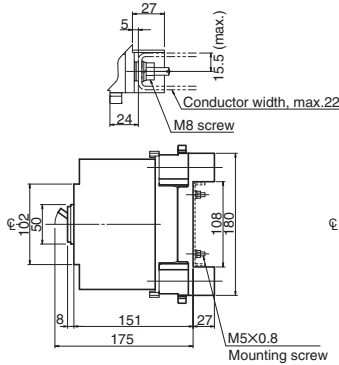

Mounting base (rear view)

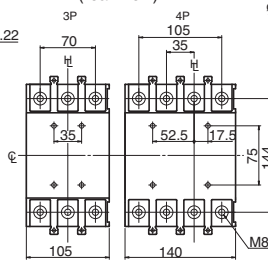

Preparation of conductor



Drilling plan (front view)

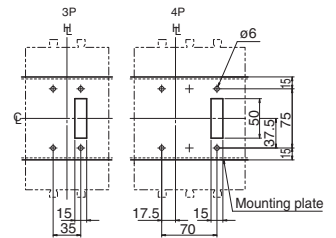



8

Characteristics and Outline Dimensions *TemBreak2*

Molded Case Circuit Breakers

(125A Frame)

H125-NF, L125-NF

Ratings and Specifications

Type	H125-NF	L125-NF		
Number of poles	3 4	3 4		
■ Ratings				
Rated current, A	125	125		
Calibrated at 40°C				
Rated insulation voltage [U_i] V AC				
	690	690		
Rated impulse withstand voltage [U_{imp}] kV				
	8	8		
■ Rated breaking capacity, kA				
IEC60947-2 AC	690V 20/15	25/20		
<i>I_{cu}/I_{cs}(sym)</i>	500V 45/45	65/65		
	440V 120/80	180/135		
	415V 125/85	200/150		
	380V 125/85	200/150		
	240V 150/150	200/150		
① DC	250V 40/40	40/40		
	125V 40/40	40/40		
■ Rated short time withstand current, kA				
Weight (● marked standard type) kg	2.4 3.2	2.4 3.2		
■ Connections and Mountings				
Front-connected (FC)	Terminal screws	●	●	
	With extension bars	○ (BAR)	○ (BAR)	
Rear-connected (RC)	Bolt studs	—	—	
	Flat bar studs	○	○	
Plug-in (PM)	○	○		
Draw-out type (DR)	—	—		
DIN rail mount	—	—		
Clip-in chassis mount	—	—		
■ Accessories (optional) Symbol				
Motor operator	M C	●	●	
Externally mounted				
External operating handle	Breaker-mounted H B	●	●	
	Door-mounted (variable depth) H P	●	●	
	Toggle extension H A	—	—	
Mechanical interlock	Slide type M S	●	●	
	Link type M L	●	●	
	Wire type M W	●	●	
Toggle holder	H H	●	●	
Toggle lock	H L	●	●	
Terminal cover	For front-connected C F	●	●	
	For rear-connected and plug-in C R	●	●	
Interpole barrier	B A	● ③	● ③	
Terminal block for lead	T F	●	●	
Door flange	D F	●	●	
■ Standard specifications				
Overcurrent trip mechanism	Thermal-magnetic	Thermal-magnetic		
Trip button (color)	Yes (Red)	Yes (Red)		
Handle position indication (ON: Red, OFF: Green)	Yes	Yes		
Suitability for isolation	Yes	Yes		

Notes:
 ● : Standard. This configuration used unless otherwise specified. ○ : Optional standard. Specify when ordering.
 ▲ : Semi-standard. ● : "yes" or "available". — : "no" or "not available". ① : DC rating available on request.
 ③ : Line side interpole barriers are supplied as standard. (Front connection only)

Time/Current characteristic curves

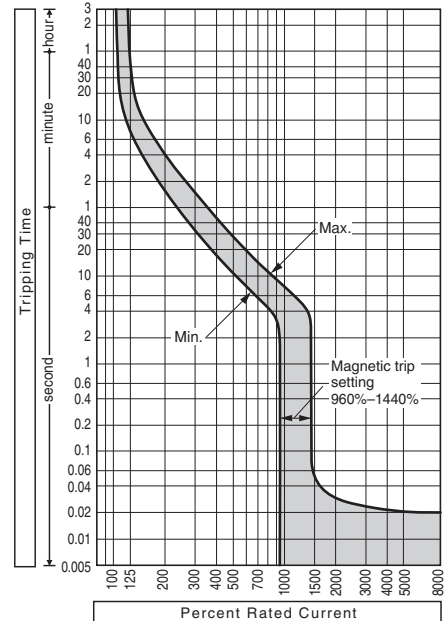

Ambient Compensating Curves

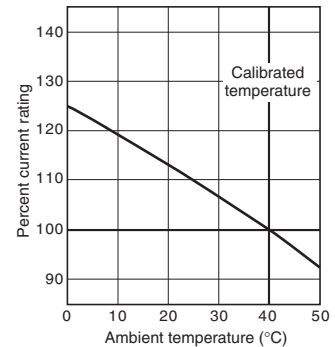

Combinations of Internally Mounted Accessories (Optional)

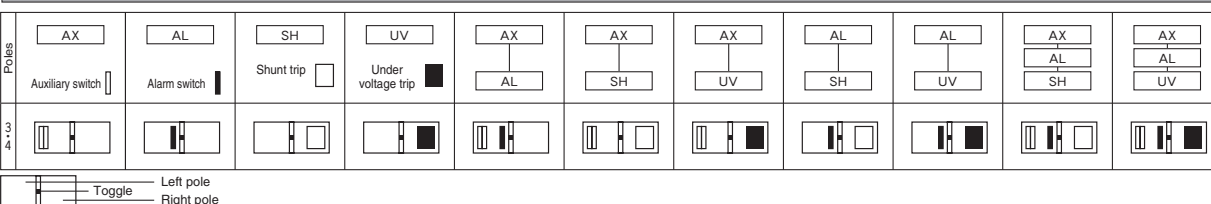

Outline dimensions (mm)

H125-NF, L125-NF

Front-connected

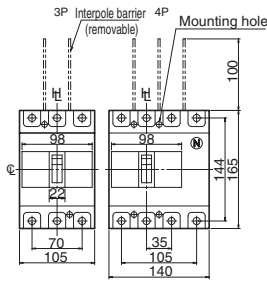

Preparation of conductor

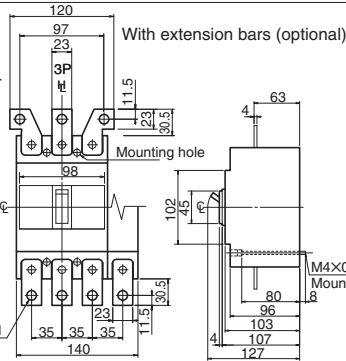
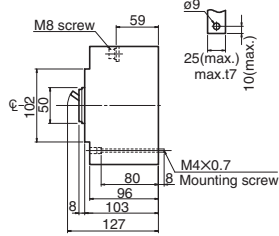

Drilling plan (front view)

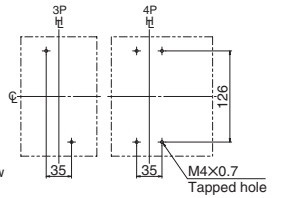

Rear-connected

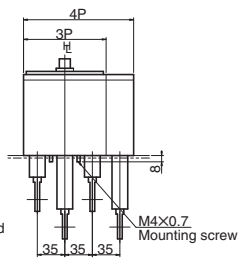
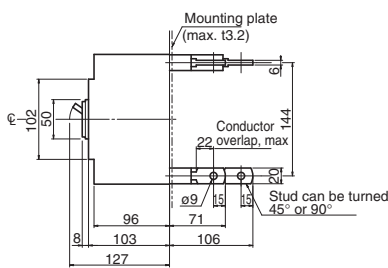

Drilling plan (front view)

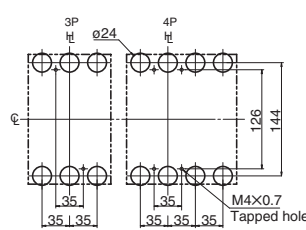

Panel cutout (front view)

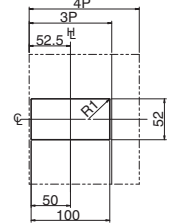

Panel cutout dimensions shown give an allowance of 1.0mm or more around the handle escutcheon.

Note: Studs are factory installed in horizontal direction both on the line and load sides.

Plug-in

Detail of connecting part

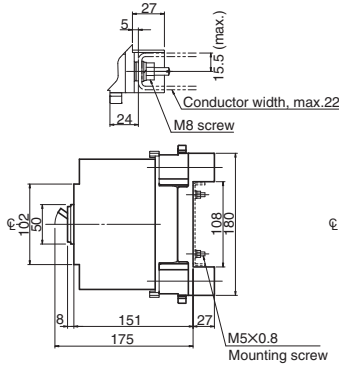

Mounting base (rear view)

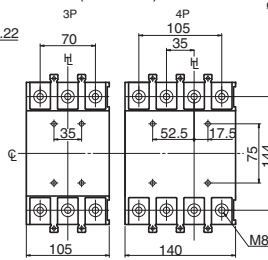

Preparation of conductor



Drilling plan (front view)

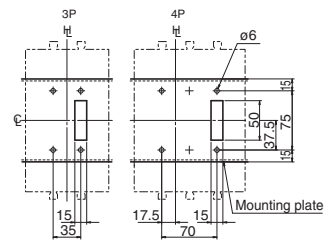



8

Characteristics and Outline Dimensions *TemBreak2*

Molded Case Circuit Breakers

(225A Frame)

H225-NF, L225-NF

Ratings and Specifications

Type	H225-NF		L225-NF	
Number of poles	3	4	3	4
■ Ratings				
Rated current, A	125	150	175	200
Calibrated at 40°C	150	175	200	225
■ Rated breaking capacity, kA				
IEC60947-2	20/15	25/20	45/45	65/65
$I_{cu}/I_{cs}(sym)$	AC 690V	45/45	120/80	180/135
	500V	125/85	200/150	200/150
	440V	125/85	200/150	200/150
	415V	150/150	40/40	40/40
	380V	40/40	40/40	40/40
① DC 250V	—	—	—	—
125V	—	—	—	—
■ Rated short time withstand current, kA				
Weight (● marked standard type) kg	2.4	3.2	2.4	3.2
■ Connections and Mountings				
Front-connected (FC)	Terminal screws	○	Terminal screws	○
	With extension bars	○ (BAR)	With extension bars	○ (BAR)
Rear-connected (RC)	Bolt studs	—	Bolt studs	—
	Flat bar studs	○	Flat bar studs	○
Plug-in (PM)	○	○	○	○
Draw-out type (DR)	—	—	—	—
DIN rail mount	—	—	—	—
Clip-in chassis mount	—	—	—	—
■ Accessories (optional) Symbol				
Motor operator	M C	●	M C	●
Externally mounted	Breaker-mounted handle	H B	Breaker-mounted handle	H B
	Door-mounted (variable depth)	H P	Door-mounted (variable depth)	H P
	Toggle extension	H A	Toggle extension	H A
	Mechanical interlock	M S	Mechanical interlock	M S
	Slide type	●	Slide type	●
	Link type	●	Link type	●
	Wire type	MW	Wire type	MW
	Toggle holder	H H	Toggle holder	H H
	Toggle lock	H L	Toggle lock	H L
	Terminal cover For front-connected	C F	Terminal cover For front-connected	C F
	For rear-connected and plug-in	C R	For rear-connected and plug-in	C R
	Interpole barrier	B A	Interpole barrier	B A
	Terminal block for lead	T F	Terminal block for lead	T F
	Door flange	D F	Door flange	D F
■ Standard specifications				
Overcurrent trip mechanism	Thermal-magnetic	Thermal-magnetic	Thermal-magnetic	Thermal-magnetic
Trip button (color)	Yes (Red)	Yes (Red)	Yes (Red)	Yes (Red)
Handle position indication (ON: Red, OFF: Green)	Yes	Yes	Yes	Yes
Suitability for isolation	Yes	Yes	Yes	Yes

Notes:
 ● : Standard. This configuration used unless otherwise specified. ○ : Optional standard. Specify when ordering.
 ▲ : Semi-standard. ● : "yes" or "available". — : "no" or "not available". ① : DC rating available on request.
 ③ : Line side interpole barriers are supplied as standard. (Front connection only)

Time/Current characteristic curves

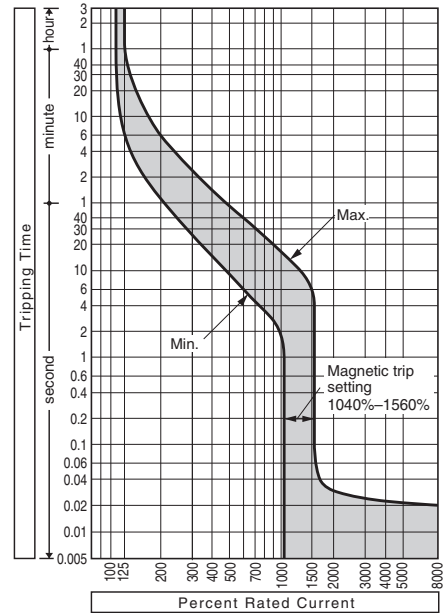

Ambient Compensating Curves

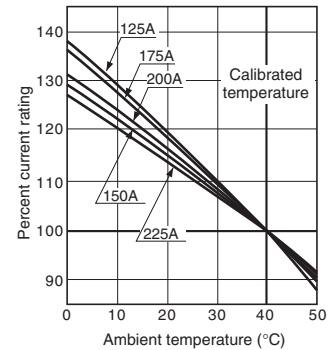

Combinations of Internally Mounted Accessories (Optional)

Accessories	AX	AL	SH	UV	AX	AX	AX	AL	AL	AX	AX
AX	AX	AL	SH	UV	AX	AX	AX	AL	AL	AX	AX
AL	AL	SH	UV	SH	SH	UV	SH	UV	UV	SH	UV
SH	SH	UV	SH	SH	SH	UV	SH	UV	SH	UV	UV
UV	UV	SH	UV	SH	SH	UV	SH	UV	SH	UV	UV
AX	AX	SH	UV	SH	SH	UV	SH	UV	SH	UV	UV
AL	AL	SH	UV	SH	SH	UV	SH	UV	SH	UV	UV
AX	AX	SH	UV	SH	SH	UV	SH	UV	SH	UV	UV
AL	AL	SH	UV	SH	SH	UV	SH	UV	SH	UV	UV
SH	SH	UV	SH	SH	SH	UV	SH	UV	SH	UV	UV
UV	UV	SH	UV	SH	SH	UV	SH	UV	SH	UV	UV
AX	AX	SH	UV	SH	SH	UV	SH	UV	SH	UV	UV
AL	AL	SH	UV	SH	SH	UV	SH	UV	SH	UV	UV
SH	SH	UV	SH	SH	SH	UV	SH	UV	SH	UV	UV
UV	UV	SH	UV	SH	SH	UV	SH	UV	SH	UV	UV

Outline dimensions (mm)

H225-NF, L225-NF

Front-connected

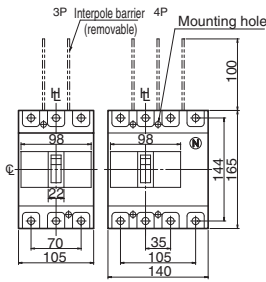

Preparation of conductor

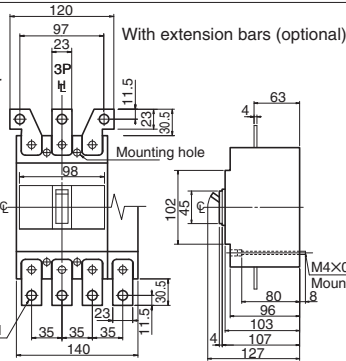
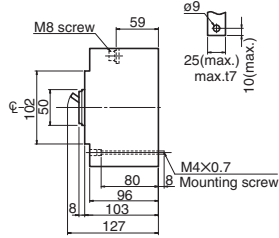

Drilling plan (front view)

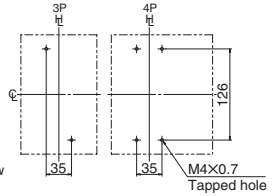

Rear-connected

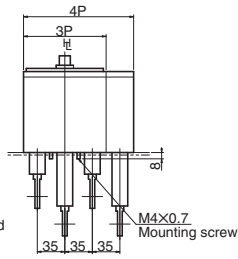
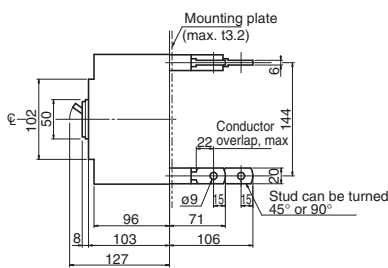

Drilling plan (front view)

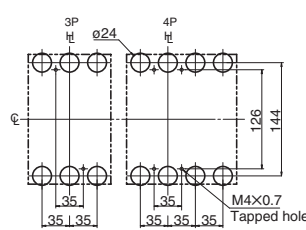

Panel cutout (front view)

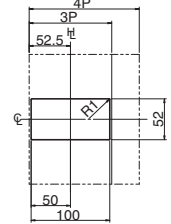

Note: Studs are factory installed in horizontal direction both on the line and load sides.

Panel cutout dimensions shown give an allowance of 1.0mm or more around the handle escutcheon.

Plug-in

Detail of connecting part

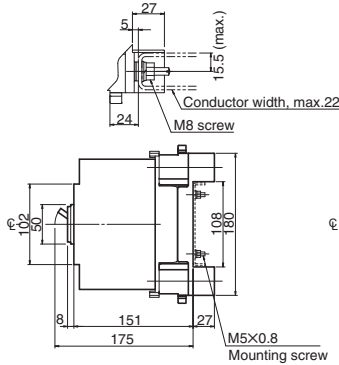

Mounting base (rear view)

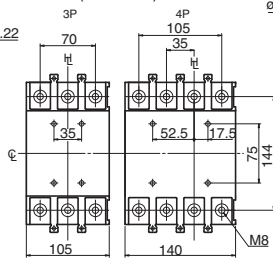

Preparation of conductor



Drilling plan (front view)

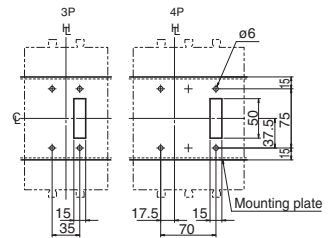



8

Characteristics and Outline Dimensions *TemBreak2*

Molded Case Circuit Breakers

(250A Frame)

H250-NF, L250-NF

Ratings and Specifications

Type	H250-NF	L250-NF		
Number of poles	3 4	3 4		
■ Ratings				
Rated current, A	250	250		
Calibrated at 40°C				
■ Rated insulation voltage [U_i] V AC				
Rated insulation voltage [U _i] V AC	690	690		
■ Rated impulse withstand voltage [U_{imp}] kV				
Rated impulse withstand voltage [U _{imp}] kV	8	8		
■ Rated breaking capacity, kA				
IEC60947-2 AC	20/15	25/20		
<i>I_{cu}/I_{cs}(sym)</i>	500V	45/45	65/65	
	440V	120/80	180/135	
	415V	125/85	200/150	
	380V	125/85	200/150	
	240V	150/150	200/150	
① DC	40/40	40/40		
	40/40	40/40		
	—	—		
■ Rated short time withstand current, kA				
Weight (● marked standard type) kg	2.4 3.2	2.4 3.2		
■ Connections and Mountings				
Front-connected (FC)	Terminal screws	●	●	
	With extension bars	○ (BAR)	○ (BAR)	
Rear-connected (RC)	Bolt studs	—	—	
	Flat bar studs	○	○	
Plug-in (PM)	—	—	—	
Draw-out type (DR)	—	—	—	
DIN rail mount	—	—	—	
Clip-in chassis mount	—	—	—	
■ Accessories (optional) Symbol				
Motor operator	M C	●	●	
Externally mounted				
External operating handle	Breaker-mounted	H B	●	
	Door-mounted (variable depth)	H P	●	
Toggle extension	H A	—	—	
Mechanical interlock	Slide type	M S	●	
	Link type	M L	●	
	Wire type	M W	●	
Toggle holder	H H	●	●	
Toggle lock	H L	●	●	
Terminal cover	For front-connected	C F	●	
	For rear-connected and plug-in	C R	●	
Interpole barrier	B A	● ③	● ③	
Terminal block for lead	T F	●	●	
Door flange	D F	●	●	
■ Standard specifications				
Overcurrent trip mechanism	Thermal-magnetic	Thermal-magnetic		
Trip button (color)	Yes (Red)	Yes (Red)		
Handle position indication (ON: Red, OFF: Green)	Yes	Yes		
Suitability for isolation	Yes	Yes		

Notes:

- : Standard. This configuration used unless otherwise specified. ○ : Optional standard. Specify when ordering.
- ▲ : Semi-standard. ● : "yes" or "available". — : "no" or "not available". ① : DC rating available on request.
- ③ : Line side interpole barriers are supplied as standard. (Front connection only)

Time/Current characteristic curves

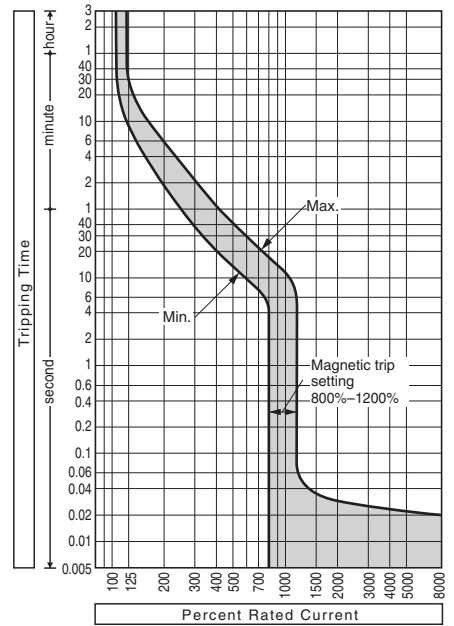

Ambient Compensating Curves

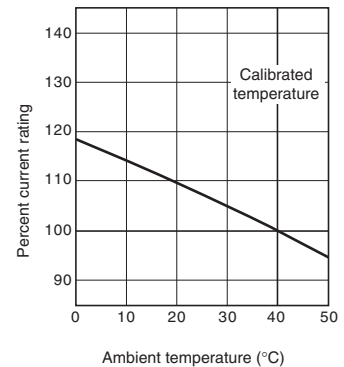

Combinations of Internally Mounted Accessories (Optional)

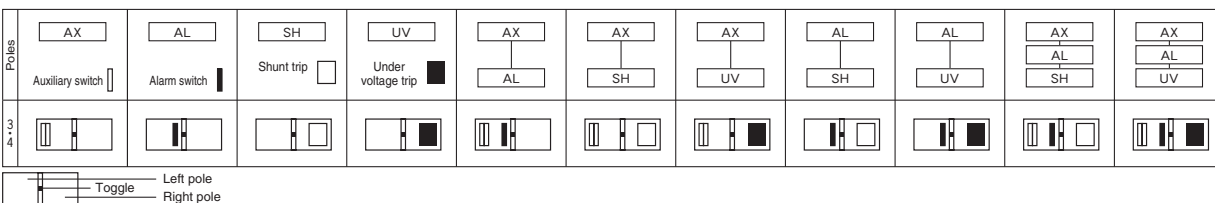

Outline dimensions (mm)

H250-NF, L250-NF

Front-connected

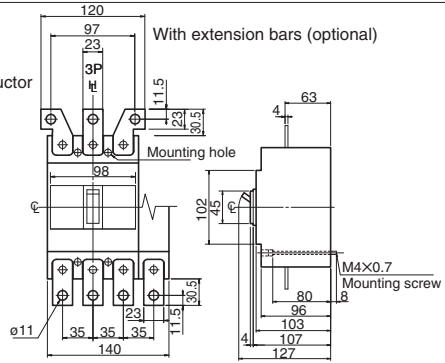
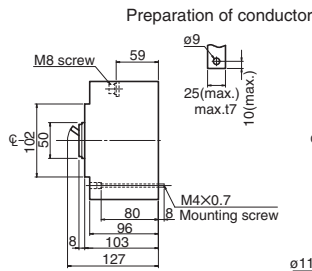
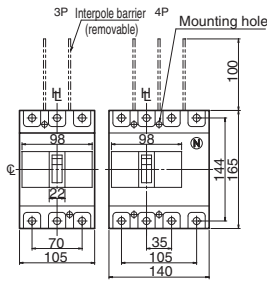

Drilling plan (front view)

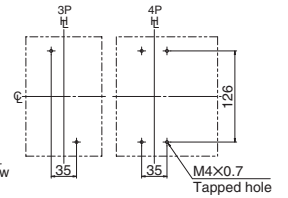

Rear-connected

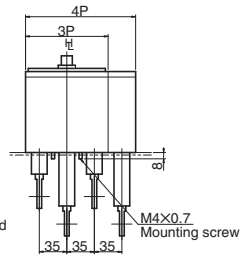
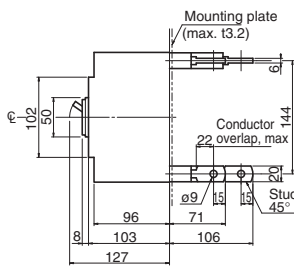

Drilling plan (front view)

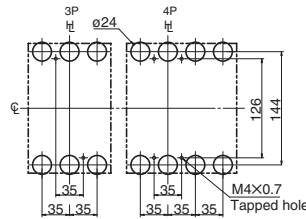

Panel cutout (front view)

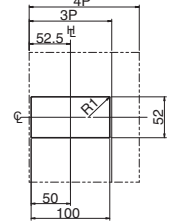

Note: Studs are factory installed in horizontal direction both on the line and load sides.

Panel cutout dimensions shown give an allowance of 1.0mm or more around the handle escutcheon.



8

Characteristics and Outline Dimensions *TemBreak2*

Molded Case Circuit Breakers

(400A Frame)

E400-NF

Ratings and Specifications

Type	E400-NF			
Number of poles	3			
■ Ratings				
Rated current, A	250			
Calibrated at 40°C	300			
	350			
	400			
Rated insulation voltage [U_i] V AC				
	690			
Rated impulse withstand voltage [U_{imp}] kV				
	8			
■ Rated breaking capacity, kA				
IEC60947-2	AC	690V		
<i>I_{cu}/I_{cs}(sym)</i>		500V	15/15	
		440V	22/22	
		415V	25/25	
		380V	25/25	
		240V	35/35	
		① DC	250V	25/19
		125V	40/30	
■ Rated short time withstand current, kA				
Weight (● marked standard type) kg		4.2		
■ Connections and Mountings				
Front-connected (FC)	Terminal screws	●		
	With extension bars	○ (BAR)		
Rear-connected (RC)	Bolt studs	—		
	Flat bar studs	○		
Plug-in (PM)		—		
Draw-out type (DR)		—		
DIN rail mount		—		
Clip-in chassis mount		—		
■ Accessories (optional) Symbol				
Motor operator		M C	●	
Externally mounted				
External operating handle	Breaker-mounted	H B	●	
	Door-mounted (variable depth)	H P	●	
Toggle extension		H A	—	
Mechanical interlock	Slide type	M S	●	
	Link type	M L	●	
	Wire type	M W	●	
Toggle holder		H H	●	
Toggle lock		H L	●	
Terminal cover	For front-connected	C F	●	
	For rear-connected and plug-in	C R	●	
Interpole barrier		B A	● ③	
Terminal block for lead		T F	●	
Door flange		D F	●	
■ Standard specifications				
Overcurrent trip mechanism		Thermal-magnetic		
Trip button (color)		Yes (Red)		
Handle position indication (ON: Red, OFF: Green)		Yes		
Suitability for isolation		Yes		

Notes:

- : Standard. This configuration used unless otherwise specified. ○ : Optional standard. Specify when ordering.
- ▲ : Semi-standard. ● : "yes" or "available". — : "no" or "not available". ① : DC rating available on request.
- ③ : Line side interpole barriers are supplied as standard. (Front connection only)

Time/Current characteristic curves

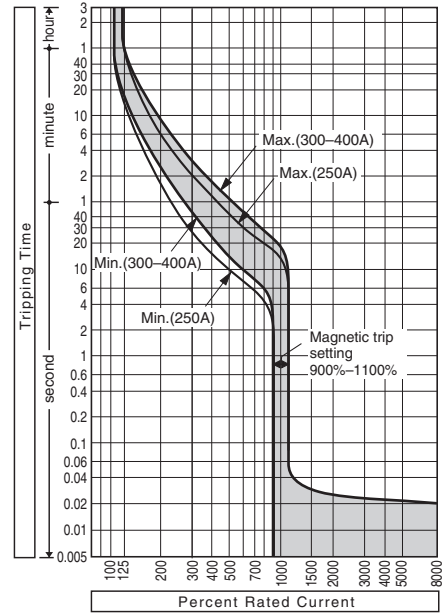

Ambient Compensating Curves

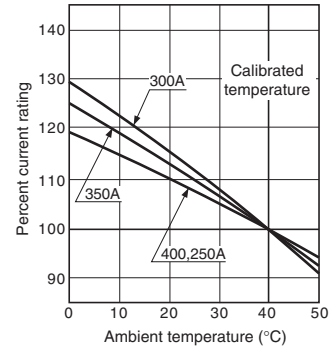

Magnetic trip pickup current

Rated current (A)	Magnetic trip pickup current (A)
250	2500
300	3000
350	3500
400	4000

Notes:

- 1. Setting tolerance: ±10%.

Combinations of Internally Mounted Accessories (Optional)

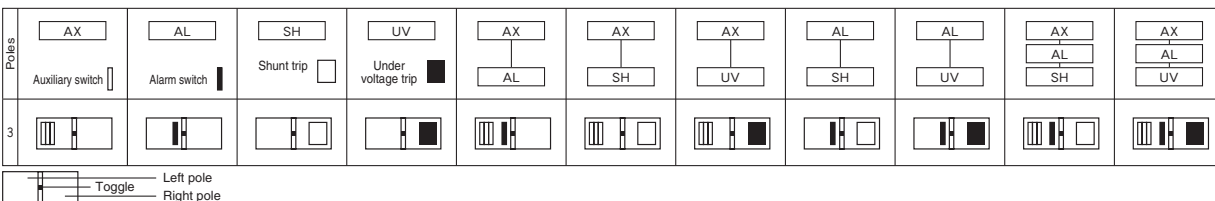

Outline dimensions (mm)

E400-NF

Front-connected

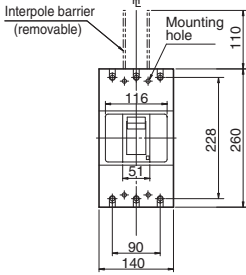

Preparation of conductor

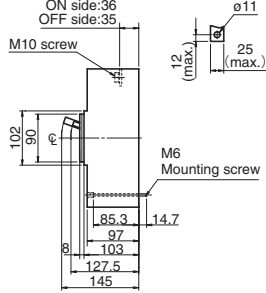

With extension bars (optional)

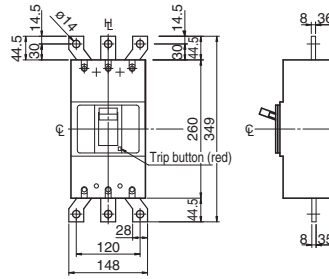

Drilling plan (front view)

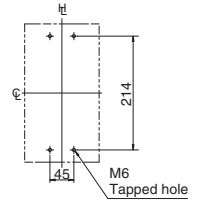

Rear-connected

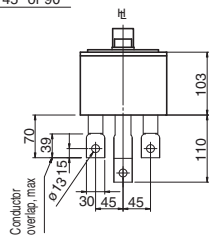
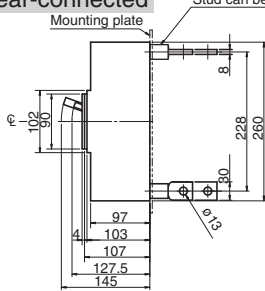

Drilling plan (front view)

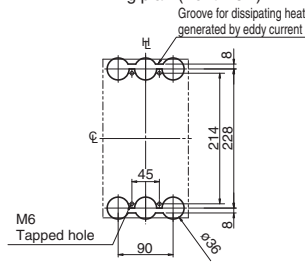

Panel cutout (front view)

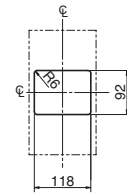

Note: Studs are factory installed in horizontal direction both on the line and load sides.

Panel cutout dimensions shown give an allowance of 1.0mm around the handle escutcheon.



8 Characteristics and Outline Dimensions *TemBreak2*

Molded Case Circuit Breakers (400A Frame)

S400-CF, S400-NF, S400-GF, S400-PF

Ratings and Specifications

Type	S400-CF		S400-NF		S400-GF		S400-PF	
	3	4	3	4	3	4	3	4
Number of poles	3 4		3 4		3 4		3 4	
■ Ratings								
Rated current, A	125	250	125	250	125	250	250	
Calibrated at 40°C	150	300	150	300	150	300	300	
	175	350	175	350	175	350	350	
	200	400	200	400	200	400	400	
	225		225		225			
Rated insulation voltage [U_i] V AC								
	690		690		690		690	
Rated impulse withstand voltage [U_{imp}] kV								
	8		8		8		8	
■ Rated breaking capacity, kA								
IEC60947-2	AC 690V		20/15		20/15		20/15	
I _{cu} /I _{cs} (sym)	500V		30/30		30/30		30/30	
	440V		45/45		65/50		80/80	
	415V		36/36		50/50		70/50	
	380V		36/36		50/50		70/50	
	240V		50/50		85/85		100/85	
① DC	250V		40/40		40/40		40/40	
	125V		40/40		40/40		40/40	
■ Rated short time withstand current, kA								
Weight (● marked standard type) kg	4.2	5.6	4.2	5.6	4.2	5.6	4.2	5.6
■ Connections and Mountings								
Front-connected (FC)	Terminal screws		●		●		●	
	With extension bars		○ (BAR)		○ (BAR)		○ (BAR)	
Rear-connected (RC)	Bolt studs		—		—		—	
	Flat bar studs		—		—		—	
Plug-in (PM)	○		○		○		○	
Draw-out type (DR)	▲		▲		▲		▲	
DIN rail mount	—		—		—		—	
Clip-in chassis mount	—		—		—		—	
■ Accessories (optional) Symbol								
Motor operator	M C		●		●		●	
External operating handle	Breaker-mounted H B		●		●		●	
	Door-mounted (variable depth) H P		●		●		●	
Toggle extension	H A		—		—		—	
Mechanical interlock③	Slide type M S		●		●		●	
	Link type M L		●		●		●	
	Wire type M W		●		●		●	
Toggle holder	H H		●		●		●	
	H L		●		●		●	
Terminal cover	For front-connected C F		●		●		●	
	For rear-connected and plug-in C R		●		●		●	
Interpole barrier	B A		● ③		● ③		● ③	
	Terminal block for lead T F		●		●		●	
Door flange	D F		●		●		●	
■ Standard specifications								
Overcurrent trip mechanism	Thermal-magnetic		Thermal-magnetic		Thermal-magnetic		Thermal-magnetic	
Trip button (color)	Yes (Red)		Yes (Red)		Yes (Red)		Yes (Red)	
Handle position indication (ON: Red, OFF: Green)	Yes		Yes		Yes		Yes	
Suitability for isolation	Yes		Yes		Yes		Yes	

Notes:
 ● : Standard. This configuration used unless otherwise specified. ○ : Optional standard. Specify when ordering.
 ▲ : Semi-standard. ● : "yes" or "available". — : "no" or "not available". ① : DC rating available on request.
 ③ : Line side interpole barriers are supplied as standard. (Front connection only)
 ⑨ : The mechanical interlock is not applicable to the draw-out type (DR).

Time/Current characteristic curves

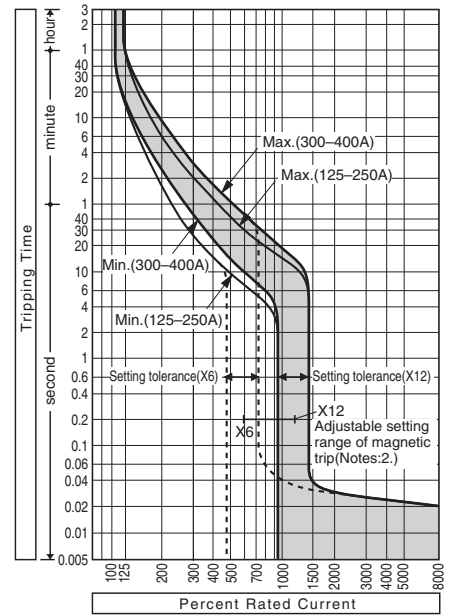

Ambient Compensating Curves

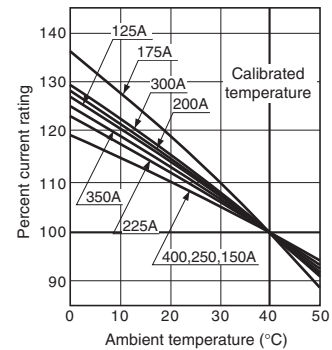

Magnetic trip pickup current

Rated current (A)	Magnetic trip pickup current Adjustable range (A)					
	I _n × 11	10	9	8	7	6
125	1500	1375	1250	1125	1000	875
150	1800	1650	1500	1350	1200	1050
175	2100	1925	1750	1575	1400	1225
200	2400	2200	2000	1800	1600	1400
225	2700	2475	2250	2025	1800	1575
250	3000	2750	2500	2250	2000	1750
300	3600	3300	3000	2700	2400	2100
350	4200	3850	3500	3150	2800	2450
400	4800	4400	4000	3600	3200	2800

Notes:
 1. Setting tolerance: ±20%.
 2. The protection characteristic curves assume that the magnetic trip current is adjustable.
 3. Unless otherwise stated when ordering, the selector dial is factory set to position "12".
 4. The trip pickup current of DC models is not adjustable; the dial position corresponding to the trip pickup current is marked with a white point.

Combinations of Internally Mounted Accessories (Optional)

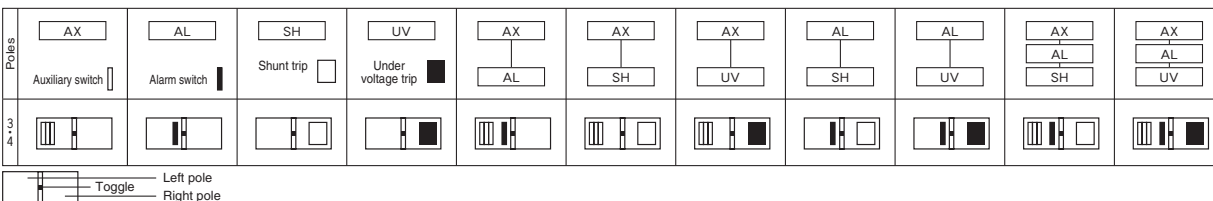

Outline dimensions (mm)

S400-CF, S400-NF, S400-GF, S400-PF

Front-connected

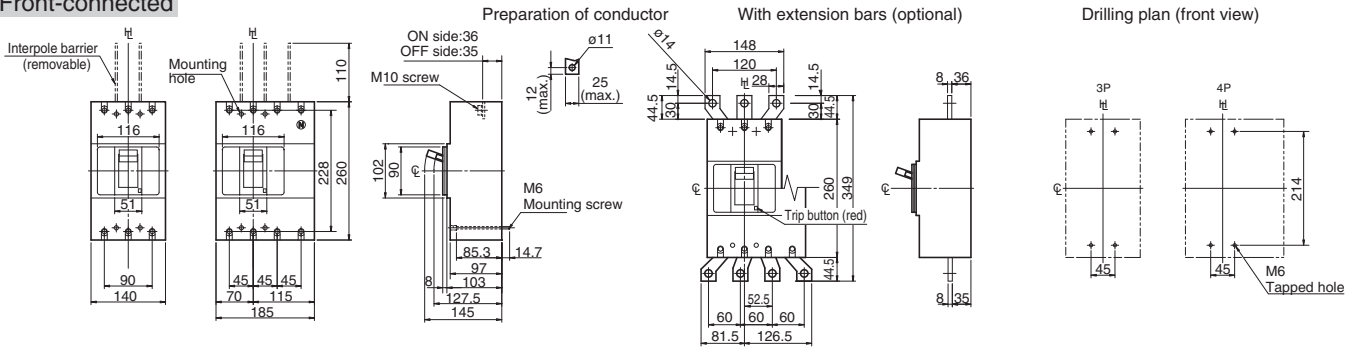

Rear-connected

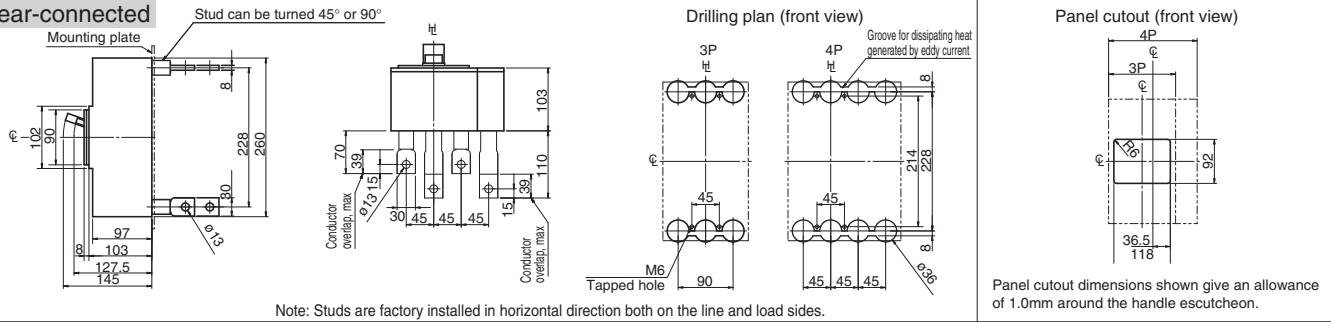

Note: Studs are factory installed in horizontal direction both on the line and load sides.

Panel cutout dimensions shown give an allowance of 1.0mm around the handle escutcheon.

Plug-in

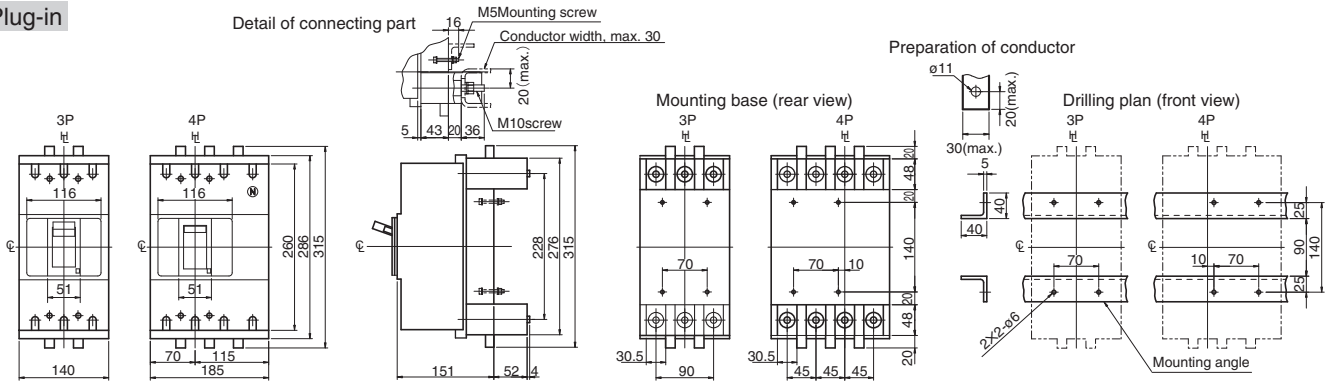



8 Characteristics and Outline Dimensions *TemBreak2*

Molded Case Circuit Breakers (800A Frame)

S800-CF, S800-NF, S800-RF

Ratings and Specifications

Type	S800-CF		S800-NF		S800-RF	
	3	4	3	4	3	4
Number of poles	3 4		3 4		3 4	
■ Ratings						
Rated current, A	500 600 630 700 800		500 600 630 700 800		500 600 630 700 800	
Calibrated at 40°C						
■ Rated breaking capacity, kA						
IEC60947-2 AC	690V 10/10 15/15 30/30 45/45 65/50 70/50		20/20 30/30 45/45 50/50 70/50		25/20 45/34 65/50 70/50	
$I_{cu}/I_{cs}(sym)$	500V 440V 415V 380V 240V ① DC 250V 125V		50/50 50/50 50/50		50/50 50/50 50/50	
■ Rated short time withstand current, kA						
Weight (● marked standard type) kg	8.5 11.5		8.5 11.5		8.5 11.5	
■ Connections and Mountings						
Front-connected (FC)	Terminal screws With extension bars		Terminal screws		Terminal screws	
Rear-connected (RC)	Bolt studs Flat bar studs		Bolt studs		Bolt studs	
Plug-in (PM)	○		○		○	
Draw-out type (DR)	▲		▲		▲	
DIN rail mount	—		—		—	
Clip-in chassis mount	—		—		—	
■ Accessories (optional) Symbol						
Motor operator	●		●		●	
Externally mounted	●		●		●	
External operating handle	●		●		●	
Breaker-mounted handle	●		●		●	
Door-mounted (variable depth)	●		●		●	
Toggle extension	●		●		●	
Mechanical interlock③	●		●		●	
Slide type	●		●		●	
Link type	●		●		●	
Wire type	●		●		●	
Toggle holder	●		●		●	
Toggle lock	●		●		●	
Terminal cover	●		●		●	
For front-connected	●		●		●	
For rear-connected and plug-in	●		●		●	
Interpole barrier	● ③		● ③		● ③	
Terminal block for lead	●		●		●	
Door flange	●		●		●	
■ Standard specifications						
Overcurrent trip mechanism	Thermal-magnetic(adjustable)		Thermal-magnetic(adjustable)		Thermal-magnetic(adjustable)	
Trip button (color)	Yes (Red)		Yes (Red)		Yes (Red)	
Handle position indication (ON: Red, OFF: Green)	Yes		Yes		Yes	
Suitability for isolation	Yes		Yes		Yes	

Notes:
 ● : Standard. This configuration used unless otherwise specified. ○ : Optional standard. Specify when ordering.
 ▲ : Semi-standard. ● : "yes" or "available". — : "no" or "not available". ① : DC rating available on request.
 ③ : Line side interpole barriers are supplied as standard. (Front connection only) ④ : The mechanical interlock is not applicable to the draw-out type (DR).

Time/Current characteristic curves

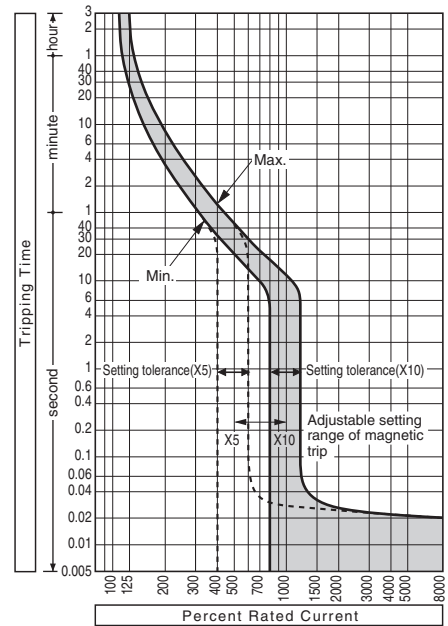

Ambient Compensating Curves

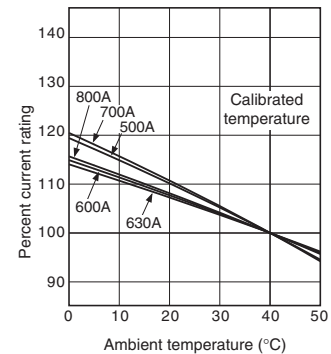

Magnetic trip pickup current

Rated current (A)	Magnetic trip pickup current Adjustable range (A)				
	$I_n \times 10$	9	8	7	6 5
500	5000	4500	4000	3500	3000 2500
600	6000	5400	4800	4200	3600 3000
630	6300	5670	5040	4410	3780 3150
700	7000	6300	5600	4900	4200 3500
800	8000	7200	6400	5600	4800 4000

Notes:
 1. Setting tolerance: $\pm 20\%$.
 2. Unless otherwise stated when ordering, the selector dial is factory set to position "10".
 3. The trip pickup current of DC models is not adjustable; the dial position corresponding to the trip pickup current is marked with a white point.

Combinations of Internally Mounted Accessories (Optional)

PolBS	AX	AL	SH	UV	AX	AX	AX	AL	AL	AX	AX
Auxiliary switch	□	□	□	■	□	□	□	□	□	□	□
Alarm switch	□	□	□	■	□	□	□	□	□	□	□
Shunt trip	□	□	□	■	□	□	□	□	□	□	□
Under voltage trip	□	□	□	■	□	□	□	□	□	□	□
Toggle	□	□	□	■	□	□	□	□	□	□	□
Left pole	□	□	□	■	□	□	□	□	□	□	□
Right pole	□	□	□	■	□	□	□	□	□	□	□

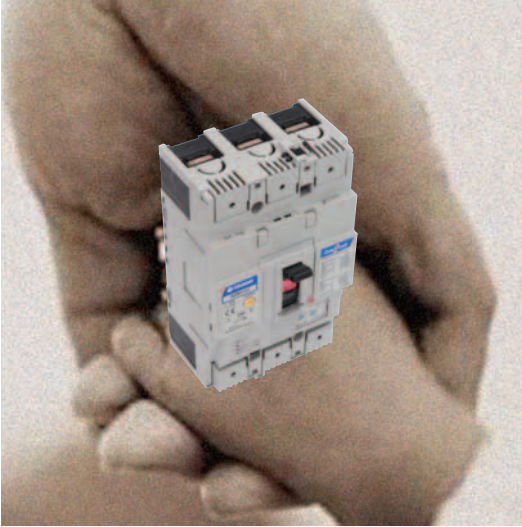

TERASAKI ELECTRIC CO., LTD.

Head Office: 7-2-10 Hannancho, Abenoku
Osaka, Japan
Circuit Breaker Division: 7-2-10 Kamihigashi, Hiranoku Osaka, Japan
Telephone: 81-6-6791-9323
Fax: 81-6-6791-9274
Email: int-sales@terasaki.co.jp
<http://www.terasaki.co.jp/>

TERASAKI ELECTRIC (M) SDN, BHD.

Lot 3, Jalan 16/13D, 40000 Shah Alam, Selangor Darul
Ehsan, Malaysia

Telephone: 60-3-5549-3820
Fax: 60-3-5549-3960
Email: terasaki@terasaki.com.my

TERASAKI ELECTRIC TRADING & SERVICES (M) SDN. BHD.

No. 20 & 22, Jalan Rajawali 2, Bandar Puchong Jaya,
Jalan Puchong, 47100 Selangor Darul Ehsan, Malaysia

Telephone: 60-3-8070-2486, 60-3-8075-1542
Fax: 60-3-8070-2481
Email: sales@terasaki.com.my

TERASAKI DO BRASIL LTDA.

Rua Cordovil, 259-Parada De Lucas, 21250-450
Rio De Janeiro-R.J., Brazil

Telephone: 55-21-3301-9898
Fax: 55-21-3301-9861
Email: terasaki@terasaki.com.br
<http://www.terasaki.com.br>

TERASAKI ELECTRIC (CHINA) LTD.

72 Pacific Industrial Park, Xin Tang Zengcheng,
Guangzhou 511340, China

Telephone: 86-20-8270-8556
Fax: 86-20-8270-8586
Email: terasaki@public.guangzhou.gd.cn

TERASAKI ELECTRIC GROUP SHANGHAI REPRESENTATIVE OFFICE

Room No. 1405-6, Tomson Commercial Building
710 Dong Fang Road, Pudong, Shanghai, 200122, China

Telephone: 86-21-58201611
Fax: 86-21-58201621
Email: terasaki@vip.163.com

TERASAKI ELECTRIC (EUROPE) LTD.

80 Beardmore Way, Clydebank Industrial Estate
Clydebank, Glasgow, G81 4HT, Scotland (UK)

Telephone: 44-141-941-1940
Fax: 44-141-952-9246
Email: marketing@terasaki.co.uk
<http://www.terasaki.com/>

TERASAKI ELECTRIC (EUROPE) LTD. FILIALE ITALIA

Via Ambrosoli, 4A-20090 Rodano, Milano, Italy

Telephone: 39-02-92278300
Fax: 39-02-92278320
Email: terasaki@terasaki.it
<http://www.terasaki.it/>

TERASAKI ELECTRIC (EUROPE) LTD. SUCURSAL EN ESPAÑA

Pol. Ind. Coll de la Manyà, C/Cal Ros dels Ocells 5-7,
08403 Granollers, Barcelona, Spain

Telephone: 34-93-879-60-50
Fax: 34-93-870-39-05
Email: terasaki@terasaki.es
<http://www.terasaki.es/>

TERASAKI ELECTRIC (EUROPE) LTD. FILIAL SVERIGE

Box 2082 SE-128 22 Skarpnäck Sweden

Telephone: 46-8-556-282-30
Fax: 46-8-556-282-39
Email: info@terasaki.se
<http://www.terasaki.se/>

TERASAKI CIRCUIT BREAKERS (S) PTE. LTD.

17 Tuas Street Singapore 638454

Telephone: 65-6744-9752
Fax: 65-6748-7592
Email: tecs@pacific.net.sg